



LAS VIRGENES MUNICIPAL WATER DISTRICT
4232 Las Virgenes Road
Calabasas, CA 91302

AGENDA
LVMWD BOARD OF DIRECTORS - SPECIAL MEETING
WEDNESDAY, MAY 13, 2026 – 9:00 AM

PUBLIC PARTICIPATION: The public may join this meeting virtually or attend in person in the Board Room. Teleconference participants will be muted until recognized at the appropriate time by the Board President. To join via teleconference, please use the following Webinar ID:

Webinar ID: <https://lvmwd.zoomgov.com/j/1610876866>

To join by telephone, please dial (669) 900-6833 or (346) 248-7799 and enter Webinar ID:
161 087 6866

For members of the public wishing to address the Board during Public Comment or during a specific agenda item, please press "Raise Hand" if you are joining via computer; or press *9 if you are joining via phone; or inform the Executive Assistant/Clerk of the Board if attending in person.

Members of the public can also access and request to speak at meetings live on-line, with audio and limited video, at www.lvmwd.com/livestream. To ensure distribution of the agenda, please submit comments 24 hours prior to the day of the meeting. Those comments, as well as any comments received during the meeting, will be distributed to the members of the Board of Directors and will be made part of the official public record of the meeting. Contact Nancy Lawrence, Executive Assistance/Clerk of the Board, at (818) 251-2123 or nlawrence@lvmwd.gov with any questions.

ACCESSIBILITY: If requested, the agenda and backup materials will be made available in appropriate alternative formats to persons with a disability, as required by Section 202 of the Americans with Disabilities Act of 1990 (42 U.S.C. Sec. 12132), and the federal rules and regulations adopted in the implementation thereof. Any person who requires a disability-related modification or accommodation, to attend or participate in this meeting, including auxiliary aids or services, may request such reasonable modification or accommodation by contacting the Executive Assistant/Clerk of the Board by telephone at (818) 251-2123 or via email to nlawrence@lvmwd.gov at least 48 hours prior to the meeting.

Members of the public wishing to address the Board of Directors are advised that a statement of Public Comment Protocols is available from the Clerk of the Board. Prior to speaking, each speaker is asked to review these protocols, complete a speakers' card, and hand it to the Clerk of the Board. Speakers will be recognized in the order the cards are received. A live webcast of the meeting will be available at LVMWD.com. Also, a web-based version of the speaker card is available for those who would like to submit written comments electronically or request to make public comment by telephone during the meeting.

The Public Comments agenda item is presented to allow the public to address the Board on matters not on the agenda. The public may also present comments on matters on the agenda; speakers for agenda items will be recognized at the time the item is called up for discussion.

Materials prepared by the District in connection with the subject matter on the agenda are available for public inspection at 4232 Las Virgenes Road, Calabasas, CA 91302. Materials prepared by the District and distributed to the Board during this meeting are available for public inspection at the meeting or as soon thereafter as possible. Materials presented to the Board by the public will be maintained as part of the records of these proceedings and are available upon request to the Clerk of the Board.

PLEDGE OF ALLEGIANCE

1. **CALL TO ORDER AND ROLL CALL**
2. **APPROVAL OF AGENDA**
3. **PUBLIC COMMENTS**

*Members of the public may now address the Board of Directors **ON MATTERS NOT APPEARING ON THE AGENDA**, but within the jurisdiction of the Board. No action shall be taken on any matter not appearing on the agenda unless authorized by Subdivision (b) of Government Code Section 54954.2*

4. **CONSENT CALENDAR**

Matters listed under the Consent Calendar are considered to be routine, non-controversial and normally approved with one motion. If discussion is requested by a

member of the Board on any Consent Calendar item, or if a member of the public wishes to comment on an item, that item will be removed from the Consent Calendar for separate action.

4.A **List of Demands: May 13, 2026 (Pg. 4)**

Receive and file.

4.B **Los Angeles County 2026 Water Resiliency Summit: Board Member (Pg. 97) Attendance**

Authorize Board Member attendance and per diem compensation for the Los Angeles County 2026 Water Resiliency Summit to be held on May 18, 2026.

4.C **Update to the District's Investment Policy (Pg. 102)**

Pass, approve and adopt proposed Resolution No. 2673, adopting a revised Investment Policy pursuant to Section 2-6.502 of the Las Virgenes Municipal Water District Code.

RESOLUTION NO. 2673

A RESOLUTION OF THE BOARD OF DIRECTORS OF LAS VIRGENES MUNICIPAL WATER DISTRICT ADOPTING A REVISED INVESTMENT POLICY

(Reference is hereby made to Resolution No. 2673 on file in the District's Resolution Book and by this reference the same is incorporated herein.)

5. **ILLUSTRATIVE AND/OR VERBAL PRESENTATION AGENDA ITEMS**

5.A **Water Supply Conditions Update (Pg. 176)**

5.B **External Affairs Update**

5.C **Legislative and Regulatory Update**

6. **TREASURER**

7. **ENGINEERING AND FACILITIES**

7.A **Equestrian Tank Rehabilitation Project: Design Award (Pg. 181)**

Accept the proposal from HDR Engineering, Inc., and authorize the General Manager to execute a professional services agreement, in the amount of \$249,504, for design, bidding, and construction support services for the Equestrian Tank Rehabilitation Project.

8. **NON-ACTION ITEMS**

A. *General Manager's Reports*

(a) *General Business*

(b) *Follow-up Items*

B. Directors' Comments and Reports on Outside Meetings

9. **FUTURE AGENDA ITEMS**

10. **CLOSED SESSION**

10.A **Conference with District Legal Counsel - Anticipated Litigation (Government Code Section 54956.9(d)(1)): Lindero Canyon Road/Agoura Road Soil Contamination**

10.B **Claims Filed by Sandro Splendore and Seaview Insurance**

11. **ADJOURNMENT**

Pursuant to Section 202 of the Americans with Disabilities Act of 1990 (42 U.S.C. Sec. 12132), and applicable federal rules and regulations, requests for a disability-related modification or accommodation, including auxiliary aids or services, in order to attend or participate in a meeting, should be made to the Executive Assistant/Clerk of the Board in advance of the meeting to ensure availability of the requested service or accommodation. Notices, agendas, and public documents related to the Board meetings can be made available in appropriate alternative format upon request.

Agenda Item No. 4.A

LAS VIRGENES MUNICIPAL WATER DISTRICT

To: RANDY LEVINE, TREASURER

Payments for Board Meeting of : May 13, 2026

Deputy Treasurer has verified that all checks and wire transfers were issued in conformance with LVMWD Administrative Code Section 2-6.203.

Wells Fargo Bank A/C No. 4806-994448

Check Nos. 114424-114579; ACH/ACI Nos. 1143-1152; 1154-1167; 1170-1184 were issued in the total amount of: **\$ 3,024,734.48**

Payments through direct disbursements as follows:

Direct Disbursement payment number 26209; 26217-26227 **\$ 60,339.24**

Payments through wire transfers as follows:

4/21/2026 Wire #1169 - CA State Treasurer BOE Use-Tax Payment for the month of March 2026 **\$ 21,642.00**

Total Payments \$ 3,106,715.72

(Reference is hereby to these demands on file in the District's Check Register and by this reference the same is incorporated herein and made a part hereof.)

**CHECK/ACH/ACI LISTING FOR BOARD MEETING
5/13/2026**

Company Name	Company No.	Check No. 114424-114457; 1143-1151 04/07/26 Amount	Check No. 1152 04/07/26 Amount	Check No. 114458 04/07/26 Amount	Check No. 114459-114527; 1154-1167 04/14/26 Amount	Check No. 114528-114579; 1170-1184 04/21/26 Amount	Total
Potable Water Operations	101	187,285.11			84,949.73	116,768.44	389,003.28
Recycled Water Operations	102	769.50					769.50
Sanitation Operations	130	17,506.16			5,715.66	783.29	24,005.11
Potable Water Construction	201						-
Water Conservation Construction	203						-
Sanitation Construction	230						-
Potable Water Replacement	301	258,171.33			63,360.88	208,822.88	530,355.09
Recycled Water Replacement	302						-
Sanitation Replacement	330						-
Internal Service	701	27,876.42			359,384.23	227,686.30	614,946.95
JPA Operations	751	51,914.54	9,448.18	988.68	276,076.29	134,248.30	472,675.99
JPA Construction	752						-
JPA Replacement	754	48,959.36			1,136.52	945,943.76	996,039.64
Total Printed		592,482.42	9,448.18	988.68	790,623.31	1,634,252.97	3,027,795.56
Voided Checks/ACH/ACI stopped:							
ACI No. 1095	751	(1,702.22)	-	-	-	-	(1,702.22)
ACI No. 1130	101	(338.03)	-	-	-	-	(338.03)
ACI No. 1141	751	(114.14)	-	-	-	-	(114.14)
ACI No. 1077	751	(906.69)	-	-	-	-	(906.69)
Total Voids		(3,061.08)	-	-	-	-	(3,061.08)
Net Total		589,421.34	9,448.18	988.68	790,623.31	1,634,252.97	3,024,734.48

**DIRECT DISBURSEMENTS LISTING FOR BOARD MEETING
5/13/2026**

Company Name	Company No.	Direct Disb. No. 26209; 26217-26226 04/14/26 Amount	Direct Disb. No. 26227; 04/21/26 Amount	Total
Potable Water Operations	101	2,818.40	4,111.12	6,929.52
Recycled Water Operations	102			-
Sanitation Operations	130			-
Potable Water Construction	201			-
Water Conservation Construction	203			-
Sanitation Construction	230			-
Potable Water Replacement	301			-
Recycled Water Replacement	302			-
Sanitation Replacement	330			-
Internal Service	701	1,126.24	45,440.95	46,567.19
JPA Operations	751	152.25	6,690.28	6,842.53
JPA Construction	752			-
JPA Replacement	754			-
	Total Printed	4,096.89	56,242.35	60,339.24
Voided Direct Disbursements:				
		-	-	-
		-	-	-
	Total Voids	-	-	-
	Totals	4,096.89	56,242.35	60,339.24

**WIRE LISTING FOR BOARD MEETING
5/13/2026**

		Wire No. 1169 04/21/26		
Company Name	Company No.	Amount	Total	
Potable Water Operations	101	-	-	
Recycled Water Operations	102	-	-	
Sanitation Operations	130	-	-	
Potable Water Construction	201	-	-	
Water Conservation Construction	203	-	-	
Sanitation Construction	230	-	-	
Potable Water Replacement	301	-	-	
Recycled Water Replacement	302	-	-	
Sanitation Replacement	330	-	-	
Internal Service	701	-	-	
JPA Operations	751	21,642.00	21,642.00	
JPA Construction	752	-	-	
JPA Replacement	754	-	-	
Total Printed		21,642.00	21,642.00	
Voided Wires:				
		-	-	
		-	-	
Total Voids		-	-	
Totals		21,642.00	21,642.00	

A/P CASH DISBURSEMENTS JOURNAL

CASH ACCOUNT: 999 100100 Cash-General
 CHECK NO CHK DATE TYPE VENDOR NAME

CHECK NO	CHK DATE	TYPE	VENDOR NAME	INVOICE	INV DATE	PO	CHECK RUN	NET
1143	04/07/2026	EFT	7421 HAMNER, JEWELL AND ASSOCIATES	205466	03/16/2026		040726	2,775.00
					EASMNT ACQUISTN SVCS CALAMIGOS FEBRUARY 2026			
				2,775.00 101700 541500	Outside Services			
					CHECK		1143 TOTAL:	2,775.00
1144	04/07/2026	EFT	20779 SAND MATERIALS & AGGREGATE SALES, 95076		03/17/2026		040726	839.51
				839.51 101700 551000	26.31 TONS FILL SAND Supplies/Material			
					CHECK		1144 TOTAL:	839.51
1145	04/07/2026	EFT	3035 VWR SCIENTIFIC	8821206111	03/16/2026		040726	927.55
				927.55 701341 551000	HEXANE, BEAKER CUPS Supplies/Material			
			VWR SCIENTIFIC	8821206112	03/16/2026		040726	26.80
				26.80 701341 551000	VIOLET DYE Supplies/Material			
			VWR SCIENTIFIC	8821210999	03/16/2026		040726	1,180.33
				1,180.33 701341 551000	HOT/STIR PLATES, TRYPTIC SOY Supplies/Material			
			VWR SCIENTIFIC	8821213689	03/16/2026		040726	97.78
				97.78 701341 551000	SODIUM HYDROXIDE Supplies/Material			
			VWR SCIENTIFIC	8821215754	03/17/2026		040726	166.87
				166.87 701341 551000	EDTA Supplies/Material			
			VWR SCIENTIFIC	8821268021	03/23/2026		040726	80.84
				80.84 701341 551000	SODIUM SULFITE Supplies/Material			
					CHECK		1145 TOTAL:	2,480.17
1146	04/07/2026	PRTD	2317 STRICKBINE PUBLISHING, INC	2026-179646	03/20/2026		040726	576.00
				576.00 751840 660400	1/4 DISPLAY AD - FREE COMPOST 3/20/26 Public Education Programs			
					CHECK		1146 TOTAL:	576.00
1147	04/07/2026	PRTD	2814 MCMASTER-CARR SUPPLY CO	61867185	03/20/2026		040726	121.09
				121.09 751820 551000	ELECTRICAL SUPPLIES Supplies/Material			

A/P CASH DISBURSEMENTS JOURNAL

CASH ACCOUNT: 999 100100 Cash-General
 CHECK NO CHK DATE TYPE VENDOR NAME

CHECK NO	CHK DATE	TYPE	VENDOR NAME	INVOICE	INV DATE	PO	CHECK RUN	NET
			MCMaster-CARR SUPPLY CO	61624717	03/17/2026		040726	163.00
Invoice: 61624717				163.00 751810 551000	ELECTRICAL SUPPLIES			
					Supplies/Material			
			MCMaster-CARR SUPPLY CO	61784228	03/19/2026		040726	251.88
Invoice: 61784228				251.88 101600 541000	LAB SUPPLIES			
					Supplies/Material			
			MCMaster-CARR SUPPLY CO	61850655	03/20/2026		040726	122.39
Invoice: 61850655				122.39 101600 541000	ROUTING EYE BOLT & HEX HEAD SCREW			
					Supplies/Material			
						CHECK	1147 TOTAL:	658.36
1148 04/07/2026 PRTD			7770 AUTOMATIONDIRECT.COM	18930651	02/11/2026		040726	1,281.88
Invoice: 18930651				1,281.88 751820 551000	ELECTRICAL SUPPLIES			
					Supplies/Material			
			AUTOMATIONDIRECT.COM	18903641	02/04/2026		040726	192.61
Invoice: 18903641				192.61 751810 551000	ELECTRICAL SUPPLIES			
					Supplies/Material			
			AUTOMATIONDIRECT.COM	18951960	02/18/2026		040726	227.73
Invoice: 18951960				227.73 751820 551000	ELECTRICAL SUPPLIES			
					Supplies/Material			
						CHECK	1148 TOTAL:	1,702.22
1149 04/07/2026 PRTD			7770 AUTOMATIONDIRECT.COM	18983743	03/02/2026		040726	338.03
Invoice: 18983743				338.03 101600 551000	ELECTRICAL SUPPLIES			
					Supplies/Material			
			AUTOMATIONDIRECT.COM	19016150	03/11/2026		040726	114.14
Invoice: 19016150				114.14 751820 551000	ENCLOSURE WITH BACK PANEL			
					Supplies/Material			
			AUTOMATIONDIRECT.COM	19009409	03/09/2026		040726	390.71
Invoice: 19009409				390.71 751820 551000	ENCLOSURE WITH BACK PANELS			
					Supplies/Material			
						CHECK	1149 TOTAL:	842.88
1150 04/07/2026 PRTD			18914 WECK LABORATORIES, INC.	W5L1858	01/28/2026		040726	19,303.59
Invoice: W5L1858				5,679.81 751750 571520	LAB SAMPLING			
				6,875.53 751750 571520	Other Laboratory Serv			
				122.50 751750 571520	Other Laboratory Serv			
				1,533.75 751750 571520	Other Laboratory Serv			
				122.50 751750 571520	Other Laboratory Serv			

A/P CASH DISBURSEMENTS JOURNAL

CASH ACCOUNT: 999 100100 Cash-General
 CHECK NO CHK DATE TYPE VENDOR NAME

CHECK NO	CHK DATE	TYPE	VENDOR NAME	INVOICE	INV DATE	PO	CHECK RUN	NET
				INVOICE DTL DESC				
				2,799.25 751750 571520				
				319.00 751750 571520				
				122.50 751750 571520				
				1,533.75 751750 571520				
				195.00 751750 571520				
							CHECK 1150 TOTAL:	19,303.59
1151	04/07/2026	PRTD	30619 LLOYD'S PLUMBING, INC.	202634630	01/05/2026		040726	906.69
			Invoice: 202634630					
				906.69 751820 551500			CLEAR DRAIN LINE 1/5/26 Outside Services	
							CHECK 1151 TOTAL:	906.69
114424	04/07/2026	PRTD	30729 AMAZON CAPITAL SERVICES, INC.	1333-9LGX-TCYG	03/18/2026		040726	193.80
			Invoice: 1333-9LGX-TCYG					
				193.80 701230 660200			3 INCH PLANT NURSERY POTS School Education Programs	
			Invoice: 1K3M-QJY3-D9VH					
				76.81 701525 551000			AMAZON CAPITAL SERVICES, INC. 1K3M-QJY3-D9VH 03/24/2026 LIFT CAR RAMPS Supplies/Material	76.81
			Invoice: 1NVK-R3CP-H3JN					
				168.56 101700 551000			AMAZON CAPITAL SERVICES, INC. 1NVK-R3CP-H3JN 03/19/2026 NICKEL ANTI-SEIZE Supplies/Material	168.56
			Invoice: 1P7C-PGV9-6JM7					
				109.72 701526 572500			AMAZON CAPITAL SERVICES, INC. 1P7C-PGV9-6JM7 03/24/2026 ROUND CABLE STRIPPER Genl Supplies/Small Tools	109.72
			Invoice: 1PMH-DNCX-P9MD					
				74.22 751820 551000			AMAZON CAPITAL SERVICES, INC. 1PMH-DNCX-P9MD 03/19/2026 ORANGE INDICATING SILICA GEL DESSICANT Supplies/Material	74.22
			Invoice: 1DDN-GP9T-9H6T					
				481.74 701525 551000			AMAZON CAPITAL SERVICES, INC. 1DDN-GP9T-9H6T 03/20/2026 ROOFTOP STROBE LIGHT BAR Supplies/Material	481.74
			Invoice: 11G4-G9FG-QHPX					
				43.89 701322 572500			AMAZON CAPITAL SERVICES, INC. 11G4-G9FG-QHPX 03/23/2026 EARPODS & CAR CHARGER Genl Supplies/Small Tools	43.89
			Invoice: 13JC-FK7D-WHPH					
				32.89 701526 572500			AMAZON CAPITAL SERVICES, INC. 13JC-FK7D-WHPH 03/17/2026 SCREWDRIVER SET Genl Supplies/Small Tools	32.89
			Invoice: 134P-6HWT-FGDC					
				1,380.48 701526 572500			AMAZON CAPITAL SERVICES, INC. 134P-6HWT-FGDC 03/19/2026 FLUKE 789 PROCESSMETER Genl Supplies/Small Tools	1,380.48

A/P CASH DISBURSEMENTS JOURNAL

CASH ACCOUNT: 999 100100 Cash-General
 CHECK NO CHK DATE TYPE VENDOR NAME

CHECK NO	CHK DATE	TYPE	VENDOR NAME	INVOICE	INV DATE	PO	CHECK RUN	NET
CHECK 114430 TOTAL:								20.00
114431	04/07/2026	PRTD	30915 DK FLEET INC.	7731	01/05/2026		040726	251.48
Invoice: 7731				251.48	701525	551500	RPLC LEAKING TRAILER BRAKE AIR LINE VEH#163 Outside Services	
Invoice: 7920				814.81	701525	551500	CRANE INSTL VEH#963 Outside Services	814.81
Invoice: 8393				1,550.45	701525	551500	RPLC FAULTY SRTR VACCUM TRLR VEH#953 Outside Services	1,550.45
CHECK 114431 TOTAL:								2,616.74
114432	04/07/2026	PRTD	2655 FERGUSON WATERWORKS #1089	0067017	03/16/2026	2260107	040726	27,347.73
Invoice: 0067017				27,347.73	301440	900000	PAUL REVERE PRS REHAB SUPPLIES Capital Asset Expenses	
Invoice: 0066949-2				4,232.71	301440	900000	PAUL REVERE PRS REHAB SUPPLIES Capital Asset Expenses	4,232.71
CHECK 114432 TOTAL:								31,580.44
114433	04/07/2026	PRTD	2611 LA DWP	0176980000/031826	03/18/2026		040726	51.75
Invoice: 0176980000/031826				51.75	101700	540510	RECTIFIER 2/18-3/18/26 Energy	
Invoice: 8756980000/031926				20,024.50	101106	540510	TWIN LAKES P/S 1/17-3/19/26 Energy	20,024.50
Invoice: 5038501000/032026				46.00	101700	540510	RECTIFIER 2/19-3/20/26 Energy	46.00
CHECK 114433 TOTAL:								20,122.25
114434	04/07/2026	PRTD	31084 LEE & RO, INC	1287-02/03	03/18/2026		040726	29,450.99
Invoice: 1287-02/03				29,450.99	754440	900000	RW P/S WEST REHAB FEBRUARY 2026 Capital Asset Expenses	
Invoice: 1287-01/03				18,822.37	754440	900000	TAPIA EFFLUENT P/S REHAB FEBRUARY 2026 Capital Asset Expenses	18,822.37

A/P CASH DISBURSEMENTS JOURNAL

CASH ACCOUNT: 999 100100 Cash-General
 CHECK NO CHK DATE TYPE VENDOR NAME

CHECK NO	CHK DATE	TYPE	VENDOR NAME	INVOICE	INV DATE	PO	CHECK RUN	NET
INVOICE DTL DESC								
							CHECK 114434 TOTAL:	48,273.36
114435	04/07/2026	PRTD	8484 LINDE GAS AND EQUIPMENT INC.	55622574	03/22/2026		040726	54.02
			Invoice: 55622574				CYLINDER RENTAL 2/20-3/20/26	
				54.02 101100 541000			Supplies/Material	
							CHECK 114435 TOTAL:	54.02
114436	04/07/2026	PRTD	21463 LOREN BRUGGER WELDING	6117	03/19/2026		040726	6,740.00
			Invoice: 6117				WELDING SVCS 3/19/26	
				6,740.00 101700 551500			Outside Services	
							CHECK 114436 TOTAL:	6,740.00
114437	04/07/2026	PRTD	30556 MALLORY SAFETY & SUPPLY LLC	6380402	03/19/2026		040726	262.44
			Invoice: 6380402				NH3 MODULE FOR DETECTOR	
				262.44 101600 551000			Supplies/Material	
							CHECK 114437 TOTAL:	262.44
114438	04/07/2026	PRTD	19155 MCR TECHNOLOGIES, INC.	44558	03/24/2026		040726	4,987.04
			Invoice: 44558				6" FLOW METER THREE SPRINGS P/S	
				4,987.04 101100 551000			Supplies/Material	
							CHECK 114438 TOTAL:	4,987.04
114439	04/07/2026	PRTD	2835 MODERN TOOL CO	76079	03/20/2026		040726	1,172.32
			Invoice: 76079				STAINLESS STEEL SHAFT AND FLANGE	
				1,172.32 751810 551500			Outside Services	
							CHECK 114439 TOTAL:	1,172.32
114440	04/07/2026	PRTD	30857 DOCUMENT SYSTEMS	IN5295461	03/23/2026		040726	16.93
			Invoice: IN5295461				CANON OVRG 2/24-3/23/26	
				16.93 701420 620500			Equip Rental	
			DOCUMENT SYSTEMS	IN5295375	03/23/2026		040726	37.42
			Invoice: IN5295375				CANON OVRG 3/7-3/23/26	
				37.42 701420 620500			Equip Rental	
							CHECK 114440 TOTAL:	54.35
114441	04/07/2026	PRTD	2302 ODP BUSINESS SOLUTIONS LLC	461973767001	03/18/2026		040726	140.81
			Invoice: 461973767001				BINDERS	
				140.81 701510 620000			Forms, Supplies And Postage	

A/P CASH DISBURSEMENTS JOURNAL

CASH ACCOUNT: 999 100100 Cash-General
 CHECK NO CHK DATE TYPE VENDOR NAME

CHECK NO	CHK DATE	TYPE	VENDOR NAME	INVOICE	INV DATE	PO	CHECK RUN	NET
CHECK 114441 TOTAL: 140.81								
114442	04/07/2026	PRTD	18874 PACIFIC HYDROTECH CORPORATION	10655/PMT #14	03/11/2026		040726	81,338.90
			Invoice: 10655/PMT #14	81,338.90 301440 900000	CORNELL P/S IMPROVEMENTS FEBRUARY 2026 Capital Asset Expenses			
CHECK 114442 TOTAL: 81,338.90								
114443	04/07/2026	PRTD	17326 RINCON CONSULTANTS, INC.	73185	03/20/2026		040726	686.00
			Invoice: 73185	686.00 754440 900000	TAPIA OUTFALL 11/1/25-2/28/26 Capital Asset Expenses			
CHECK 114443 TOTAL: 686.00								
114444	04/07/2026	PRTD	20124 RON'S PORTABLE WELDING	7046	03/24/2026		040726	480.00
			Invoice: 7046	480.00 101700 551500	WELDING SVCS 3/24/26 Outside Services			
			Invoice: 7045	1,050.00 101700 551500	RON'S PORTABLE WELDING 7045 WELDING SVCS 3/23/26 Outside Services			1,050.00
			Invoice: 7044	1,860.00 101700 551500	RON'S PORTABLE WELDING 7044 WELDING SVCS 3/19/26 Outside Services			1,860.00
CHECK 114444 TOTAL: 3,390.00								
114445	04/07/2026	PRTD	4586 ROYAL INDUSTRIAL SOLUTIONS	9009-1067251	03/11/2026		040726	11,876.54
			Invoice: 9009-1067251	11,876.54 301440 900000	RPLCMNT PLCS FOR WLK Capital Asset Expenses			
			Invoice: 9009-1067637	3,380.30 751810 551000	24W BOLLARD LIGHT Supplies/Material			3,380.30
			Invoice: 9009-1067576	419.49 751810 551000	12 BIT PLC CARDS AI/AO Supplies/Material			419.49
			Invoice: 9009-1067516	383.82 751810 551000	PLC CARD Supplies/Material			383.82
			Invoice: 9009-1067515	383.82 751810 551000	PLC CARD Supplies/Material			383.82

A/P CASH DISBURSEMENTS JOURNAL

CASH ACCOUNT: 999 100100 Cash-General
 CHECK NO CHK DATE TYPE VENDOR NAME

CHECK NO	CHK DATE	TYPE	VENDOR NAME	INVOICE	INV DATE	PO	CHECK RUN	NET
INVOICE DTL DESC								
Invoice: 9009-1067342			ROYAL INDUSTRIAL SOLUTIONS	9009-1067342	03/24/2026		040726	4,295.48
			4,295.48 301440 900000	AB 5069	CONTROLLER			
					Capital Asset Expenses			
				CHECK	114445 TOTAL:			20,739.45
114446	04/07/2026	PRTD	30020 SOUTHERN CA EDISON	11884/032326	03/23/2026		040726	106,200.85
Invoice: 11884/032326					DECEMBER-MARCH 2026	NET USAGE		
			55.44 101100	540510	Energy			
			7,707.92 101101	540510	Energy			
			4,214.76 101102	540510	Energy			
			50,328.30 101103	540510	Energy			
			5,190.61 101104	540510	Energy			
			613.88 101105	540510	Energy			
			1,168.53 101107	540510	Energy			
			6,223.03 101108	540510	Energy			
			308.52 101109	540510	Energy			
			1,879.43 101110	540510	Energy			
			591.72 101112	540510	Energy			
			7,668.94 101113	540510	Energy			
			1,133.24 101114	540510	Energy			
			1,047.38 101115	540510	Energy			
			1,441.58 101116	540510	Energy			
			1,170.22 101117	540510	Energy			
			4,341.10 101118	540510	Energy			
			666.09 101119	540510	Energy			
			7,357.73 101120	540510	Energy			
			645.18 101121	540510	Energy			
			1,018.74 101122	540510	Energy			
			1,702.12 101123	540510	Energy			
			851.06 101124	540510	Energy			
			138.76 101202	540510	Energy			
			193.31 101204	540510	Energy			
			20.99 101209	540510	Energy			
			18.54 101211	540510	Energy			
			25.60 101212	540510	Energy			
			30.37 101220	540510	Energy			
			10.59 101221	540510	Energy			
			27.65 101222	540510	Energy			
			13,457.86 101600	540510	Energy			
			29.96 101700	540510	Energy			
			769.50 102100	540510	Energy			
			13,781.16 130100	540510	Energy			
			13,057.76 701001	540510	Energy			
			615.77 701002	540510	Energy			
			39.62 701526	540510	Energy			
			166.18 751125	540510	Energy			
			21,724.08 751126	540510	Energy			
			157.66 751224	540510	Energy			
			22.59 751810	678900	005 Discharge			

A/P CASH DISBURSEMENTS JOURNAL

CASH ACCOUNT: 999 100100 Cash-General
 CHECK NO CHK DATE TYPE VENDOR NAME

CHECK NO	CHK DATE	TYPE	VENDOR NAME	INVOICE	INV DATE	PO	CHECK RUN	NET
					INVOICE DTL DESC			
				88,726.92 751810 540510				
				108.58 751810 678800				
				17.42 751820 540510				
				11,156.21 751830 540510				
				-129,028.97 751101 540511				
				-18,196.39 751127 540511				
				-18,196.39 751128 540511				
							CHECK 114446 TOTAL:	106,200.85
114447	04/07/2026	PRTD	2957 SOUTHERN CALIFORNIA EDISON (M-BIL 75690/022626	02/26/2026		040726		2,253.91
			Invoice: 75690/022626	BLDG 1 HM-PWP 1/23-2/23/26 8,934 KH				
			2,253.91 751750 540510	Energy				
			Invoice: 90504/022626	SOUTHERN CALIFORNIA EDISON (M-BIL 90504/022626	02/26/2026	040726		1,158.92
				N. CYN P/S 12/31/25-1/29/26 2,226 KH				
			1,158.92 751810 678800	District Sprayfield				
			Invoice: 77683/022626	SOUTHERN CALIFORNIA EDISON (M-BIL 77683/022626	02/26/2026	040726		1,002.54
				BLDG 1 EV-PWP 1/23-2/23/26 3,254 KH				
			1,002.54 751750 540510	Energy				
			Invoice: 57161/032626	SOUTHERN CALIFORNIA EDISON (M-BIL 57161/032626	03/26/2026	040726		10,014.39
				RLV COMPOST PLNT 12/20/24-2/23/26 BILLING CRCTN				
			10,014.39 751820 540510	Energy				
			Invoice: 57161/032626A	SOUTHERN CALIFORNIA EDISON (M-BIL 57161/032626A	03/26/2026	040726		45,472.09
				RLV COMPOST PLNT 2/24-3/24/26 233,054 KH				
			45,472.09 751820 540510	Energy				
							CHECK 114447 TOTAL:	59,901.85
114448	04/07/2026	PRTD	2958 SOUTHERN CALIFORNIA GAS CO (M-BIL 06871284003/032626	03/26/2026		040726		15.29
			Invoice: 06871284003/032626	CONDUIT 2/20-3/23/26 0 THERMS				
			15.29 101101 540530	Gas				
							CHECK 114448 TOTAL:	15.29
114449	04/07/2026	PRTD	11430 SPIESS CONSTRUCTION COMPANY INC. 225011	02/04/2026		040726		115,263.97
			Invoice: 225011	CALABASAS TANK REHAB JANUARY 2026				
			115,263.97 301440 900000	Capital Asset Expenses				
							CHECK 114449 TOTAL:	115,263.97
114450	04/07/2026	PRTD	31133 SWIFTCOMPLY US OPCO, INC INV000402	03/26/2026		040726		4,800.00
			Invoice: INV000402	BACKFLOW PROFESSIONAL SERVICES				
			4,800.00 701420 621500	System Support and Maintenance				

A/P CASH DISBURSEMENTS JOURNAL

CASH ACCOUNT: 999 100100 Cash-General
 CHECK NO CHK DATE TYPE VENDOR NAME

CHECK NO	CHK DATE	TYPE	VENDOR NAME	INVOICE	INV DATE	PO	CHECK RUN	NET
CHECK 114450 TOTAL:								4,800.00
114451	04/07/2026	PRTD	31043	TOTAL ACCESS ELEVATOR LLC	INV-07346-T3J0	03/01/2026	040726	290.00
Invoice: INV-07346-T3J0				145.00 701001 551500	MARCH 2026 ELEVATOR SRV			
				145.00 701002 551500	Outside Services			
CHECK 114451 TOTAL:								290.00
114452	04/07/2026	PRTD	2325	UNITED RENTALS, INC	259050349-001	03/23/2026	040726	619.00
Invoice: 259050349-001				619.00 751810 551500	REPLACED FAILED SOLENOID - RANCHO GOLFCART			
					Outside Services			
Invoice: 259266699-001			UNITED RENTALS, INC	259266699-001	03/23/2026	040726	390.00	
				390.00 701525 551500	PREVENTATIVE MAINT. HQ SCISSOR LIFT #110			
					Outside Services			
Invoice: 259266856-001			UNITED RENTALS, INC	259266856-001	03/23/2026	040726	470.00	
				470.00 751820 551500	PREVENTATIVE MAINT. RANCHO FORKLIFT #723			
					Outside Services			
Invoice: 259267901-001			UNITED RENTALS, INC	259267901-001	03/23/2026	040726	359.70	
				359.70 751820 551500	PREVENTATIVE MAINT. RANCHO GOLFCART #712			
					Outside Services			
Invoice: 259267050-001			UNITED RENTALS, INC	259267050-001	03/23/2026	040726	466.00	
				466.00 701525 551500	PREVENTATIVE MAINT. HQ KUBOTA #102			
					Outside Services			
Invoice: 259267150-001			UNITED RENTALS, INC	259267150-001	03/23/2026	040726	790.37	
				790.37 751820 551500	RANCHO BOBCAT #967 - SVC, OIL/AIR FILTER CHANGE			
					Outside Services			
Invoice: 259267313-001			UNITED RENTALS, INC	259267313-001	03/23/2026	040726	447.00	
				447.00 751820 551500	PREVENTATIVE MAINT. RANCHO MAN LIFT #701			
					Outside Services			
Invoice: 259267782-001			UNITED RENTALS, INC	259267782-001	03/23/2026	040726	358.00	
				358.00 751810 551500	PREVENTATIVE MAINT. TAPIA GOFL CART #304			
					Outside Services			
Invoice: 259267834-001			UNITED RENTALS, INC	259267834-001	03/23/2026	040726	470.00	
				470.00 751810 551500	PREVENTATIVE MAINT. TAPIA FORKLIFT #305			
					Outside Services			
Invoice: 259267859-001			UNITED RENTALS, INC	259267859-001	03/23/2026	040726	358.00	
				358.00 751810 551500	PREVENTATIVE MAINT. TAPIA GOFL CART #306			
					Outside Services			

A/P CASH DISBURSEMENTS JOURNAL

CASH ACCOUNT: 999 100100 Cash-General
 CHECK NO CHK DATE TYPE VENDOR NAME

CHECK NO	CHK DATE	TYPE	VENDOR NAME	INVOICE	INV DATE	PO	CHECK RUN	NET
INVOICE DTL DESC								
							CHECK 114452 TOTAL:	4,728.07
114453	04/07/2026	PRTD	2780 VALLEY NEWS GROUP	3-19	03/20/2026		040726	250.00
	Invoice: 3-19			250.00 751840 660400	DISPLAY AD- FREE COMPOST 3/19/26 Public Education Programs			
							CHECK 114453 TOTAL:	250.00
114454	04/07/2026	PRTD	21509 VEGA AMERICAS, INC.	678261	03/16/2026		040726	2,178.27
	Invoice: 678261			2,178.27 101600 551000	LEVEL SENSOR FOR NHM TANK WLK Supplies/Material			
	Invoice: 678905		VEGA AMERICAS, INC.	678905	03/19/2026		040726	2,023.45
				2,023.45 751820 551000	RADAR LEVEL TRANSMITTER Supplies/Material			
							CHECK 114454 TOTAL:	4,201.72
114455	04/07/2026	PRTD	2701 GRAINGER	9835305195	03/09/2026		040726	117.87
	Invoice: 9835305195			117.87 751820 551000	URINAL AUGER Supplies/Material			
							CHECK 114455 TOTAL:	117.87
114456	04/07/2026	PRTD	3025 WATER & SANITATION SRV./VENTURA C	3166911	03/25/2026		040726	23,761.28
	Invoice: 3166911			23,761.28 101001 510500	PURCHASED WATER 2/17-3/17/26 Purch Water-Ventura County			
							CHECK 114456 TOTAL:	23,761.28
114457	04/07/2026	PRTD	31122 ZT CONSULTING GROUP, INC.	2602-563	03/08/2026		040726	3,768.00
	Invoice: 2602-563			3,768.00 301440 900000	MCCOY TANK COATING & WLDNG INSPCTN FEBRUARY 2026 Capital Asset Expenses			
	Invoice: 2601-563		ZT CONSULTING GROUP, INC.	2601-563	02/12/2026		040726	10,048.00
				10,048.00 301440 900000	MCCOY TANK COATING & WLDNG INSPCTN JANUARY 2026 Capital Asset Expenses			
							CHECK 114457 TOTAL:	13,816.00

A/P CASH DISBURSEMENTS JOURNAL

NUMBER OF CHECKS 43 *** CASH ACCOUNT TOTAL *** 592,482.42

	COUNT	AMOUNT
TOTAL PRINTED CHECKS	40	586,387.74
TOTAL EFT'S	3	6,094.68

*** GRAND TOTAL *** 592,482.42

A/P CASH DISBURSEMENTS JOURNAL

JOURNAL ENTRIES TO BE CREATED

CLERK: 3296tchau

YEAR PER	JNL	SRC ACCOUNT	JNL DATE	JNL DESC	REF 1	REF 2	REF 3	ACCOUNT DESC LINE DESC	T OB	DEBIT	CREDIT
2026	10		39								
APP	101-200000		04/07/2026	040726	042726			Accounts Payable		187,285.11	
								AP CASH DISBURSEMENTS JOURNAL			
APP	999-100100		04/07/2026	040726	042726			Cash-General			592,482.42
								AP CASH DISBURSEMENTS JOURNAL			
APP	701-200000		04/07/2026	040726	042726			Accounts Payable		27,876.42	
								AP CASH DISBURSEMENTS JOURNAL			
APP	751-200000		04/07/2026	040726	042726			Accounts Payable		51,914.54	
								AP CASH DISBURSEMENTS JOURNAL			
APP	130-200000		04/07/2026	040726	042726			Accounts Payable		17,506.16	
								AP CASH DISBURSEMENTS JOURNAL			
APP	301-200000		04/07/2026	040726	042726			Accounts Payable		258,171.33	
								AP CASH DISBURSEMENTS JOURNAL			
APP	754-200000		04/07/2026	040726	042726			Accounts Payable		48,959.36	
								AP CASH DISBURSEMENTS JOURNAL			
APP	102-200000		04/07/2026	040726	042726			Accounts Payable		769.50	
								AP CASH DISBURSEMENTS JOURNAL			
GENERAL LEDGER TOTAL										592,482.42	592,482.42
APP	999-201010		04/07/2026	040726	042726			Due to/Due Frm Potable Wtr Ops		187,285.11	
APP	101-100100		04/07/2026	040726	042726			Cash-General			187,285.11
APP	999-207010		04/07/2026	040726	042726			Due to/Due FromInternal Svs		27,876.42	
APP	701-100100		04/07/2026	040726	042726			Cash-General			27,876.42
APP	999-207510		04/07/2026	040726	042726			Due to/Due FromJPA Operations		51,914.54	
APP	751-100100		04/07/2026	040726	042726			Cash-General			51,914.54
APP	999-201300		04/07/2026	040726	042726			Due to/Due FrmSanitation Ops		17,506.16	
APP	130-100100		04/07/2026	040726	042726			Cash-General			17,506.16
APP	999-203010		04/07/2026	040726	042726			Due to/Due FrmPotable Wtr Repl		258,171.33	
APP	301-100100		04/07/2026	040726	042726			Cash-General			258,171.33
APP	999-207540		04/07/2026	040726	042726			Due to/Due FromJPA Replacement		48,959.36	
APP	754-100100		04/07/2026	040726	042726			Cash-General			48,959.36
APP	999-201020		04/07/2026	040726	042726			Due to/Due Frm Recl Wtr Ops		769.50	
APP	102-100100							Cash-General			769.50

A/P CASH DISBURSEMENTS JOURNAL
 JOURNAL ENTRIES TO BE CREATED

YEAR PER	JNL					ACCOUNT DESC	T	OB	DEBIT	CREDIT
SRC ACCOUNT	EFF DATE	JNL DESC	REF 1	REF 2	REF 3	LINE DESC				
	04/07/2026	040726	042726							
						SYSTEM GENERATED ENTRIES TOTAL		592,482.42	592,482.42	
						JOURNAL 2026/10/39 TOTAL		1,184,964.84	1,184,964.84	

A/P CASH DISBURSEMENTS JOURNAL
 JOURNAL ENTRIES TO BE CREATED

FUND ACCOUNT	YEAR PER	JNL	EFF DATE	ACCOUNT DESCRIPTION	DEBIT	CREDIT
101 Potable Water Operations 101-100100 101-200000	2026 10	39	04/07/2026	Cash-General		187,285.11
				Accounts Payable	187,285.11	
				FUND TOTAL	187,285.11	187,285.11
102 Recycled Water Operations 102-100100 102-200000	2026 10	39	04/07/2026	Cash-General		769.50
				Accounts Payable	769.50	
				FUND TOTAL	769.50	769.50
130 Sanitation Operations 130-100100 130-200000	2026 10	39	04/07/2026	Cash-General		17,506.16
				Accounts Payable	17,506.16	
				FUND TOTAL	17,506.16	17,506.16
301 Potable Wtr Replacement Fund 301-100100 301-200000	2026 10	39	04/07/2026	Cash-General		258,171.33
				Accounts Payable	258,171.33	
				FUND TOTAL	258,171.33	258,171.33
701 Internal Service Fund 701-100100 701-200000	2026 10	39	04/07/2026	Cash-General		27,876.42
				Accounts Payable	27,876.42	
				FUND TOTAL	27,876.42	27,876.42
751 JPA Operations 751-100100 751-200000	2026 10	39	04/07/2026	Cash-General		51,914.54
				Accounts Payable	51,914.54	
				FUND TOTAL	51,914.54	51,914.54
754 JPA Replacement 754-100100 754-200000	2026 10	39	04/07/2026	Cash-General		48,959.36
				Accounts Payable	48,959.36	
				FUND TOTAL	48,959.36	48,959.36
999 Pooled Cash 999-100100 999-201010 999-201020 999-201300 999-203010 999-207010	2026 10	39	04/07/2026	Cash-General		592,482.42
				Due to/Due Frm Potable Wtr Ops	187,285.11	
				Due to/Due Frm Recl Wtr Ops	769.50	
				Due to/Due Frm Sanitation Ops	17,506.16	
				Due to/Due Frm Potable Wtr Repl	258,171.33	
				Due to/Due From Internal Svs	27,876.42	

A/P CASH DISBURSEMENTS JOURNAL

JOURNAL ENTRIES TO BE CREATED

FUND	YEAR PER	JNL	EFF DATE	ACCOUNT DESCRIPTION	DEBIT	CREDIT
999-207510				Due to/Due FromJPA Operations	51,914.54	
999-207540				Due to/Due FromJPA Replacement	48,959.36	
				FUND TOTAL	592,482.42	592,482.42

A/P CASH DISBURSEMENTS JOURNAL
 JOURNAL ENTRIES TO BE CREATED

FUND		DUE TO	DUE FR
101	Potable Water Operations		187,285.11
102	Recycled Water Operations		769.50
130	Sanitation Operations		17,506.16
301	Potable Wtr Replacement Fund		258,171.33
701	Internal Service Fund		27,876.42
751	JPA Operations		51,914.54
754	JPA Replacement		48,959.36
999	Pooled Cash		
		592,482.42	
	TOTAL	592,482.42	592,482.42

** END OF REPORT - Generated by Thieu Chau **

A/P CASH DISBURSEMENTS JOURNAL

JOURNAL ENTRIES TO BE CREATED

CLERK: 3296tchau

YEAR PER	JNL	SRC ACCOUNT	EFF DATE	JNL DESC	REF 1	REF 2	REF 3	ACCOUNT DESC LINE DESC	T OB	DEBIT	CREDIT
2026 10	40	APP 751-200000	04/07/2026	033126	033126			Accounts Payable		9,448.18	
		APP 999-100100	04/07/2026	033126	033126			AP CASH DISBURSEMENTS JOURNAL			9,448.18
								Cash-General			
								AP CASH DISBURSEMENTS JOURNAL			
								GENERAL LEDGER TOTAL		9,448.18	9,448.18
APP 999-207510								Due to/Due FromJPA Operations		9,448.18	
		APP 751-100100	04/07/2026	033126	033126			Cash-General			9,448.18
								SYSTEM GENERATED ENTRIES TOTAL		9,448.18	9,448.18
								JOURNAL 2026/10/40	TOTAL	18,896.36	18,896.36

A/P CASH DISBURSEMENTS JOURNAL

JOURNAL ENTRIES TO BE CREATED

FUND	ACCOUNT	YEAR	PER	JNL	EFF DATE	ACCOUNT DESCRIPTION	DEBIT	CREDIT
751	JPA Operations	2026	10	40	04/07/2026			
	751-100100					Cash-General		9,448.18
	751-200000					Accounts Payable	9,448.18	
						FUND TOTAL	9,448.18	9,448.18
999	Pooled Cash	2026	10	40	04/07/2026			
	999-100100					Cash-General		9,448.18
	999-207510					Due to/Due From JPA Operations	9,448.18	
						FUND TOTAL	9,448.18	9,448.18

A/P CASH DISBURSEMENTS JOURNAL
JOURNAL ENTRIES TO BE CREATED

FUND		DUE TO	DUE FR
751	JPA Operations		9,448.18
999	Pooled Cash	9,448.18	
TOTAL		9,448.18	9,448.18

** END OF REPORT - Generated by Thieu Chau **

A/P CASH DISBURSEMENTS JOURNAL

CASH ACCOUNT: 999 100100 Cash-General
 CHECK NO CHK DATE TYPE VENDOR NAME

CHECK NO	CHK DATE	TYPE	VENDOR NAME	INVOICE	INV DATE	PO	CHECK RUN	NET
114458	04/07/2026	PRTD	30543 JEREMY WOLF	040726	04/01/2026		040726A	988.68
Invoice: 040726								
				988.68	751840	660600	REIMB. CASHIERS CHECK FOR SHERIFFS AT PWP EVENT Community Group Outreach	
							CHECK 114458 TOTAL:	988.68
NUMBER OF CHECKS					1	*** CASH ACCOUNT TOTAL ***		988.68
				TOTAL PRINTED CHECKS	COUNT	AMOUNT		
					1	988.68		
							*** GRAND TOTAL ***	988.68

A/P CASH DISBURSEMENTS JOURNAL

JOURNAL ENTRIES TO BE CREATED

CLERK: 3296tchau

YEAR PER	JNL	SRC ACCOUNT	JNL DESC	REF 1	REF 2	REF 3	ACCOUNT DESC LINE DESC	T OB	DEBIT	CREDIT
2026 10	44	APP 751-200000					Accounts Payable		988.68	
		04/07/2026	040726A	040726			AP CASH DISBURSEMENTS JOURNAL			
		APP 999-100100					Cash-General			988.68
		04/07/2026	040726A	040726			AP CASH DISBURSEMENTS JOURNAL			
							GENERAL LEDGER TOTAL		988.68	988.68
APP 999-207510		04/07/2026	040726A	040726			Due to/Due FromJPA Operations		988.68	
APP 751-100100		04/07/2026	040726A	040726			Cash-General			988.68
							SYSTEM GENERATED ENTRIES TOTAL		988.68	988.68
							JOURNAL 2026/10/44	TOTAL	1,977.36	1,977.36

A/P CASH DISBURSEMENTS JOURNAL
 JOURNAL ENTRIES TO BE CREATED

FUND	ACCOUNT	YEAR	PER	JNL	EFF DATE	ACCOUNT DESCRIPTION	DEBIT	CREDIT
751	JPA Operations	2026	10	44	04/07/2026			
	751-100100					Cash-General		988.68
	751-200000					Accounts Payable	988.68	
						FUND TOTAL	988.68	988.68
999	Pooled Cash	2026	10	44	04/07/2026			
	999-100100					Cash-General		988.68
	999-207510					Due to/Due From JPA Operations	988.68	
						FUND TOTAL	988.68	988.68

A/P CASH DISBURSEMENTS JOURNAL
JOURNAL ENTRIES TO BE CREATED

FUND		DUE TO	DUE FR
751	JPA Operations		988.68
999	Pooled Cash	988.68	
	TOTAL	988.68	988.68

** END OF REPORT - Generated by Thieu Chau **

A/P CASH DISBURSEMENTS JOURNAL

CASH ACCOUNT: 999 100100 Cash-General
 CHECK NO CHK DATE TYPE VENDOR NAME

CHECK NO	CHK DATE	TYPE	VENDOR NAME	INVOICE	INV DATE	PO	CHECK RUN	NET
INVOICE DTL DESC								
							CHECK 1160 TOTAL:	32,958.62
1161	04/14/2026	EFT	30536 UNIVAR SOLUTIONS INC.	53759980	03/20/2026		041426	3,120.19
				3,120.19 751820 541000	2,843 LBS CITRIC ACID			
					Supplies/Material			
			UNIVAR SOLUTIONS INC.	53780739	03/28/2026		041426	8,889.74
				8,889.74 751810 541011	42,980 LBS SODIUM BISULFITE			
					Sodium Bisulfite			
							CHECK 1161 TOTAL:	12,009.93
1162	04/14/2026	EFT	30645 VITAL COATINGS INC	284	04/07/2026		041426	14,500.00
				14,500.00 301440 900000	PAINTING AND COATING 116 SYSTEM HYDRANTS			
					Capital Asset Expenses			
							CHECK 1162 TOTAL:	14,500.00
1163	04/14/2026	EFT	3035 VWR SCIENTIFIC	8821274265	03/24/2026		041426	323.59
				323.59 701341 551000	EDTA TITRANT, SULFURIC ACID & GLOVES			
					Supplies/Material			
							CHECK 1163 TOTAL:	323.59
1164	04/14/2026	PRTD	2814 MCMaster-CARR SUPPLY CO	62015602	03/24/2026		041426	182.10
				182.10 751820 551000	ELECTRICAL SUPPLIES			
					Supplies/Material			
			MCMaster-CARR SUPPLY CO	62123523	03/25/2026		041426	312.85
				312.85 101600 541000	WATER & OPERATIONS SUPPLIES			
					Supplies/Material			
			MCMaster-CARR SUPPLY CO	62116063	03/25/2026		041426	94.85
				94.85 751820 551000	ELECTRICAL SUPPLIES			
					Supplies/Material			
							CHECK 1164 TOTAL:	589.80
1165	04/14/2026	PRTD	7770 AUTOMATIONDIRECT.COM	19035192	03/17/2026		041426	442.29
				442.29 751810 551000	PLC FOR OBS WELL			
					Supplies/Material			
							CHECK 1165 TOTAL:	442.29

A/P CASH DISBURSEMENTS JOURNAL

CASH ACCOUNT: 999 100100 Cash-General
 CHECK NO CHK DATE TYPE VENDOR NAME

CHECK NO	CHK DATE	TYPE	VENDOR NAME	INVOICE	INV DATE	PO	CHECK RUN	NET
114459	04/14/2026	PRTD	17361 ACCURATE FIRST AID SERVICES	C-3488	04/01/2026		041426	444.81
			Invoice: C-3488					
				444.81 701125 680000			FIRST AID STE SRV - RANCHO Safety	
							CHECK 114459 TOTAL:	444.81
114460	04/14/2026	PRTD	30485 ADS CORP	22085-0326	03/21/2026		041426	3,698.00
			Invoice: 22085-0326					
				924.50 130100 551500			SEWER FLOW MONITORING MARCH 2026	
				2,773.50 751800 551500			Outside Services	
							CHECK 114460 TOTAL:	3,698.00
114461	04/14/2026	PRTD	20389 AIRGAS SPECIALTY PRODUCTS	9169940755	03/06/2026		041426	7,141.16
			Invoice: 9169940755					
				7,141.16 751810 541013			30,800 LBS AMMONIUM HYDROXIDE Aqua Ammonia	
							CHECK 114461 TOTAL:	7,141.16
114462	04/14/2026	PRTD	3077 AIRGAS USA, LLC	5523947926	03/31/2026		041426	484.08
			Invoice: 5523947926					
				484.08 701002 551500			CYLINDER RENTAL MARCH 2026	
							Outside Services	
							CHECK 114462 TOTAL:	484.08
114463	04/14/2026	PRTD	30461 ALTERNATIVE HOSE INC.	6144086	03/27/2026	2260162	041426	1,373.18
			Invoice: 6144086					
				1,373.18 701 132000			STAINLESS STEEL FITTINGS	
							Storeroom & Truck Inventory	
							CHECK 114463 TOTAL:	1,373.18
114464	04/14/2026	PRTD	30729 AMAZON CAPITAL SERVICES, INC.	1PQT-139R-FP1L	03/20/2026		041426	161.10
			Invoice: 1PQT-139R-FP1L					
				161.10 751820 551000			CORRUGATED SINGLEALL PIPE	
							Supplies/Material	
			Invoice: 1C4H-KL9R-QVNV					
				278.20 701521 551000			MULTI-MIX CONTAINER & PLASTIC CONTAINER	
							Supplies/Material	
			Invoice: 1DLM-VF43-JL1D					
				27.64 701121 620000			WATER PITCHER	
							Forms, Supplies And Postage	
			Invoice: 1DQM-N9MM-PY6T					
				629.97 101600 541000			WIRE ROPES, PULLEY BLOCKS, ANCHOR CHAIN & THIMBLE	
							Supplies/Material	

A/P CASH DISBURSEMENTS JOURNAL

CASH ACCOUNT: 999 100100 Cash-General
 CHECK NO CHK DATE TYPE VENDOR NAME

CHECK NO	CHK DATE	TYPE	VENDOR NAME	INVOICE	INV DATE	PO	CHECK RUN	NET
Invoice: 1GFV-7WNK-DFXF			AMAZON CAPITAL SERVICES, INC.	1GFV-7WNK-DFXF	03/31/2026		041426	54.86
				54.86 101100 551000	FAST ACTING FUSE Supplies/Material			
Invoice: 1HQW-4WN1-RH4T			AMAZON CAPITAL SERVICES, INC.	1HQW-4WN1-RH4T	03/30/2026		041426	15.34
				15.34 751810 551000	SAFETY VEST Supplies/Material			
Invoice: 1JLT-3Q74-GQ6Q			AMAZON CAPITAL SERVICES, INC.	1JLT-3Q74-GQ6Q	03/27/2026		041426	68.80
				68.80 701331 623000	HEADLAMP Safety Equip			
Invoice: 1MJL-C3PR-FW7H			AMAZON CAPITAL SERVICES, INC.	1MJL-C3PR-FW7H	03/26/2026		041426	62.43
				62.43 701525 551000	EMERGENCY DASH STROBE LIGHTS & BAR Supplies/Material			
Invoice: 1NQY-4MV9-JYTT			AMAZON CAPITAL SERVICES, INC.	1NQY-4MV9-JYTT	03/31/2026		041426	383.30
				383.30 101900 572500	USA SEALING RING Genl Supplies/Small Tools			
Invoice: 1QCM-11TF-MNTT			AMAZON CAPITAL SERVICES, INC.	1QCM-11TF-MNTT	03/26/2026		041426	30.91
				30.91 701420 620000	HDMI MONITOR CABLE Forms, Supplies And Postage			
Invoice: 14QW-JKRW-QJF7			AMAZON CAPITAL SERVICES, INC.	14QW-JKRW-QJF7	03/25/2026		041426	394.96
				394.96 101900 572500	MARKING PAINT & SPRAY CHALK Genl Supplies/Small Tools			
Invoice: 16DF-3DHD-LCX9			AMAZON CAPITAL SERVICES, INC.	16DF-3DHD-LCX9	03/30/2026		041426	57.04
				57.04 751810 541000	EXTESION LADDER REPLACEMENT ROPE Supplies/Material			
Invoice: 16KW-94CF-VRNW			AMAZON CAPITAL SERVICES, INC.	16KW-94CF-VRNW	03/31/2026		041426	58.09
				58.09 701526 572500	FUSE PULLERS Genl Supplies/Small Tools			
Invoice: 1NLM-YCQG-DPFQ			AMAZON CAPITAL SERVICES, INC.	1NLM-YCQG-DPFQ	03/12/2026		041426	724.35
				724.35 751810 551000	ISOLATION REMOTE LEVEL CONTROLLER Supplies/Material			
Invoice: 1P39-WD93-DYH6			AMAZON CAPITAL SERVICES, INC.	1P39-WD93-DYH6	03/31/2026		041426	262.22
				262.22 701322 572500	WOOD PLUGS & PLASTIC PAINT PAIL Genl Supplies/Small Tools			
Invoice: 1YCK-FRQH-F4CK			AMAZON CAPITAL SERVICES, INC.	1YCK-FRQH-F4CK	03/30/2026		041426	10.96
				10.96 701420 543000	TOOL WALL HOOK Capital Outlay			
Invoice: 11Y3-74XY-KP7Q			AMAZON CAPITAL SERVICES, INC.	11Y3-74XY-KP7Q	04/02/2026		041426	286.41
				286.41 701521 572500	FACILITIES SUPPLIES Genl Supplies/Small Tools			

A/P CASH DISBURSEMENTS JOURNAL

CASH ACCOUNT: 999 100100 Cash-General
 CHECK NO CHK DATE TYPE VENDOR NAME

CHECK NO	CHK DATE	TYPE	VENDOR NAME	INVOICE	INV DATE	PO	CHECK RUN	NET
INVOICE DTL DESC								
114470	04/14/2026	PRTD	30535 BETTER BUSINESS PLANNING, INC	535585	03/25/2026		041426	1.55
	Invoice: 535585			1.55 701125 622000	TPA STREAM APRIL 2026			
					Outside Services			
			BETTER BUSINESS PLANNING, INC	535584	03/25/2026		041426	270.73
	Invoice: 535584			270.73 701125 622000	FSA DEBIT CARD APRIL 2026			
					Outside Services			
					CHECK		114470 TOTAL:	272.28
114471	04/14/2026	PRTD	21426 BRIGHTVIEW LANDSCAPE SERVICES, IN	9658263	02/28/2026		041426	14,245.75
	Invoice: 9658263			3,271.37 701001 551500	LANDSCAPE SRVCS FEBRUARY 2026			
				1,837.13 751820 551800	Outside Services			
				3,843.60 751810 551800	Building Maintenance			
				4,191.15 101600 551800	Building Maintenance			
				336.50 101200 551500	Building Maintenance			
				301.00 130100 551500	Outside Services			
				390.00 751200 541500	Outside Services			
				75.00 751200 541500	Outside Services			
			BRIGHTVIEW LANDSCAPE SERVICES, IN	9700833	03/31/2026		041426	14,245.75
	Invoice: 9700833			3,271.37 701001 551500	LANDSCAPE SRVCS MARCH 2026			
				1,837.13 751820 551800	Outside Services			
				3,843.60 751810 551800	Building Maintenance			
				4,191.15 101600 551800	Building Maintenance			
				336.50 101200 551500	Building Maintenance			
				301.00 130100 551500	Outside Services			
				390.00 751200 541500	Outside Services			
				75.00 751200 541500	Outside Services			
			BRIGHTVIEW LANDSCAPE SERVICES, IN	9736710	03/27/2026		041426	1,730.00
	Invoice: 9736710			1,730.00 751100 541500	REMOVING DIRT & DEBRIS			
					Outside Services			
					CHECK		114471 TOTAL:	30,221.50
114472	04/14/2026	PRTD	2539 CITY OF SIMI VALLEY	71062297	03/18/2026		041426	10,026.72
	Invoice: 71062297			10,026.72 101001 511000	PURCH WATER 1/13-3/17/26			
					Purch Water-Simi Dist#8			
					CHECK		114472 TOTAL:	10,026.72
114473	04/14/2026	PRTD	16821 CLEAN SWEEP SUPPLY CO., INC	636676	03/19/2026	2260156	041426	526.25
	Invoice: 636676			526.25 701 132000	JANITORIAL SUPPLIES			
					Storeroom & Truck Inventory			

A/P CASH DISBURSEMENTS JOURNAL

CASH ACCOUNT: 999 100100 Cash-General
 CHECK NO CHK DATE TYPE VENDOR NAME

CHECK NO	CHK DATE	TYPE	VENDOR NAME	INVOICE	INV DATE	PO	CHECK RUN	NET
CHECK 114480 TOTAL: 314.21								
114481	04/14/2026	PRTD	21573 EVERBRIDGE, INC	M93785	03/31/2026		041426	13,021.16
			Invoice: M93785	13,021.16	701230	660400	MASS NOTIFICATION 5/26/26 - 5/25/27 Public Education Programs	
CHECK 114481 TOTAL: 13,021.16								
114482	04/14/2026	PRTD	31067 EVERON, LLC	160286341	01/05/2026		041426	513.00
			Invoice: 160286341	513.00	301440	900000	SMOKE DETECTOR INSPECTION 1/2/26 Capital Asset Expenses	
			Invoice: 160487920	-540.00	301440	900000	CREDIT MEMO FOR INVOICE 160286341 Capital Asset Expenses	-540.00
			Invoice: 160758061	19,857.99	301440	900000	ALARM SYST EQUIP/MATRLS, ENGINRG DRAWINGS Capital Asset Expenses	19,857.99
CHECK 114482 TOTAL: 19,830.99								
114483	04/14/2026	PRTD	31132 EXIM ENGINEERING INC.	74611	03/27/2026	2260161	041426	3,020.30
			Invoice: 74611	3,020.30	751820	551000	CONVEYOR GEAR BOXES FOR RANCHO Supplies/Material	
			Invoice: 74649	2,350.09	751820	551000	CONVEYOR GEAR BOXES FOR RANCHO Supplies/Material	2,350.09
CHECK 114483 TOTAL: 5,370.39								
114484	04/14/2026	PRTD	2655 FERGUSON WATERWORKS #1089	0071913-2	03/23/2026	2260153	041426	3,450.72
			Invoice: 0071913-2	3,450.72	701	132000	SS REP CLAMP Storeroom & Truck Inventory	
			Invoice: 0068159-1	10,191.70	701	132000	METERS & REGISTERS Storeroom & Truck Inventory	10,191.70
			Invoice: 0069614	1,424.28	101100	541000	BUTTERFLY VALVE Supplies/Material	1,424.28
CHECK 114484 TOTAL: 15,066.70								

A/P CASH DISBURSEMENTS JOURNAL

CASH ACCOUNT: 999 100100 Cash-General
 CHECK NO CHK DATE TYPE VENDOR NAME

CHECK NO	CHK DATE	TYPE	VENDOR NAME	INVOICE	INV DATE	PO	CHECK RUN	NET
INVOICE DTL DESC								
114485	04/14/2026	PRTD	19397 DAIOHS USA INC.	SF-1155585	03/20/2026		041426	67.00
			Invoice: SF-1155585	67.00 701410 620000	MARCH 2026	COFFEE SRVC - WLK		
						Forms, Supplies And Postage		
			DAIOHS USA INC.	SF-1158830	03/25/2026		041426	94.98
			Invoice: SF-1158830	94.98 701410 620000	MARCH 2026	COFFEE SRVC - HQ		
						Forms, Supplies And Postage		
			DAIOHS USA INC.	SF-1158831	03/25/2026		041426	133.16
			Invoice: SF-1158831	133.16 701410 620000	MARCH 2026	COFFEE SRVC -OPS		
						Forms, Supplies And Postage		
			DAIOHS USA INC.	SF-1158832	03/25/2026		041426	83.01
			Invoice: SF-1158832	83.01 701410 620000	MARCH 2026	COFFEE SRVC - RLV		
						Forms, Supplies And Postage		
			DAIOHS USA INC.	SF-1158833	03/25/2026		041426	151.64
			Invoice: SF-1158833	151.64 701410 620000	MARCH 2026	COFFEE SRVC - TAPIA		
						Forms, Supplies And Postage		
						CHECK	114485 TOTAL:	529.79
114486	04/14/2026	PRTD	6770 G.I. INDUSTRIES	3198976-0283-9	04/01/2026		041426	1,025.30
			Invoice: 3198976-0283-9	338.35 701001 551500	DISP HQ & SHOP APRIL 2026			
				686.95 701002 551500	Outside Services			
			G.I. INDUSTRIES	0056602-0283-8	04/01/2026		041426	1,018.40
			Invoice: 0056602-0283-8	1,018.40 751810 551800	DISP TAPIA APRIL 2026			
						Building Maintenance		
			G.I. INDUSTRIES	0056613-0283-5	04/01/2026		041426	1,694.00
			Invoice: 0056613-0283-5	1,694.00 751810 541500	DISP TAPIA GRIT APRIL 2026			
						Outside Services		
			G.I. INDUSTRIES	3198974-0283-4	04/01/2026		041426	123.72
			Invoice: 3198974-0283-4	123.72 751820 551800	DISP RLV FARM APRIL 2026			
						Building Maintenance		
			G.I. INDUSTRIES	2590457-0283-6	04/01/2026		041426	238.38
			Invoice: 2590457-0283-6	238.38 101600 551800	DISP WLK APRIL 2026			
						Building Maintenance		
			G.I. INDUSTRIES	3198975-0283-1	04/01/2026		041426	123.72
			Invoice: 3198975-0283-1	123.72 751830 551500	DISP RLV FARM APRIL 2026			
						Outside Services		
			G.I. INDUSTRIES	3199142-0283-7	04/01/2026		041426	1,513.54
			Invoice: 3199142-0283-7	1,513.54 701002 551500	25 YD ROLLOFF DISP 3/16-3/31/26			
						Outside Services		

A/P CASH DISBURSEMENTS JOURNAL

CASH ACCOUNT: 999 100100 Cash-General
 CHECK NO CHK DATE TYPE VENDOR NAME

CHECK NO	CHK DATE	TYPE	VENDOR NAME	INVOICE	INV DATE	PO	CHECK RUN	NET
INVOICE DTL DESC								
Invoice: 0056880-0283-0			G.I. INDUSTRIES	0056880-0283-0	04/01/2026		041426	838.02
				838.02 751810 541500	DISP TAPIA RAGS 3/16-3/31/26 Outside Services			
						CHECK	114486 TOTAL:	6,575.08
114487 04/14/2026 PRTD			21168 GRANICUS LLC	220519	12/15/2025		041426	21,254.41
Invoice: 220519				11,740.95 701420 621500	WEB HOSTING/MAINT 10/16/25-10/15/26 System Support and Maintenance			
				9,513.46 701121 651600	Other Professional Serv			
						CHECK	114487 TOTAL:	21,254.41
114488 04/14/2026 PRTD			2705 HACH COMPANY	14911103	03/12/2026		041426	172.00
Invoice: 14911103				172.00 701341 551500	BENCH SERVICE PARTNERSHIP SVC PLAN 3/12/26-3/11/27 Outside Services			
						CHECK	114488 TOTAL:	172.00
114489 04/14/2026 PRTD			18594 HAROLD BECK & SONS, INC	345948	03/20/2026		041426	1,291.97
Invoice: 345948				1,291.97 751810 551000	480 VAC RETRO KIT FOR ACTUATOR Supplies/Material			
						CHECK	114489 TOTAL:	1,291.97
114490 04/14/2026 PRTD			31091 HYDREVO LLC	1743	04/02/2026		041426	10,925.00
Invoice: 1743				10,925.00 101700 551500	WATER LEAK DETECTION SERVICES Outside Services			
						CHECK	114490 TOTAL:	10,925.00
114491 04/14/2026 PRTD			19169 INDUSTRIAL RADIO COMMUNICATIONS C	275494	03/04/2026		041426	2,794.54
Invoice: 275494				2,794.54 701526 622500	RADIO INSTALLATION NEW VEHICLES #982/984/988 Radio Maintenance Expense			
						CHECK	114491 TOTAL:	2,794.54
114492 04/14/2026 PRTD			4144 INTERSTATE BATTERY SYSTEMS	130038593	03/09/2026		041426	333.77
Invoice: 130038593				333.77 701525 551000	BATTERIES/INVENTORY FOR FLEET VEHICLES Supplies/Material			
						CHECK	114492 TOTAL:	333.77

A/P CASH DISBURSEMENTS JOURNAL

CASH ACCOUNT: 999 100100 Cash-General
 CHECK NO CHK DATE TYPE VENDOR NAME

CHECK NO	CHK DATE	TYPE	VENDOR NAME	INVOICE	INV DATE	PO	CHECK RUN	NET
INVOICE DTL DESC								
114493	04/14/2026	PRTD	20823 INVOICE CLOUD INC.	964-2026_ 3	03/31/2026		041426	10,450.23
			Invoice: 964-2026_ 3	10,450.23 701221 622000	INVOICE CLOUD FEE MARCH 2026 Outside Services			
						CHECK	114493 TOTAL:	10,450.23
114494	04/14/2026	PRTD	16393 JACK HENRY & ASSOCIATES, INC.	5211121	02/28/2026		041426	937.44
			Invoice: 5211121	937.44 701420 620000	CANON CHECK SCANNER Forms, Supplies And Postage			
			Invoice: 5212526					
			JACK HENRY & ASSOCIATES, INC.	5212526	02/28/2026		041426	55.15
				55.15 701420 620000	TONER Forms, Supplies And Postage			
						CHECK	114494 TOTAL:	992.59
114495	04/14/2026	PRTD	2547 LOS ANGELES COUNTY SANITATION DIS	48892/033126	03/31/2026		041426	1,011.79
			Invoice: 48892/033126	1,011.79 751810 541500	TAPIA GRIT HAULING MARCH 2026 Outside Services			
						CHECK	114495 TOTAL:	1,011.79
114496	04/14/2026	PRTD	2611 LA DWP	8512601000/033026	03/30/2026		041426	46.00
			Invoice: 8512601000/033026	46.00 101700 540510	RECTIFIER 3/2-3/30/26 Energy			
						CHECK	114496 TOTAL:	46.00
114497	04/14/2026	PRTD	16244 LIBERTY PROCESS EQUIPMENT, INC.	0112310-IN	03/23/2026	2260164	041426	9,897.18
			Invoice: 0112310-IN	9,897.18 751820 551000	MOYNO PUMP REFURBISH PARTS FOR RANCHO Supplies/Material			
						CHECK	114497 TOTAL:	9,897.18
114498	04/14/2026	PRTD	8484 LINDE GAS AND EQUIPMENT INC.	55057474	02/22/2026		041426	58.27
			Invoice: 55057474	58.27 101100 541000	CYLINDER RENTAL 1/20-2/20/26 Supplies/Material			
						CHECK	114498 TOTAL:	58.27
114499	04/14/2026	PRTD	2793 LISTER RENTS INC	178886.1.2	03/04/2026		041426	245.08
			Invoice: 178886.1.2	245.08 101700 551000	CONCRETE MIXER RENTAL & SLURRY Supplies/Material			
			LISTER RENTS INC	179331.1.2	03/31/2026		041426	313.72

A/P CASH DISBURSEMENTS JOURNAL

CASH ACCOUNT: 999 100100 Cash-General
 CHECK NO CHK DATE TYPE VENDOR NAME

CHECK NO	CHK DATE	TYPE	VENDOR NAME	INVOICE	INV DATE	PO	CHECK RUN	NET
Invoice: 179331.1.2				313.72	101700	551000	INVOICE DTL DESC CONCRETE MIXER RENTAL & SLURRY Supplies/Material	
							CHECK 114499 TOTAL:	558.80
114500	04/14/2026	PRTD	31110 MADDAUS WATER MANAGEMENT INC.	589-02	03/10/2026		041426	5,041.25
Invoice: 589-02				5,041.25	701223	651600	WATER CONSERVATN MODELING/TECH SVCS FEBRUARY 2026 Other Professional Serv	
							CHECK 114500 TOTAL:	5,041.25
114501	04/14/2026	PRTD	31106 MANATT, PHELPS, & PHILLIPS LLP	688362	03/19/2026		041426	6,250.00
Invoice: 688362				6,250.00	101900	651100	STATE ADVOCACY MARCH 2026 Outside Services	
							CHECK 114501 TOTAL:	6,250.00
114502	04/14/2026	PRTD	31120 MDJ MANAGEMENT, LLC	LVD 1001.1	03/18/2026		041426	15,885.47
Invoice: LVD 1001.1				15,885.47	301440	900000	BLDG 7 BALCONY REPAIR 3/18/26 Capital Asset Expenses	
							CHECK 114502 TOTAL:	15,885.47
114503	04/14/2026	PRTD	30037 MONTROSE ENVIRONMENTAL SOLUTIONS	CINV-495860	03/31/2026		041426	4,500.00
Invoice: CINV-495860				4,500.00	101100	542000	AER REPORTING FOR CORNELL, CONDUIT, AND JBR P/S Permits and Fees	
							CHECK 114503 TOTAL:	4,500.00
114504	04/14/2026	PRTD	30590 NBS GOVERNMENT FINANCE GROUP	202603-1431	03/20/2026		041426	3,422.12
Invoice: 202603-1431				3,422.12	301001	713100	STANDBY CHARGE 4/1-6/30/26 Standby Chg-Outside Svc	
							CHECK 114504 TOTAL:	3,422.12
114505	04/14/2026	PRTD	30922 NORTH HILLS RECYCLING INC.	33647	03/26/2026		041426	3,463.72
Invoice: 33647				3,463.72	751820	541080	240 1/4 INCH WOOD CHIP BULK SUPPLY Amendment	
			NORTH HILLS RECYCLING INC.	33645	03/26/2026		041426	1,731.86
Invoice: 33645				1,731.86	751820	541080	120 1/4 INCH WOOD CHIP BULK SUPPLY Amendment	
							CHECK 114505 TOTAL:	5,195.58

A/P CASH DISBURSEMENTS JOURNAL

CASH ACCOUNT: 999 100100 Cash-General
 CHECK NO CHK DATE TYPE VENDOR NAME

CHECK NO	CHK DATE	TYPE	VENDOR NAME	INVOICE	INV DATE	PO	CHECK RUN	NET
114506	04/14/2026	PRTD	30269 PAPER RECYCLING & SHREDDING SPECI	624709	03/10/2026		041426	68.00
			Invoice: 624709					
				68.00 701121 623500			ON SITE DOC SHREDDING 3/10/26 Records Management	
							CHECK 114506 TOTAL:	68.00
114507	04/14/2026	PRTD	30458 PIONEER AMERICAS, LLC (OLIN CORP)	900695685	03/24/2026		041426	9,108.27
			Invoice: 900695685					
				9,108.27 751810 541014			4,784 GAL SODIUM HYPOCHLORITE Sodium Hypochlorite	
			Invoice: 900698886					
			PIONEER AMERICAS, LLC (OLIN CORP)	900698886	03/31/2026		041426	9,355.77
				9,355.77 751810 541014			4,914 GAL SODIUM HYPOCHLORITE Sodium Hypochlorite	
							CHECK 114507 TOTAL:	18,464.04
114508	04/14/2026	PRTD	2585 J. HARRIS INDUSTRIAL WATER TREATM	2397455	03/31/2026		041426	97.65
			Invoice: 2397455					
				97.65 701341 551500			14" POLISHER/MIXED BED TANK RENTAL APRIL 2026 Outside Services	
			Invoice: 2397735					
			J. HARRIS INDUSTRIAL WATER TREATM	2397735	03/31/2026		041426	35.88
				35.88 101600 541000			8" MIXED BED TANK RENTAL APRIL 2026 Supplies/Material	
							CHECK 114508 TOTAL:	133.53
114509	04/14/2026	PRTD	20124 RON'S PORTABLE WELDING	7047	03/30/2026		041426	560.00
			Invoice: 7047					
				560.00 101700 551500			WELDING SVCS 3/30/26 Outside Services	
							CHECK 114509 TOTAL:	560.00
114510	04/14/2026	PRTD	4586 ROYAL INDUSTRIAL SOLUTIONS	9009-1067842	03/26/2026		041426	584.81
			Invoice: 9009-1067842					
				584.81 751810 551000			MOTOR DISCONNECT SWITCH 3 POLE 60 AMP Supplies/Material	
							CHECK 114510 TOTAL:	584.81
114511	04/14/2026	PRTD	2957 SOUTHERN CALIFORNIA EDISON (M-BIL 75690/032726	75690/032726	03/27/2026		041426	2,077.42
			Invoice: 75690/032726					
				2,077.42 751750 540510			BLDG 1 HM-PWP 2/24-3/24/26 8,532 KH Energy	
			Invoice: 77683/032726					
			SOUTHERN CALIFORNIA EDISON (M-BIL 77683/032726	77683/032726	03/27/2026		041426	977.41
				977.41 751750 540510			BLDG 1 EV-PWP 2/24-3/24/26 3,194 KH Energy	

A/P CASH DISBURSEMENTS JOURNAL

CASH ACCOUNT: 999 100100 Cash-General
 CHECK NO CHK DATE TYPE VENDOR NAME

CHECK NO	CHK DATE	TYPE	VENDOR NAME	INVOICE	INV DATE	PO	CHECK RUN	NET
INVOICE DTL DESC								
Invoice: 90504/033126			SOUTHERN CALIFORNIA EDISON (M-BIL	90504/033126	03/31/2026		041426	1,167.91
				1,167.91 751810 678800	N. CYN P/S 1/30-3/02/26		2,184 KH	
					District Sprayfield			
Invoice: 45743/040126			SOUTHERN CALIFORNIA EDISON (M-BIL	45743/040126	04/01/2026		041426	38,772.90
				19,386.45 751127 540510	RW P/S 3/3-3/31/26		103,342 KH	
				19,386.45 751128 540510	Energy			
					Energy			
					CHECK		114511 TOTAL:	42,995.64
114512 04/14/2026 PRD	2958		SOUTHERN CALIFORNIA GAS CO (M-bil	06551212001/040626	04/06/2026		041426	16.45
Invoice: 06551212001/040626				16.45 101109 540530	JBR P/S 3/4-4/2/26		1 THERMS	
					Gas			
Invoice: 05721104007/040826			SOUTHERN CALIFORNIA GAS CO (M-bil	05721104007/040826	04/08/2026		041426	19.55
				19.55 101110 540530	CORNELL P/S 3/6-4/6/26		2 THERMS	
					Gas			
Invoice: 18121142006/040826			SOUTHERN CALIFORNIA GAS CO (M-bil	18121142006/040826	04/08/2026		041426	336.15
				336.15 751820 540530	RANCHO 3/6-4/6/26		143 THERMS	
					Gas			
Invoice: 01951140001/040826			SOUTHERN CALIFORNIA GAS CO (M-bil	01951140001/040826	04/08/2026		041426	1,108.24
				1,108.24 751810 540530	TAPIA 3/6-4/6/26		657 THERMS	
					Gas			
Invoice: 03001136005/040826			SOUTHERN CALIFORNIA GAS CO (M-bil	03001136005/040826	04/08/2026		041426	2,448.42
				1,836.32 701001 540530	HQ & OPS 3/6-4/6/26		1,631 THERMS	
				612.10 701002 540530	Gas			
					Gas			
					CHECK		114512 TOTAL:	3,928.81
114513 04/14/2026 PRD	30414		SYNAGRO WEST, LLC	66110	03/03/2026		041426	24,632.70
Invoice: 66110				24,632.70 751820 543000	BIOSOLIDS DISPOSAL FEBRUARY 2026			
					Capital Outlay			
					CHECK		114513 TOTAL:	24,632.70
114514 04/14/2026 PRD	21137		TESLA, INC.	40874792	04/02/2026		041426	10,300.45
Invoice: 40874792				5,150.23 751127 540511	RW P/S MARCH 2026 SOLAR		98,099.520 KWH	
				5,150.22 751128 540511	Energy-Solar			
					Energy-Solar			
					CHECK		114514 TOTAL:	10,300.45

A/P CASH DISBURSEMENTS JOURNAL

CASH ACCOUNT: 999 100100 Cash-General
 CHECK NO CHK DATE TYPE VENDOR NAME

CHECK NO	CHK DATE	TYPE	VENDOR NAME	INVOICE	INV DATE	PO	CHECK RUN	NET
INVOICE DTL DESC								
114515	04/14/2026	PRTD	19135 TRANSUNION RISK AND ALTERNATIVE D	974571-202603-1	04/01/2026		041426	160.00
			Invoice: 974571-202603-1					
				160.00 701221 620000			SSN VERIFICATION MARCH 2026 Forms, Supplies And Postage	
							CHECK 114515 TOTAL:	160.00
114516	04/14/2026	PRTD	30159 TRILLIUM HOLDCO LLC	549278	03/25/2026		041426	23,770.10
			Invoice: 549278					
				23,770.10 751101 540511			ELEC CHARGES SOLAR FEBRUARY 2026 Energy-Solar	
							CHECK 114516 TOTAL:	23,770.10
114517	04/14/2026	PRTD	21252 TYLER TECHNOLOGIES, INC	CI100-00261173	02/20/2026		041426	243,422.31
			Invoice: CI100-00261173					
				243,422.31 701420 621500			APPLICATION SRVS 4/1/26-3/31/27 System Support and Maintenance	
							CHECK 114517 TOTAL:	243,422.31
114518	04/14/2026	PRTD	8764 UNITED RIBBON COMPANY, INC.	5598508	02/28/2026		041426	152.54
			Invoice: 5598508					
				152.54 751820 551000			RANCHO TONER Supplies/Material	
			Invoice: 5599017					
				305.32 751810 551000			TONER Supplies/Material	305.32
			Invoice: 5599084					
				102.34 701210 572500			TONER Genl Supplies/Small Tools	102.34
							CHECK 114518 TOTAL:	560.20
114519	04/14/2026	PRTD	2325 UNITED RENTALS, INC	259483003-001	03/22/2026		041426	5,441.29
			Invoice: 259483003-001					
				5,441.29 301440 900000			TRANSFER SWITCH RENTAL MCCOY P/S Capital Asset Expenses	
			Invoice: 251714060-008					
				4,189.16 130100 551500			TRANSFER SWITCH RENTAL Outside Services	4,189.16
							CHECK 114519 TOTAL:	9,630.45
114520	04/14/2026	PRTD	20935 US METRO GROUP, INC.	111351	03/31/2026		041426	15,567.38
			Invoice: 111351					
				7,670.79 701001 551500			JANITORIAL SRV MARCH 2026 Outside Services	
				3,336.79 701002 551500			Outside Services	

A/P CASH DISBURSEMENTS JOURNAL

CASH ACCOUNT: 999 100100 Cash-General
 CHECK NO CHK DATE TYPE VENDOR NAME

CHECK NO	CHK DATE	TYPE	VENDOR NAME	INVOICE	INV DATE	PO	CHECK RUN	NET
				INVOICE DTL DESC				
				311.84 101600	551800		Building Maintenance	
				926.73 751750	551800		Building Maintenance	
				1,713.14 751810	551800		Building Maintenance	
				1,608.09 751820	551800		Building Maintenance	
						CHECK	114520 TOTAL:	15,567.38
114521	04/14/2026	PRTD	2780 VALLEY NEWS GROUP	3-26				
			Invoice: 3-26				03/26/2026 041426	250.00
				250.00 751840	660400		DISPLAY AD- FREE COMPOST 3/26/26 Public Education Programs	
						CHECK	114521 TOTAL:	250.00
114522	04/14/2026	PRTD	30056 VERIZON WIRELESS	6139583152				
			Invoice: 6139583152				03/26/2026 041426	576.15
				576.15 701224	540520		WIRELESS SVC 2/27-3/26/26 Telephone	
						CHECK	114522 TOTAL:	576.15
114523	04/14/2026	PRTD	2701 GRAINGER	9832142013				
			Invoice: 9832142013				03/05/2026 041426	313.18
				313.18 101900	572500		BRAKE PARTS & SEALING TAPE Genl Supplies/Small Tools	
			Invoice: 9835085581				03/09/2026 041426	102.61
				102.61 101900	572500		BUTTON BATTERY, LOCKOUT TAG & PLASTIC TAG Genl Supplies/Small Tools	
			Invoice: 9837120758				03/10/2026 041426	197.08
				197.08 101900	572500		COIN CELL BATTERY & THREAD SEALANT TAPE Genl Supplies/Small Tools	
			Invoice: 9841472427				03/13/2026 041426	33.12
				33.12 101900	572500		ALKALINE BATTERIES Genl Supplies/Small Tools	
			Invoice: 9842955057				03/16/2026 041426	255.94
				255.94 101900	572500		FLANGE GASKET Genl Supplies/Small Tools	
			Invoice: 9842955065				03/16/2026 041426	26.23
				26.23 101900	572500		PAINT TRAY LINER Genl Supplies/Small Tools	
			Invoice: 9843369480				03/16/2026 041426	218.07
				218.07 101900	572500		FLANGE GASKET Genl Supplies/Small Tools	
			Invoice: 9843613473				03/16/2026 041426	259.45
							FULL FACE FLANGE GASKET	

A/P CASH DISBURSEMENTS JOURNAL

CASH ACCOUNT: 999 100100 Cash-General
 CHECK NO CHK DATE TYPE VENDOR NAME

CHECK NO	CHK DATE	TYPE	VENDOR NAME	INVOICE	INV DATE	PO	CHECK RUN	NET
Invoice: 1-1-1024623				275.00	701526	623000		
							INVOICE DTL DESC	
							SAFETY FOOTWEAR B. LOPEZ	
							Safety Equipment	
							CHECK 114526 TOTAL:	547.11
114527	04/14/2026	PRTD	30527 WORLDWIDE EXPRESS	260308W001538	03/11/2026		041426	10.36
Invoice: 260308W001538				10.36	701410	620000		
							OUTGOING UPS FREIGHT	
							Forms, Supplies And Postage	
							CHECK 114527 TOTAL:	10.36
				NUMBER OF CHECKS	83	*** CASH ACCOUNT TOTAL ***		790,623.31
				TOTAL PRINTED CHECKS		COUNT	AMOUNT	
				TOTAL EFT'S		73	717,719.67	
						10	72,903.64	
				*** GRAND TOTAL ***				790,623.31

A/P CASH DISBURSEMENTS JOURNAL

JOURNAL ENTRIES TO BE CREATED

CLERK: 3296tchau

YEAR PER	JNL	SRC ACCOUNT	JNL DATE	JNL DESC	REF 1	REF 2	REF 3	ACCOUNT DESC LINE DESC	T OB	DEBIT	CREDIT
2026	10	188									
APP	751-200000		04/14/2026	041426	041426			Accounts Payable AP CASH DISBURSEMENTS JOURNAL		276,076.29	
APP	999-100100		04/14/2026	041426	041426			Cash-General AP CASH DISBURSEMENTS JOURNAL			790,623.31
APP	701-200000		04/14/2026	041426	041426			Accounts Payable AP CASH DISBURSEMENTS JOURNAL		359,384.23	
APP	101-200000		04/14/2026	041426	041426			Accounts Payable AP CASH DISBURSEMENTS JOURNAL		84,949.73	
APP	301-200000		04/14/2026	041426	041426			Accounts Payable AP CASH DISBURSEMENTS JOURNAL		63,360.88	
APP	130-200000		04/14/2026	041426	041426			Accounts Payable AP CASH DISBURSEMENTS JOURNAL		5,715.66	
APP	754-200000		04/14/2026	041426	041426			Accounts Payable AP CASH DISBURSEMENTS JOURNAL		1,136.52	
GENERAL LEDGER TOTAL										790,623.31	790,623.31
APP	999-207510		04/14/2026	041426	041426			Due to/Due FromJPA Operations		276,076.29	
APP	751-100100		04/14/2026	041426	041426			Cash-General			276,076.29
APP	999-207010		04/14/2026	041426	041426			Due to/Due FromInternal Svs		359,384.23	
APP	701-100100		04/14/2026	041426	041426			Cash-General			359,384.23
APP	999-201010		04/14/2026	041426	041426			Due to/Due Frm Potable Wtr Ops		84,949.73	
APP	101-100100		04/14/2026	041426	041426			Cash-General			84,949.73
APP	999-203010		04/14/2026	041426	041426			Due to/Due FrmPotable Wtr Repl		63,360.88	
APP	301-100100		04/14/2026	041426	041426			Cash-General			63,360.88
APP	999-201300		04/14/2026	041426	041426			Due to/Due FrmSanitation Ops		5,715.66	
APP	130-100100		04/14/2026	041426	041426			Cash-General			5,715.66
APP	999-207540		04/14/2026	041426	041426			Due to/Due FromJPA Replacement		1,136.52	
APP	754-100100		04/14/2026	041426	041426			Cash-General			1,136.52
SYSTEM GENERATED ENTRIES TOTAL										790,623.31	790,623.31
JOURNAL 2026/10/188 TOTAL										1,581,246.62	1,581,246.62

A/P CASH DISBURSEMENTS JOURNAL
 JOURNAL ENTRIES TO BE CREATED

FUND ACCOUNT	YEAR PER	JNL	EFF DATE	ACCOUNT DESCRIPTION	DEBIT	CREDIT
101 Potable Water Operations 101-100100 101-200000	2026 10	188	04/14/2026	Cash-General Accounts Payable	84,949.73	84,949.73
				FUND TOTAL	84,949.73	84,949.73
130 Sanitation Operations 130-100100 130-200000	2026 10	188	04/14/2026	Cash-General Accounts Payable	5,715.66	5,715.66
				FUND TOTAL	5,715.66	5,715.66
301 Potable wtr Replacement Fund 301-100100 301-200000	2026 10	188	04/14/2026	Cash-General Accounts Payable	63,360.88	63,360.88
				FUND TOTAL	63,360.88	63,360.88
701 Internal Service Fund 701-100100 701-200000	2026 10	188	04/14/2026	Cash-General Accounts Payable	359,384.23	359,384.23
				FUND TOTAL	359,384.23	359,384.23
751 JPA Operations 751-100100 751-200000	2026 10	188	04/14/2026	Cash-General Accounts Payable	276,076.29	276,076.29
				FUND TOTAL	276,076.29	276,076.29
754 JPA Replacement 754-100100 754-200000	2026 10	188	04/14/2026	Cash-General Accounts Payable	1,136.52	1,136.52
				FUND TOTAL	1,136.52	1,136.52
999 Pooled Cash 999-100100 999-201010 999-201300 999-203010 999-207010 999-207510 999-207540	2026 10	188	04/14/2026	Cash-General Due to/Due Frm Potable Wtr Ops Due to/Due Frm Sanitation Ops Due to/Due Frm Potable wtr Repl Due to/Due From Internal Svs Due to/Due From JPA Operations Due to/Due From JPA Replacement	84,949.73 5,715.66 63,360.88 359,384.23 276,076.29 1,136.52	790,623.31
				FUND TOTAL	790,623.31	790,623.31

A/P CASH DISBURSEMENTS JOURNAL
 JOURNAL ENTRIES TO BE CREATED

FUND		DUE TO	DUE FR
101	Potable Water Operations		84,949.73
130	Sanitation Operations		5,715.66
301	Potable Wtr Replacement Fund		63,360.88
701	Internal Service Fund		359,384.23
751	JPA Operations		276,076.29
754	JPA Replacement		1,136.52
999	Pooled Cash		
		790,623.31	
TOTAL		790,623.31	790,623.31

** END OF REPORT - Generated by Thieu Chau **

A/P CASH DISBURSEMENTS JOURNAL

CASH ACCOUNT: 999 100100 Cash-General
 CHECK NO CHK DATE TYPE VENDOR NAME

CHECK NO	CHK DATE	TYPE	VENDOR NAME	INVOICE	INV DATE	PO	CHECK RUN	NET
1170	04/21/2026	EFT	30119 ATS COMMUNICATIONS	03-2026	04/02/2026		042126	4,118.75
			Invoice: 03-2026					
				4,118.75	701310	552500		
							INVOICE DTL DESC	
							FEBUARY 2026 CELL SITE MGMT Consulting Services	
							CHECK	1170 TOTAL: 4,118.75
1171	04/21/2026	EFT	11330 DIAL SECURITY	530434	04/01/2026		042126	1,527.21
			Invoice: 530434					
				19.29	751820	551800	APRIL 2026 MONTHLY SVCS Building Maintenance	
				45.03	751820	551800	Building Maintenance	
				45.03	751830	551500	Outside Services	
				45.03	101600	551800	Building Maintenance	
				160.79	101600	551800	Building Maintenance	
				100.68	701001	551500	Outside Services	
				88.41	701001	551500	Outside Services	
				456.63	701001	551500	Outside Services	
				146.64	701002	551500	Outside Services	
				71.09	751750	551500	Outside Services	
				348.59	751810	551800	Building Maintenance	
							CHECK	1171 TOTAL: 1,527.21
1172	04/21/2026	EFT	19548 GRM INFORMATION MANAGEMENT SERVIC	0549851	03/31/2026		042126	427.17
			Invoice: 0549851					
				427.17	701121	623500	APRIL 2026 RECORD STORAGE Records Management	
							CHECK	1172 TOTAL: 427.17
1173	04/21/2026	EFT	7421 HAMNER, JEWELL AND ASSOCIATES	205494	04/02/2026		042126	1,455.00
			Invoice: 205494					
				1,455.00	101700	541500	EASMNT ACQUISTN SVCS CALAMIGOS MARCH 2026 Outside Services	
							CHECK	1173 TOTAL: 1,455.00
1174	04/21/2026	EFT	20779 SAND MATERIALS & AGGREGATE SALES, 95333		04/07/2026		042126	817.61
			Invoice: 95333					
				817.61	101700	551000	25.61 TONS FILL SAND Supplies/Material	
							CHECK	1174 TOTAL: 817.61
1175	04/21/2026	EFT	14479 STEPHEN J. BIGILEN	3-26-26	03/26/2026		042126	800.00
			Invoice: 3-26-26					
				800.00	751840	651600	VIDEO SRV- JPA MTGS MARCH 2026 Other Professional Serv	
			STEPHEN J. BIGILEN	3-27-26	03/27/2026		042126	800.00
			Invoice: 3-27-26					
				800.00	701112	651600	VIDEO SRV- OCEANWELLS MTGS MARCH 2026 Other Professional Serv	

A/P CASH DISBURSEMENTS JOURNAL

CASH ACCOUNT: 999 100100 Cash-General
 CHECK NO CHK DATE TYPE VENDOR NAME

CHECK NO	CHK DATE	TYPE	VENDOR NAME	INVOICE	INV DATE	PO	CHECK RUN	NET
INVOICE DTL DESC								
Invoice: 3-30-26			STEPHEN J. BIGILEN	3-30-26	03/30/2026		042126	2,400.00
			2,400.00 701112 651600		VIDEO SRV- LV MTGS FEBRUARY 2026 Other Professional Serv			
					CHECK		1175 TOTAL:	4,000.00
1176 04/21/2026 EFT	Invoice: 19930	17645	TORO ENTERPRISES, INC.	19930	03/31/2026		042126	84,200.87
			84,200.87 101700 551500		8215 WOODGL DR & RIDGE DR - TANK SITE REMEDIATION Outside Services			
Invoice: 19898			TORO ENTERPRISES, INC.	19898	03/31/2026		042126	6,060.78
			6,060.78 101700 551500		STUNT RD - 14" WATER MAIN REPAIR Outside Services			
					CHECK		1176 TOTAL:	90,261.65
1177 04/21/2026 EFT	Invoice: 19897	17645	TORO ENTERPRISES, INC.	19897	03/31/2026		042126	6,225.55
			6,225.55 101700 551500		29876 VISTA DE ARROYO - MISC PAVING IN DISTRICT Outside Services			
Invoice: 19895			TORO ENTERPRISES, INC.	19895	03/31/2026		042126	81,012.67
			81,012.67 301440 900000		ON-CALL VALVE INSTALL AGOURA RD BACKFLOW Capital Asset Expenses			
					CHECK		1177 TOTAL:	87,238.22
1178 04/21/2026 EFT	Invoice: 1534	30913	WATER RESOURCES ECONOMICS	1534	04/04/2026		042126	4,135.00
			4,135.00 701410 652200		RATE STUDY MARCH 2026 Mgmt Consultant Fees			
					CHECK		1178 TOTAL:	4,135.00
1179 04/21/2026 EFT	Invoice: 9212	30388	WATERWISE CONSULTING, INC	9212	03/31/2026		042126	7,205.28
			7,205.28 101800 670900		CUSTOMER EVALS MARCH 2026 Res. ET Irrigation Controller			
					CHECK		1179 TOTAL:	7,205.28
1180 04/21/2026 PRTD	Invoice: 2026-180584	2317	STRICKBINE PUBLISHING, INC	2026-180584	04/03/2026		042126	576.00
			576.00 751840 660400		1/4 DISPLAY AD - FREE COMPOST 4/3/26 Public Education Programs			
					CHECK		1180 TOTAL:	576.00

A/P CASH DISBURSEMENTS JOURNAL

CASH ACCOUNT: 999 100100 Cash-General
 CHECK NO CHK DATE TYPE VENDOR NAME

CHECK NO	CHK DATE	TYPE	VENDOR NAME	INVOICE	INV DATE	PO	CHECK RUN	NET
1181	04/21/2026	PRTD	2727 IDEXX LABORATORIES	3197758615	04/01/2026		042126	3,518.68
			Invoice: 3197758615					
			3,518.68 701341 551000					
							COLILERT & SAMPLE BOTTLES Supplies/Material	
							CHECK	1181 TOTAL: 3,518.68
1182	04/21/2026	PRTD	2814 MCMASTER-CARR SUPPLY CO	62602934	04/02/2026		042126	133.63
			Invoice: 62602934					
			133.63 101600 541000					
							PULLEY, CHANNEL CAP, WIRE ROPE & SLEEVE Supplies/Material	
							CHECK	1182 TOTAL: 133.63
1183	04/21/2026	PRTD	4525 HARRINGTON INDUSTRIAL PLASTICS IN	005E9567	04/10/2026	2260155	042126	4,358.84
			Invoice: 005E9567					
			4,358.84 751750 541000					
							PUMP AND KIT SEAL FOR WESTLAKE FP Supplies	
							CHECK	1183 TOTAL: 4,358.84
1184	04/21/2026	PRTD	7770 AUTOMATIONDIRECT.COM	19066762	03/26/2026		042126	830.26
			Invoice: 19066762					
			830.26 751820 551000					
							ELECTRICAL SUPPLIES Supplies/Material	
							CHECK	1184 TOTAL: 830.26
114528	04/21/2026	PRTD	17361 ACCURATE FIRST AID SERVICES	C-3489	04/01/2026		042126	243.17
			Invoice: C-3489					
			243.17 701125 680000					
							FIRST AID STE SRV - HQ Safety	
							CHECK	114528 TOTAL: 243.17
114529	04/21/2026	PRTD	30339 ALESHIRE & WYNDER, LLP	LVMWD/FEBRUARY'26	02/28/2026		042126	35,307.10
			Invoice: LVMWD/FEBRUARY'26					
			9,045.00 701121 650000					
			2,376.00 701121 623500					
			924.00 754440 900000					
			1,452.00 701121 687200					
			1,326.00 701122 687200					
			18,365.50 701121 650000					
			1,818.60 701122 687200					
							LEGAL SERVICES- FEBRUARY 2026 Legal Services Records Management Capital Asset Expenses Outside Services Outside Services Legal Services Outside Services	
							CHECK	114529 TOTAL: 35,307.10
114530	04/21/2026	PRTD	30729 AMAZON CAPITAL SERVICES, INC.	1C4G-JLQ1-K96T	04/03/2026		042126	186.48
			Invoice: 1C4G-JLQ1-K96T					
			186.48 101100 541000					
							WATER JUGS Supplies/Material	

A/P CASH DISBURSEMENTS JOURNAL

CASH ACCOUNT: 999 100100 Cash-General
 CHECK NO CHK DATE TYPE VENDOR NAME

CHECK NO	CHK DATE	TYPE	VENDOR NAME	INVOICE	INV DATE	PO	CHECK RUN	NET
INVOICE DTL DESC								
Invoice: 1DRT-XLDT-HLQR			AMAZON CAPITAL SERVICES, INC.	1DRT-XLDT-HLQR	04/06/2026		042126	177.41
			177.41 701420 543000		NETWORK & SECURITY SUPPLIES Capital Outlay			
Invoice: 19ND-P9YP-CJVF			AMAZON CAPITAL SERVICES, INC.	19ND-P9YP-CJVF	04/07/2026		042126	37.26
			37.26 701322 572500		ADJUSTABLE HYDRANT WRENCH Genl Supplies/Small Tools			
Invoice: 13HJ-TPVR-KYH4			AMAZON CAPITAL SERVICES, INC.	13HJ-TPVR-KYH4	03/02/2026		042126	-13.80
			-13.80 101600 541000		CR ON INV#1DF9-QHT3-RKQT Supplies/Material			
Invoice: 1VT4-4L76-LRHM			AMAZON CAPITAL SERVICES, INC.	1VT4-4L76-LRHM	03/02/2026		042126	-13.80
			-13.80 101600 541000		CR ON INV#1DF9-QHT3-RKQT Supplies/Material			
Invoice: 1JNT-T3HM-QN7Y			AMAZON CAPITAL SERVICES, INC.	1JNT-T3HM-QN7Y	02/23/2026		042126	306.80
			306.80 701525 551000		BACKRACK HARDWARE KIT & ROOFTOP STROBE LIGHT Supplies/Material			
Invoice: 11N1-N3KG-FVP4			AMAZON CAPITAL SERVICES, INC.	11N1-N3KG-FVP4	02/24/2026		042126	28.52
			28.52 701521 572500		WIDE BEAM HEAD LAMP Genl Supplies/Small Tools			
Invoice: 11V7-439T-D7RH			AMAZON CAPITAL SERVICES, INC.	11V7-439T-D7RH	02/24/2026		042126	331.27
			331.27 751820 551000		PULSAFEEDER Supplies/Material			
Invoice: 1P39-WD93-3RHV			AMAZON CAPITAL SERVICES, INC.	1P39-WD93-3RHV	03/31/2026		042126	324.02
			324.02 101600 541000		WATER OPERATIONS SUPPLIES Supplies/Material			
Invoice: 1WGH-R1N3-74T3			AMAZON CAPITAL SERVICES, INC.	1WGH-R1N3-74T3	04/08/2026		042126	76.81
			76.81 101600 541000		SUPERPOWER BUNK WRAP KIT ROLL Supplies/Material			
							CHECK 114530 TOTAL:	1,440.97
114531	04/21/2026	PRTD	2397 AQUATIC BIOASSAY & CONSULTING	LVS0426.0230	04/09/2026		042126	1,040.00
			Invoice: LVS0426.0230					
			1,040.00 751810 571520		CHRONIC TOXICITY TESTING Other Laboratory Serv			
							CHECK 114531 TOTAL:	1,040.00
114532	04/21/2026	PRTD	19264 ARNOLD LAROCHELLE MATHEWS VANCONA	14188	04/08/2026		042126	800.00
			Invoice: 14188					
			800.00 751840 687200		JPA COUNSEL SRV MARCH 2026 Outside Services			

A/P CASH DISBURSEMENTS JOURNAL

CASH ACCOUNT: 999 100100 Cash-General
 CHECK NO CHK DATE TYPE VENDOR NAME

INVOICE	INV DATE	PO	CHECK RUN	NET
INVOICE DTL DESC				
			CHECK 114532 TOTAL:	800.00
114533 04/21/2026 PRTD 2404 ASTRA BACKFLOW INC	INV-020461	04/07/2026 2260160	042126	50,045.00
Invoice: INV-020461	50,045.00 701 132000	PRESSURE REGULATORS Storeroom & Truck Inventory		
			CHECK 114533 TOTAL:	50,045.00
114534 04/21/2026 PRTD 16253 AT&T MOBILITY	287319785901x041026	04/02/2026	042126	4,698.58
Invoice: 287319785901x041026		MOBILITY FOUNDATION 3/3/26-4/2/26 ACT#287319785901		
	249.18 101300 540520	Telephone		
	40.74 701121 540520	Telephone		
	86.22 701122 540520	Telephone		
	40.74 701220 540520	Telephone		
	797.59 701221 540520	Telephone		
	81.48 701224 540520	Telephone		
	45.48 701226 540520	Telephone		
	40.74 701230 540520	Telephone		
	250.61 701322 540520	Telephone		
	1,372.86 701331 540520	Telephone		
	254.23 701420 540520	Telephone		
	45.48 701440 540520	Telephone		
	136.44 701510 540520	Telephone		
	86.22 701520 540520	Telephone		
	495.03 701521 540520	Telephone		
	172.44 701526 540520	Telephone		
	167.70 701530 540520	Telephone		
	208.44 751810 540520	Telephone		
	126.96 751820 540520	Telephone		
			CHECK 114534 TOTAL:	4,980.20
Invoice: 992789332x04112026	237.89 701224 540520	04/03/2026	042126	281.62
	43.73 701331 540520	WIRELESS SRV 3/4-4/3/26 ACT#992789332 Telephone		
			CHECK 114534 TOTAL:	4,980.20
114535 04/21/2026 PRTD 21426 BRIGHTVIEW LANDSCAPE SERVICES, IN 9619406	9619406	01/01/2026	042126	35,568.00
Invoice: 9619406	35,568.00 751810 678800	SPRAYFIELD & MAINT JANUARY 2026 District Sprayfield		
Invoice: 9649808	35,568.00 751810 678800	02/01/2026	042126	35,568.00
		SPRAYFIELD & MAINT FEBRUARY 2026 District Sprayfield		
Invoice: 9700846	35,568.00 751810 678800	03/01/2026	042126	35,568.00
		SPRAYFIELD & MAINT MARCH 2026 District Sprayfield		

A/P CASH DISBURSEMENTS JOURNAL

CASH ACCOUNT: 999 100100 Cash-General
 CHECK NO CHK DATE TYPE VENDOR NAME

CHECK NO	CHK DATE	TYPE	VENDOR NAME	INVOICE	INV DATE	PO	CHECK RUN	NET
					INVOICE DTL DESC			
							CHECK 114535 TOTAL:	106,704.00
114536	04/21/2026	PRTD	5405 CALOLYMPIC GLOVE SAFETY	3004519	03/31/2026	2260157	042126	1,013.69
			Invoice: 3004519					
				1,013.69	701	132000	RAINGEAR Storeroom & Truck Inventory	
							CHECK 114536 TOTAL:	1,013.69
114537	04/21/2026	PRTD	20655 CANNON CORPORATION	95642	04/13/2026		042126	9,247.25
			Invoice: 95642					
				9,247.25	301440	900000	TWIN LK, DARDENE, OAKRDG TANK REHAB MARCH 2026 Capital Asset Expenses	
			Invoice: 95645					
			CANNON CORPORATION	95645	04/13/2026		042126	9,084.00
				9,084.00	301440	900000	WILDLIFE CROSSING RELOCATION MARCH 2026 Capital Asset Expenses	
			Invoice: 95494					
			CANNON CORPORATION	95494	03/23/2026		042126	7,812.68
				7,812.68	301440	900000	P/R STATION NO. 32 REHAB FEBRUARY 2026 Capital Asset Expenses	
							CHECK 114537 TOTAL:	26,143.93
114538	04/21/2026	PRTD	16821 CLEAN SWEEP SUPPLY CO., INC	636996	04/06/2026	2260156	042126	2,630.71
			Invoice: 636996					
				2,630.71	701	132000	CLEANING CLOTHS Storeroom & Truck Inventory	
							CHECK 114538 TOTAL:	2,630.71
114539	04/21/2026	PRTD	30182 COMMERCIAL SCAFFOLDING OF CA, INC 10850-1F	10850-1F	03/17/2026		042126	4,000.00
			Invoice: 10850-1F					
				4,000.00	751820	551500	SCAFFOLDING SERVICES Outside Services	
							CHECK 114539 TOTAL:	4,000.00
114540	04/21/2026	PRTD	19270 COMMUNICATIONS RELAY, LLC	61940	04/01/2026		042126	1,140.76
			Invoice: 61940					
				1,140.76	701420	540520	CASTRO PEAK APRIL 2026 Telephone	
							CHECK 114540 TOTAL:	1,140.76
114541	04/21/2026	PRTD	15755 CORE & MAIN LP	Y745827	03/27/2026	2260172	042126	131.70
			Invoice: Y745827					
				131.70	701	132000	SCHRADER VALVES Storeroom & Truck Inventory	
			Invoice: Y804152					
			CORE & MAIN LP	Y804152	04/03/2026	2260172	042126	4,258.30
							SCHRADER VALVES	

A/P CASH DISBURSEMENTS JOURNAL

CASH ACCOUNT: 999 100100 Cash-General
 CHECK NO CHK DATE TYPE VENDOR NAME

CHECK NO	CHK DATE	TYPE	VENDOR NAME	INVOICE	INV DATE	PO	CHECK RUN	NET
							INVOICE DTL DESC	
				4,258.30 701	132000		Storeroom & Truck Inventory	
Invoice: Y761091			CORE & MAIN LP	Y761091	04/08/2026	2260171	042126	2,085.58
				2,085.58 701	132000		WAREHOUSE & YARD ITEMS Storeroom & Truck Inventory	
							CHECK 114541 TOTAL:	6,475.58
114542	04/21/2026	PRTD	19033 DENOVO VENTURES, LLC	94930	04/01/2026		042126	26,666.19
Invoice: 94930				26,666.19 701420	621500		CLOUD SRV/DIST RCVRY APRIL-JUNE 2026 System Support and Maintenance	
							CHECK 114542 TOTAL:	26,666.19
114543	04/21/2026	PRTD	30593 DION & SONS, INC	V225074	04/01/2026		042126	1,536.89
Invoice: V225074				1,536.89 751810	551000	165	GAL OIL - TAPIA Supplies/Material	
							CHECK 114543 TOTAL:	1,536.89
114544	04/21/2026	PRTD	7257 DIRECTV, INC.	017818825X260413	04/13/2026		042126	10.00
Invoice: 017818825X260413				10.00 751820	551500		TV ACCESS FEE 4/12-5/11/26 Outside Services	
Invoice: 015016309X260411			DIRECTV, INC.	015016309X260411	04/11/2026		042126	20.00
				20.00 701001	551500		TV ACCESS FEE 4/10-5/9/26 Outside Services	
							CHECK 114544 TOTAL:	30.00
114545	04/21/2026	PRTD	3515 OMEGA ENGINEERING, INC.	90188625	03/31/2026		042126	425.53
Invoice: 90188625				425.53 701526	572500		DIGITAL GAUGE FOR CALIBRATION Genl Supplies/Small Tools	
							CHECK 114545 TOTAL:	425.53
114546	04/21/2026	PRTD	30486 EIDE BAILLY LLP	EI02040650	04/09/2026		042126	30,000.00
Invoice: EI02040650				30,000.00 701410	652200		REGULATORY COMPLIANCE PROJECT Mgmt Consultant Fees	
							CHECK 114546 TOTAL:	30,000.00
114547	04/21/2026	PRTD	18441 EMPLOYEE RELATIONS NETWORK	100886	03/31/2026		042126	187.98
Invoice: 100886				187.98 701125	681000		EE BACKGROUND CHECKS Recruitment Expense	

A/P CASH DISBURSEMENTS JOURNAL

CASH ACCOUNT: 999 100100 Cash-General
 CHECK NO CHK DATE TYPE VENDOR NAME

CHECK NO	CHK DATE	TYPE	VENDOR NAME	INVOICE	INV DATE	PO	CHECK RUN	NET
INVOICE DTL DESC								
							CHECK 114547 TOTAL:	187.98
114548	04/21/2026	PRTD	30107 ENDRESS & HAUSER INC.	6002816972	03/24/2026	2260152	042126	6,768.55
			Invoice: 6002816972				RPLCMNT INSTRUMENT PROBES	
				6,768.55	751750	541000	Supplies	
							CHECK 114548 TOTAL:	6,768.55
114549	04/21/2026	PRTD	31067 EVERON, LLC	160730831	03/27/2026		042126	1,414.01
			Invoice: 160730831				INSTALLATION OF CELLULAR COMMUNICATOR- BLDG 7	
				1,414.01	701002	551500	Outside Services	
							CHECK 114549 TOTAL:	1,414.01
114550	04/21/2026	PRTD	2660 FISHER SCIENTIFIC	7566356	03/23/2026		042126	172.00
			Invoice: 7566356				TUBING	
				172.00	701341	551000	Supplies/Material	
			Invoice: 7860036				FISHER SCIENTIFIC	
				1,902.71	701341	551000	O & G EXTRACTION HEAD	
							Supplies/Material	
							CHECK 114550 TOTAL:	2,074.71
114551	04/21/2026	PRTD	30780 FLOW SCIENCE INCORPORATED	9738	04/03/2026		042126	5,000.00
			Invoice: 9738				HYDRODYNAMIC MDLNG/ANLYS MARCH 2026	
				5,000.00	754440	900000	Capital Asset Expenses	
							CHECK 114551 TOTAL:	5,000.00
114552	04/21/2026	PRTD	6770 G.I. INDUSTRIES	2590593-0283-8	04/01/2026		042126	3,839.22
			Invoice: 2590593-0283-8				25 YD ROLLOFF WLK MARCH 2026	
				3,839.22	101600	541500	Outside Services	
							CHECK 114552 TOTAL:	3,839.22
114553	04/21/2026	PRTD	30364 GEOTAB USA, INC.	IN482511	03/31/2026		042126	1,558.00
			Invoice: IN482511				PRO PLUS PLAN & SUPPORT MARCH 2026	
				1,558.00	701526	622500	Radio Maintenance Expense	
			Invoice: IN482510				GEOTAB USA, INC.	
				1,558.00	701526	622500	PRO PLUS PLAN & SUPPORT MARCH 2026	
							Radio Maintenance Expense	
			Invoice: CN211440				GEOTAB USA, INC.	
							CN211440	
							CR FOR INV#IN482510	-1,558.00

A/P CASH DISBURSEMENTS JOURNAL

CASH ACCOUNT: 999 100100 Cash-General
 CHECK NO CHK DATE TYPE VENDOR NAME

CHECK NO	CHK DATE	TYPE	VENDOR NAME	INVOICE	INV DATE	PO	CHECK RUN	NET
				INVOICE DTL DESC				
				783.29	751810	551500	Outside Services	
				783.29	101600	551500	Outside Services	
				783.29	130100	551500	Outside Services	
				783.29	101100	551500	Outside Services	
						CHECK	114559 TOTAL:	4,699.75
114560	04/21/2026	PRTD	31084 LEE & RO, INC	1287-01/04	04/13/2026		042126	10,142.50
						TAPIA EFFLUENT P/S REHAB MARCH 2026		
				10,142.50	754440	900000	Capital Asset Expenses	
						CHECK	114560 TOTAL:	10,142.50
114561	04/21/2026	PRTD	30556 MALLORY SAFETY & SUPPLY LLC	6387852	03/31/2026		042126	933.04
						CALIBRATION GAS FOR CONFINED SPACE METERS		
				933.04	751810	551000	Supplies/Material	
						CHECK	114561 TOTAL:	933.04
114562	04/21/2026	PRTD	30976 MOUSER ELECTRONICS, INC.	89698670	04/07/2026		042126	446.06
						CONTACT REPLACEMENT KIT		
				446.06	751810	551000	Supplies/Material	
						CHECK	114562 TOTAL:	446.06
114563	04/21/2026	PRTD	20736 NATIONWIDE	BD7900692571(26-27)	03/30/2026		042126	250.00
						SURETY BOND 5/27/26-5/26/27		
				250.00	701112	651600	Other Professional Serv	
						CHECK	114563 TOTAL:	250.00
114564	04/21/2026	PRTD	16754 NATURAL SURROUNDINGS	8935	04/01/2026		042126	375.00
						APRIL 2026 INTERIOR PLANT CARE		
				375.00	701001	551500	Outside Services	
						CHECK	114564 TOTAL:	375.00
114565	04/21/2026	PRTD	2302 ODP BUSINESS SOLUTIONS LLC	459746352001	04/01/2026		042126	59.05
						CERTIFICATE HOLDER		
				59.05	701125	681500	Empl Recognition Functions	
						PAPER		
						Forms, Supplies And Postage		
				217.26	701410	620000		217.26

A/P CASH DISBURSEMENTS JOURNAL

CASH ACCOUNT: 999 100100 Cash-General
 CHECK NO CHK DATE TYPE VENDOR NAME

CHECK NO	CHK DATE	TYPE	VENDOR NAME	INVOICE	INV DATE	PO	CHECK RUN	NET
					INVOICE DTL DESC			
							CHECK 114565 TOTAL:	276.31
114566	04/21/2026	PRTD	30269 PAPER RECYCLING & SHREDDING SPECI	625827	03/24/2026		042126	89.00
			Invoice: 625827		ON SITE DOC SHREDDING 3/24/26			
				89.00 701121 623500	Records Management			
			Invoice: 627044		04/07/2026		042126	89.00
					ON SITE DOC SHREDDING 4/7/26			
				89.00 701121 623500	Records Management			
							CHECK 114566 TOTAL:	178.00
114567	04/21/2026	PRTD	30621 RINGCENTRAL, INC.	CD_001401077	04/03/2026		042126	860.00
			Invoice: CD_001401077		CONTACT CENTER APRIL 2026			
				860.00 701420 621500	System Support and Maintenance			
							CHECK 114567 TOTAL:	860.00
114568	04/21/2026	PRTD	30284 ROGERS, ANDERSON, MALODY & SCOTT	80197	03/31/2026		042126	6,139.00
			Invoice: 80197		PROGRESS BILL SVCS THRU 3/31/26			
				6,139.00 701440 651700	Audit Fees			
							CHECK 114568 TOTAL:	6,139.00
114569	04/21/2026	PRTD	4586 ROYAL INDUSTRIAL SOLUTIONS	9009-1068083	04/02/2026		042126	620.09
			Invoice: 9009-1068083		20 AMP GFCI			
				620.09 751810 551000	Supplies/Material			
							CHECK 114569 TOTAL:	620.09
114570	04/21/2026	PRTD	20583 RT LAWRENCE CORPORATION	50663	04/07/2026		042126	616.67
			Invoice: 50663		LOCKBOX FEE MARCH 2026			
				616.67 701221 622000	Outside Services			
							CHECK 114570 TOTAL:	616.67
114571	04/21/2026	PRTD	2952 SHI INTERNATIONAL CORP	B21016827	04/02/2026	2260178	042126	2,376.70
			Invoice: B21016827		WIRELESS ACCESS POINT HRDWARE MAINT 4/1/26-3/31/29			
				2,376.70 701420 543000	Capital Outlay			
							CHECK 114571 TOTAL:	2,376.70
114572	04/21/2026	PRTD	30534 TAIT ENVIRONMENTAL SERVICES, INC.	970252	04/09/2026		042126	410.00
			Invoice: 970252		INSPECTION 3/4/26			
				410.00 701525 551500	Outside Services			

A/P CASH DISBURSEMENTS JOURNAL

CASH ACCOUNT: 999 100100 Cash-General
 CHECK NO CHK DATE TYPE VENDOR NAME

CHECK NO	CHK DATE	TYPE	VENDOR NAME	INVOICE	INV DATE	PO	CHECK RUN	NET
INVOICE DTL DESC								
							CHECK 114572 TOTAL:	410.00
114573	04/21/2026	PRTD	21599 THE ROVISYS COMPANY	110712	04/06/2026		042126	20,318.00
			Invoice: 110712					
				20,318.00	754440	900000	RLV SCADA UPGRD 2/1-3/31/26 Capital Asset Expenses	
			Invoice: 110755					
				101,666.28	301440	900000	04/06/2026 042126 UPGRD WTR BKHL & SCADA DESIGN MARCH 2026 Capital Asset Expenses	101,666.28
							CHECK 114573 TOTAL:	121,984.28
114574	04/21/2026	PRTD	31143 THE VALLEY ECONOMIC ALLIANCE	5798	03/30/2026		042126	2,500.00
			Invoice: 5798					
				2,500.00	701122	660410	VALLEY OF THE STARS SPONSORSHIP Professional Org Sponsorships	
							CHECK 114574 TOTAL:	2,500.00
114575	04/21/2026	PRTD	31043 TOTAL ACCESS ELEVATOR LLC	INV-09351-G5S6	04/01/2026		042126	290.00
			Invoice: INV-09351-G5S6					
				145.00	701001	551500	APRIL 2026 ELEVATOR SRV Outside Services	
				145.00	701002	551500	Outside Services	
							CHECK 114575 TOTAL:	290.00
114576	04/21/2026	PRTD	2325 UNITED RENTALS, INC	259266792-001	03/23/2026		042126	470.00
			Invoice: 259266792-001					
				470.00	701525	551500	PREVENTATIVE MAINT. HQ FORKLIFT #134 Outside Services	
							CHECK 114576 TOTAL:	470.00
114577	04/21/2026	PRTD	2780 VALLEY NEWS GROUP	4-2	04/03/2026		042126	250.00
			Invoice: 4-2					
				250.00	751840	660400	DISPLAY AD - FREE COMPOST 4/2/26 Public Education Programs	
							CHECK 114577 TOTAL:	250.00
114578	04/21/2026	PRTD	2701 GRAINGER	9846191782	03/18/2026		042126	425.23
			Invoice: 9846191782					
				425.23	701322	572500	IMPACT SOCKET & COMBINAITON WRENCH Genl Supplies/Small Tools	
			Invoice: 9847744928					
				296.28	101900	572500	03/19/2026 042126 FLANGE GASKET Genl Supplies/Small Tools	296.28

A/P CASH DISBURSEMENTS JOURNAL

CASH ACCOUNT: 999 100100 Cash-General
 CHECK NO CHK DATE TYPE VENDOR NAME

CHECK NO	CHK DATE	TYPE	VENDOR NAME	INVOICE	INV DATE	PO	CHECK RUN	NET
				INVOICE DTL DESC				
Invoice: 9852191627			GRAINGER	9852191627	03/23/2026		042126	907.74
				907.74 101900 572500	WAREHOUSE SUPPLIES Genl Supplies/Small Tools			
Invoice: 9852191635			GRAINGER	9852191635	03/23/2026		042126	370.36
				370.36 101900 572500	FLANGE GASKET Genl Supplies/Small Tools			
Invoice: 9853596766			GRAINGER	9853596766	03/24/2026		042126	351.53
				351.53 101900 572500	FLANGE GASKET Genl Supplies/Small Tools			
Invoice: 9854177962			GRAINGER	9854177962	03/25/2026		042126	130.49
				130.49 101100 551000	FLANGE GASKET Supplies/Material			
Invoice: 9855506920			GRAINGER	9855506920	03/25/2026		042126	54.71
				54.71 701001 551000	REPAIR CLAMP Supplies/Material			
							CHECK 114578 TOTAL:	2,536.34
114579	04/21/2026	PRTD	30823 WALSH CONSTRUCTION COMPANY II, LL 10635/PMT#23	10635/PMT#23	04/08/2026		042126	909,559.26
			Invoice: 10635/PMT#23	909,559.26 754440 900000	PHASE 1 DESIGN BUILD SVCS PWP MARCH 2026 Capital Asset Expenses			
							CHECK 114579 TOTAL:	909,559.26
				NUMBER OF CHECKS	67	*** CASH ACCOUNT TOTAL ***		1,634,252.97
				TOTAL PRINTED CHECKS	COUNT	AMOUNT		
				TOTAL EFT'S	57	1,433,067.08		
					10	201,185.89		
							*** GRAND TOTAL ***	1,634,252.97

A/P CASH DISBURSEMENTS JOURNAL

JOURNAL ENTRIES TO BE CREATED

CLERK: 3296tchau

YEAR	PER	JNL	SRC	ACCOUNT	JNL	DESC	REF 1	REF 2	REF 3	ACCOUNT	DESC	T	OB	DEBIT	CREDIT
			EFF	DATE						LINE	DESC				
2026	10	264													
APP	701-200000		04/21/2026	042126	042126					Accounts Payable				227,686.30	
										AP CASH DISBURSEMENTS JOURNAL					
APP	999-100100		04/21/2026	042126	042126					Cash-General					1,634,252.97
										AP CASH DISBURSEMENTS JOURNAL					
APP	751-200000		04/21/2026	042126	042126					Accounts Payable				134,248.30	
										AP CASH DISBURSEMENTS JOURNAL					
APP	101-200000		04/21/2026	042126	042126					Accounts Payable				116,768.44	
										AP CASH DISBURSEMENTS JOURNAL					
APP	301-200000		04/21/2026	042126	042126					Accounts Payable				208,822.88	
										AP CASH DISBURSEMENTS JOURNAL					
APP	754-200000		04/21/2026	042126	042126					Accounts Payable				945,943.76	
										AP CASH DISBURSEMENTS JOURNAL					
APP	130-200000		04/21/2026	042126	042126					Accounts Payable				783.29	
										AP CASH DISBURSEMENTS JOURNAL					
										GENERAL LEDGER TOTAL				1,634,252.97	1,634,252.97
APP	999-207010		04/21/2026	042126	042126					Due to/Due FromInternal Svcs				227,686.30	
										Cash-General					227,686.30
APP	701-100100		04/21/2026	042126	042126					Due to/Due FromJPA Operations				134,248.30	
										Cash-General					134,248.30
APP	999-207510		04/21/2026	042126	042126					Due to/Due Frm Potable Wtr Ops				116,768.44	
										Cash-General					116,768.44
APP	751-100100		04/21/2026	042126	042126					Due to/Due FrmPotable Wtr Repl				208,822.88	
										Cash-General					208,822.88
APP	999-203010		04/21/2026	042126	042126					Due to/Due FromJPA Replacement				945,943.76	
										Cash-General					945,943.76
APP	301-100100		04/21/2026	042126	042126					Due to/Due FrmSanitation Ops				783.29	
										Cash-General					783.29
APP	999-207540		04/21/2026	042126	042126					SYSTEM GENERATED ENTRIES TOTAL				1,634,252.97	1,634,252.97
										JOURNAL 2026/10/264 TOTAL				3,268,505.94	3,268,505.94

A/P CASH DISBURSEMENTS JOURNAL
 JOURNAL ENTRIES TO BE CREATED

FUND ACCOUNT	YEAR PER	JNL	EFF DATE	ACCOUNT DESCRIPTION	DEBIT	CREDIT
101 Potable Water Operations 101-100100 101-200000	2026 10	264	04/21/2026	Cash-General Accounts Payable	116,768.44	116,768.44
				FUND TOTAL	116,768.44	116,768.44
130 Sanitation Operations 130-100100 130-200000	2026 10	264	04/21/2026	Cash-General Accounts Payable	783.29	783.29
				FUND TOTAL	783.29	783.29
301 Potable wtr Replacement Fund 301-100100 301-200000	2026 10	264	04/21/2026	Cash-General Accounts Payable	208,822.88	208,822.88
				FUND TOTAL	208,822.88	208,822.88
701 Internal Service Fund 701-100100 701-200000	2026 10	264	04/21/2026	Cash-General Accounts Payable	227,686.30	227,686.30
				FUND TOTAL	227,686.30	227,686.30
751 JPA Operations 751-100100 751-200000	2026 10	264	04/21/2026	Cash-General Accounts Payable	134,248.30	134,248.30
				FUND TOTAL	134,248.30	134,248.30
754 JPA Replacement 754-100100 754-200000	2026 10	264	04/21/2026	Cash-General Accounts Payable	945,943.76	945,943.76
				FUND TOTAL	945,943.76	945,943.76
999 Pooled Cash 999-100100 999-201010 999-201300 999-203010 999-207010 999-207510 999-207540	2026 10	264	04/21/2026	Cash-General Due to/Due Frm Potable Wtr Ops Due to/Due Frm Sanitation Ops Due to/Due Frm Potable wtr Repl Due to/Due From Internal Svs Due to/Due From JPA Operations Due to/Due From JPA Replacement	116,768.44 783.29 208,822.88 227,686.30 134,248.30 945,943.76	1,634,252.97
				FUND TOTAL	1,634,252.97	1,634,252.97

A/P CASH DISBURSEMENTS JOURNAL
 JOURNAL ENTRIES TO BE CREATED

FUND		DUE TO	DUE FR
101	Potable Water Operations		116,768.44
130	Sanitation Operations		783.29
301	Potable Wtr Replacement Fund		208,822.88
701	Internal Service Fund		227,686.30
751	JPA Operations		134,248.30
754	JPA Replacement		945,943.76
999	Pooled Cash		
		1,634,252.97	
TOTAL		1,634,252.97	1,634,252.97

** END OF REPORT - Generated by Thieu Chau **

A/P CASH DISBURSEMENTS JOURNAL

JOURNAL ENTRIES TO BE CREATED

CLERK: 3296jcortez

YEAR	PER	JNL	SRC	ACCOUNT	EFF DATE	JNL	DESC	REF 1	REF 2	REF 3	ACCOUNT	DESC	T	OB	DEBIT	CREDIT
2026	9	511	APP	751-200000	03/31/2026	1095		033126			Accounts Payable					1,816.36
											AP CASH DISBURSEMENTS JOURNAL					
			APP	999-100100	03/31/2026	1095		033126			Cash-General			1,702.22		
											AP CASH DISBURSEMENTS JOURNAL					
			APP	101-200000	03/31/2026	1130		033126			Accounts Payable					338.03
											AP CASH DISBURSEMENTS JOURNAL					
			APP	999-100100	03/31/2026	1130		033126			Cash-General			338.03		
											AP CASH DISBURSEMENTS JOURNAL					
			APP	999-100100	03/31/2026	1141		033126			Cash-General			114.14		
											AP CASH DISBURSEMENTS JOURNAL					
											GENERAL LEDGER TOTAL			2,154.39	2,154.39	
			APP	999-207510	03/31/2026	030326		033126			Due to/Due FromJPA Operations					1,816.36
											Cash-General			1,816.36		
			APP	999-201010	03/31/2026	030326		033126			Due to/Due Frm Potable Wtr Ops					338.03
											Cash-General			338.03		
			APP	101-100100	03/31/2026	030326		033126								
											SYSTEM GENERATED ENTRIES TOTAL			2,154.39	2,154.39	
											JOURNAL 2026/09/511	TOTAL			4,308.78	4,308.78

A/P CASH DISBURSEMENTS JOURNAL
 JOURNAL ENTRIES TO BE CREATED

FUND ACCOUNT	YEAR PER	JNL	EFF DATE	ACCOUNT DESCRIPTION	DEBIT	CREDIT
101 Potable Water Operations 101-100100 101-200000	2026 9	511	03/31/2026	Cash-General	338.03	
				Accounts Payable		338.03
				FUND TOTAL	338.03	338.03
751 JPA Operations 751-100100 751-200000	2026 9	511	03/31/2026	Cash-General	1,816.36	
				Accounts Payable		1,816.36
				FUND TOTAL	1,816.36	1,816.36
999 Pooled Cash 999-100100 999-201010 999-207510	2026 9	511	03/31/2026	Cash-General	2,154.39	
				Due to/Due Frm Potable Wtr Ops		338.03
				Due to/Due FromJPA Operations		1,816.36
				FUND TOTAL	2,154.39	2,154.39

A/P CASH DISBURSEMENTS JOURNAL
JOURNAL ENTRIES TO BE CREATED

FUND		DUE TO	DUE FR
101	Potable Water Operations		338.03
751	JPA Operations		1,816.36
999	Pooled Cash		
	TOTAL	2,154.39	2,154.39

** END OF REPORT - Generated by Jessica Cortez **

A/P CASH DISBURSEMENTS JOURNAL

CASH ACCOUNT: 999 100100 Cash-General
 CHECK NO CHK DATE TYPE VENDOR NAME

CHECK NO	CHK DATE	TYPE	VENDOR NAME	INVOICE	INV DATE	PO	CHECK RUN	NET
1077	02/17/2026	VOID	30619 LLOYD'S PLUMBING, INC.	202634630	01/05/2026			-906.69
			Invoice: 202634630					
				-906.69	751820	551500		
							CLEAR DRAIN LINE 1/5/26 Outside Services	
							CHECK 1077 TOTAL:	-906.69
				NUMBER OF CHECKS	1		*** CASH ACCOUNT TOTAL ***	-906.69
				TOTAL VOIDED CHECKS		COUNT	AMOUNT	
						1	906.69	
							*** GRAND TOTAL ***	-906.69

A/P CASH DISBURSEMENTS JOURNAL

JOURNAL ENTRIES TO BE CREATED

CLERK: 3296jcortez

YEAR	PER	JNL	SRC	ACCOUNT	JNL	DESC	REF 1	REF 2	REF 3	ACCOUNT	DESC	T	OB	DEBIT	CREDIT
					EFF	DATE				LINE	DESC				
2026	9	518													
APP	751-200000				03/31/2026	1077	033126			Accounts Payable					906.69
APP	999-100100				03/31/2026	1077	033126			AP CASH DISBURSEMENTS JOURNAL				906.69	
										Cash-General					
										AP CASH DISBURSEMENTS JOURNAL					
										GENERAL LEDGER TOTAL				906.69	906.69
APP	999-207510				03/31/2026	021726	033126			Due to/Due FromJPA Operations					906.69
APP	751-100100				03/31/2026	021726	033126			Cash-General				906.69	
										SYSTEM GENERATED ENTRIES TOTAL				906.69	906.69
										JOURNAL 2026/09/518				1,813.38	1,813.38
										TOTAL					

A/P CASH DISBURSEMENTS JOURNAL
 JOURNAL ENTRIES TO BE CREATED

FUND	ACCOUNT	YEAR	PER	JNL	EFF DATE	ACCOUNT DESCRIPTION	DEBIT	CREDIT
751	JPA Operations	2026	9	518	03/31/2026			
	751-100100					Cash-General	906.69	
	751-200000					Accounts Payable		906.69
						FUND TOTAL	906.69	906.69
999	Pooled Cash	2026	9	518	03/31/2026			
	999-100100					Cash-General	906.69	
	999-207510					Due to/Due From JPA Operations		906.69
						FUND TOTAL	906.69	906.69

A/P CASH DISBURSEMENTS JOURNAL
JOURNAL ENTRIES TO BE CREATED

FUND		DUE TO	DUE FR
751	JPA Operations		906.69
999	Pooled Cash	906.69	
	TOTAL	906.69	906.69

** END OF REPORT - Generated by Jessica Cortez **

A/P CASH DISBURSEMENTS JOURNAL

CASH ACCOUNT: 999 100100 Cash-General
 CHECK NO CHK DATE TYPE VENDOR NAME

CHECK NO	CHK DATE	TYPE	VENDOR NAME	INVOICE	INV DATE	PO	CHECK RUN	NET	
26209	03/31/2026	MANL	3352 LAS VIRGENES MUNICIPAL WATER DIST	5676784	03/16/2026		041426A	58.79	
				Invoice: 5676784	SOLAR LANDSCAPING 2/5-3/5/26				
				58.79 751820 540540	Water				
							CHECK	26209 TOTAL:	58.79
26217	04/14/2026	MANL	3352 LAS VIRGENES MUNICIPAL WATER DIST	5682768	03/31/2026		041426A	251.80	
				Invoice: 5682768	RWPS 2/20-3/20/26				
				251.80 701001 540540	Water				
							CHECK	26217 TOTAL:	251.80
26218	04/14/2026	MANL	3352 LAS VIRGENES MUNICIPAL WATER DIST	5682773	03/31/2026		041426A	306.78	
				Invoice: 5682773	BD#8/RW 2/20-3/20/26				
				306.78 701001 540540	Water				
							CHECK	26218 TOTAL:	306.78
26219	04/14/2026	MANL	3352 LAS VIRGENES MUNICIPAL WATER DIST	5682775	03/31/2026		041426A	270.77	
				Invoice: 5682775	HQ BD#8/RW 2/20-3/20/26				
				270.77 701001 540540	Water				
							CHECK	26219 TOTAL:	270.77
26220	04/14/2026	MANL	3352 LAS VIRGENES MUNICIPAL WATER DIST	5682778	03/31/2026		041426A	296.89	
				Invoice: 5682778	BD#7/RW 2/20-3/20/26				
				296.89 701002 540540	Water				
							CHECK	26220 TOTAL:	296.89
26221	04/14/2026	MANL	3352 LAS VIRGENES MUNICIPAL WATER DIST	5683174	03/31/2026		041426A	46.73	
				Invoice: 5683174	IND HILLS 2/20-3/20/26				
				46.73 751223 540540	Water				
							CHECK	26221 TOTAL:	46.73
26222	04/14/2026	MANL	3352 LAS VIRGENES MUNICIPAL WATER DIST	5683600	03/31/2026		041426A	46.73	
				Invoice: 5683600	MORRSN P/S 2/20-3/20/26				
				46.73 751125 540540	Water				
							CHECK	26222 TOTAL:	46.73
26223	04/14/2026	MANL	3352 LAS VIRGENES MUNICIPAL WATER DIST	5690066	03/31/2026		041426A	91.88	
				Invoice: 5690066	EQS TANK 2/20-3/20/26				
				91.88 101201 540540	Water				

A/P CASH DISBURSEMENTS JOURNAL

CASH ACCOUNT: 999 100100 Cash-General
 CHECK NO CHK DATE TYPE VENDOR NAME

CHECK NO	CHK DATE	TYPE	VENDOR NAME	INVOICE	INV DATE	PO	CHECK RUN	NET
INVOICE DTL DESC								
							CHECK 26223 TOTAL:	91.88
26224	04/14/2026	MANL	3352 LAS VIRGENES MUNICIPAL WATER DIST	5690323	03/31/2026		041426A	54.72
			Invoice: 5690323			WLK FLT PLANT 2/20-3/20/26		
				54.72 101600 540540		Water		
							CHECK 26224 TOTAL:	54.72
26225	04/14/2026	MANL	3352 LAS VIRGENES MUNICIPAL WATER DIST	5690328	03/31/2026		041426A	625.23
			Invoice: 5690328			WLK FLT PLANT 2/20-3/20/26		
				625.23 101600 540540		Water		
							CHECK 26225 TOTAL:	625.23
26226	04/14/2026	MANL	30658 WELLS FARGO BANK	MARCH 2026	04/08/2026		041426A	2,046.57
			Invoice: MARCH 2026			WFB CLIENT ANALYSIS FEE MARCH 2026		
				2,046.57 101001 862500		Other Non-Operating Expense		
							CHECK 26226 TOTAL:	2,046.57
				NUMBER OF CHECKS	11		*** CASH ACCOUNT TOTAL ***	4,096.89
				TOTAL MANUAL CHECKS		COUNT	AMOUNT	
						11	4,096.89	
							*** GRAND TOTAL ***	4,096.89

A/P CASH DISBURSEMENTS JOURNAL

JOURNAL ENTRIES TO BE CREATED

CLERK: 3296tchau

YEAR PER	JNL	SRC ACCOUNT	EFF DATE	JNL DESC	REF 1	REF 2	REF 3	ACCOUNT DESC LINE DESC	T OB	DEBIT	CREDIT
2026 10	190	APP 751-200000	04/14/2026	041426A	041426			Accounts Payable		152.25	
		APP 999-100100	04/14/2026	041426A	041426			AP CASH DISBURSEMENTS JOURNAL Cash-General			4,096.89
		APP 701-200000	04/14/2026	041426A	041426			Accounts Payable		1,126.24	
		APP 101-200000	04/14/2026	041426A	041426			AP CASH DISBURSEMENTS JOURNAL Accounts Payable		2,818.40	
			04/14/2026	041426A	041426			AP CASH DISBURSEMENTS JOURNAL GENERAL LEDGER TOTAL		4,096.89	4,096.89
		APP 999-207510	04/14/2026	041426A	041426			Due to/Due FromJPA Operations		152.25	
		APP 751-100100	04/14/2026	041426A	041426			Cash-General			152.25
		APP 999-207010	04/14/2026	041426A	041426			Due to/Due FromInternal Svs		1,126.24	
		APP 701-100100	04/14/2026	041426A	041426			Cash-General			1,126.24
		APP 999-201010	04/14/2026	041426A	041426			Due to/Due Frm Potable Wtr Ops		2,818.40	
		APP 101-100100	04/14/2026	041426A	041426			Cash-General			2,818.40
								SYSTEM GENERATED ENTRIES TOTAL		4,096.89	4,096.89
								JOURNAL 2026/10/190 TOTAL		8,193.78	8,193.78

A/P CASH DISBURSEMENTS JOURNAL
JOURNAL ENTRIES TO BE CREATED

FUND ACCOUNT	YEAR PER	JNL	EFF DATE	ACCOUNT DESCRIPTION	DEBIT	CREDIT
101 Potable Water Operations 101-100100 101-200000	2026 10	190	04/14/2026	Cash-General		2,818.40
				Accounts Payable	2,818.40	
				FUND TOTAL	2,818.40	2,818.40
701 Internal Service Fund 701-100100 701-200000	2026 10	190	04/14/2026	Cash-General		1,126.24
				Accounts Payable	1,126.24	
				FUND TOTAL	1,126.24	1,126.24
751 JPA Operations 751-100100 751-200000	2026 10	190	04/14/2026	Cash-General		152.25
				Accounts Payable	152.25	
				FUND TOTAL	152.25	152.25
999 Pooled Cash 999-100100 999-201010 999-207010 999-207510	2026 10	190	04/14/2026	Cash-General		4,096.89
				Due to/Due Frm Potable Wtr Ops	2,818.40	
				Due to/Due FromInternal Sys	1,126.24	
				Due to/Due FromJPA Operations	152.25	
				FUND TOTAL	4,096.89	4,096.89

A/P CASH DISBURSEMENTS JOURNAL
JOURNAL ENTRIES TO BE CREATED

FUND		DUE TO	DUE FR
101	Potable Water Operations		2,818.40
701	Internal Service Fund		1,126.24
751	JPA Operations		152.25
999	Pooled Cash		
	TOTAL	4,096.89	4,096.89

** END OF REPORT - Generated by Thieu Chau **

A/P CASH DISBURSEMENTS JOURNAL

CASH ACCOUNT: 999 100100 Cash-General
 CHECK NO CHK DATE TYPE VENDOR NAME

			INVOICE	INV DATE	PO	CHECK RUN	NET	
			INVOICE DTL DESC					
26227	04/21/2026	MANL 30658	WELLS FARGO BANK	10001/MARCH	2026	04/01/2026	042126A	56,242.35
Invoice: 10001/MARCH 2026			VISA CHARGES MARCH 2026					
			7.00 701121	683000		Training & Professional Devel		
			32.94 701121	683000		Training & Professional Devel		
			41.32 701112	601000		Directors' Conference Exp		
			52.55 701121	711000		Misc Staff Expense		
			104.80 701121	711000		Misc Staff Expense		
			151.36 701121	711000		Misc Staff Expense		
			422.80 701121	683000		Training & Professional Devel		
			-465.00 701410	683000		Training & Professional Devel		
			-420.03 701410	683000		Training & Professional Devel		
			-91.72 701230	660400		Public Education Programs		
			-72.42 701230	660400		Public Education Programs		
			.59 701525	551000		Supplies/Material		
			.96 701525	552000		Permits and Fees		
			.96 701525	552000		Permits and Fees		
			1.50 701112	601000		Directors' Conference Exp		
			1.63 701001	551000		Supplies/Material		
			2.00 701112	601000		Directors' Conference Exp		
			2.20 701121	683000		Training & Professional Devel		
			2.36 701420	621500		System Support and Maintenance		
			2.65 701121	711000		Misc Staff Expense		
			3.00 701121	683000		Training & Professional Devel		
			3.47 701210	620000		Forms, Supplies And Postage		
			5.00 701121	683000		Training & Professional Devel		
			5.60 701121	683000		Training & Professional Devel		
			8.40 701112	601000		Directors' Conference Exp		
			8.69 701121	620000		Forms, Supplies And Postage		
			8.77 101600	551000		Supplies/Material		
			8.85 701112	601500		Directors' Miscellaneous		
			9.86 701525	551010		Fuel		
			10.00 701121	683000		Training & Professional Devel		
			10.42 701521	551000		Supplies/Material		
			11.59 701525	551010		Fuel		
			13.15 751810	541000		Supplies/Material		
			14.23 101700	551000		Supplies/Material		
			14.79 701310	711000		Misc Staff Expense		
			15.00 701230	710500		Dues, Subsc & Memberships		
			15.00 701121	683000		Training & Professional Devel		
			15.50 701121	683000		Training & Professional Devel		
			16.00 701121	683000		Training & Professional Devel		
			17.00 701525	551500		Outside Services		
			18.99 701230	683000		Training & Professional Devel		
			19.34 751840	620000		Forms, Supplies And Postage		
			19.73 751810	551000		Supplies/Material		
			20.00 701530	683000		Training & Professional Devel		
			21.38 701521	683000		Training & Professional Devel		
			21.38 701521	683000		Training & Professional Devel		
			21.93 101100	551000		Supplies/Material		
			22.25 701121	683000		Training & Professional Devel		
			22.76 701121	683000		Training & Professional Devel		
			22.99 701112	601000		Directors' Conference Exp		

A/P CASH DISBURSEMENTS JOURNAL

CASH ACCOUNT: 999 100100 Cash-General
 CHECK NO CHK DATE TYPE VENDOR NAME

INVOICE	INV DATE	PO	CHECK RUN	NET
INVOICE DTL DESC				
24.00 701121	683000			Training & Professional Devel
24.00 701112	601000			Directors' Conference Exp
24.12 701310	711000			Misc Staff Expense
24.22 701222	572500			Genl Supplies/Small Tools
25.23 101700	551000			Supplies/Material
25.50 701121	711000			Misc Staff Expense
26.47 101600	541000			Supplies/Material
26.83 751820	551000			Supplies/Material
27.43 701002	551000			Supplies/Material
27.74 701121	683000			Training & Professional Devel
28.00 701525	551000			Supplies/Material
28.00 701210	683000			Training & Professional Devel
30.80 701121	683000			Training & Professional Devel
30.80 701121	683000			Training & Professional Devel
30.80 701230	683000			Training & Professional Devel
30.80 701310	683000			Training & Professional Devel
30.80 701310	683000			Training & Professional Devel
30.80 701310	683000			Training & Professional Devel
30.80 701530	683000			Training & Professional Devel
30.80 701530	683000			Training & Professional Devel
32.13 701525	551000			Supplies/Material
32.13 701525	551000			Supplies/Material
32.18 751810	678800			District Sprayfield
35.00 701440	683000			Training & Professional Devel
37.92 701121	683000			Training & Professional Devel
38.99 701121	683000			Training & Professional Devel
38.99 701121	710500			Dues, Subsc & Memberships
39.87 101100	541000			Supplies/Material
40.00 751840	620000			Forms, Supplies And Postage
43.39 701521	683000			Training & Professional Devel
43.83 751810	551000			Supplies/Material
44.00 701112	601000			Directors' Conference Exp
44.03 701521	683000			Training & Professional Devel
44.68 751840	620000			Forms, Supplies And Postage
45.00 701531	683000			Training & Professional Devel
45.00 701531	683000			Training & Professional Devel
45.10 701112	601000			Directors' Conference Exp
46.11 701121	711000			Misc Staff Expense
48.34 701343	711000			Misc Staff Expense
50.00 701341	683000			Training & Professional Devel
50.00 701230	683000			Training & Professional Devel
51.97 701121	683000			Training & Professional Devel
52.78 701521	683000			Training & Professional Devel
54.60 701521	683000			Training & Professional Devel
55.98 701125	681500			Empl Recognition Functions
59.23 701210	711000			Misc Staff Expense
60.00 701121	711000			Misc Staff Expense
63.61 751820	541000			Supplies/Material
63.70 701322	711000			Misc Staff Expense
64.34 701210	711000			Misc Staff Expense
65.00 701112	601000			Directors' Conference Exp
65.04 701525	551010			Fuel
65.83 751750	541000			Supplies

A/P CASH DISBURSEMENTS JOURNAL

CASH ACCOUNT: 999 100100 Cash-General
 CHECK NO CHK DATE TYPE VENDOR NAME

INVOICE	INV DATE	PO	CHECK RUN	NET
INVOICE DTL DESC				
66.65 701322	711000			Misc Staff Expense
70.74 751810	678800			District Sprayfield
72.62 701521	711000			Misc Staff Expense
73.98 751810	541000			Supplies/Material
75.00 701531	683000			Training & Professional Devel
75.38 701510	711000			Misc Staff Expense
76.72 701230	660400			Public Education Programs
76.80 701002	551000			Supplies/Material
76.94 751820	551000			Supplies/Material
77.98 701121	683000			Training & Professional Devel
79.98 701230	660400			Public Education Programs
80.00 701310	710500			Dues, Subsc & Memberships
80.14 701525	551010			Fuel
81.90 701121	620000			Forms, Supplies And Postage
84.89 751810	678800			District Sprayfield
90.00 701341	683000			Training & Professional Devel
94.39 701310	711000			Misc Staff Expense
96.64 701525	551010			Fuel
102.51 101700	551000			Supplies/Material
117.30 751810	541000			Supplies/Material
118.93 751810	551000			Supplies/Material
119.00 701222	710500			Dues, Subsc & Memberships
124.94 751820	551000			Supplies/Material
125.00 701112	601000			Directors' Conference Exp
125.05 751810	678800			District Sprayfield
130.00 701001	551000			Supplies/Material
137.40 701530	683000			Training & Professional Devel
141.67 751820	551000			Supplies/Material
148.17 701001	551000			Supplies/Material
148.50 701440	711000			Misc Staff Expense
149.00 701331	683000			Training & Professional Devel
149.13 701521	551000			Supplies/Material
150.00 701121	683000			Training & Professional Devel
151.00 701230	660400			Public Education Programs
154.00 701420	710500			Dues, Subsc & Memberships
163.53 101700	551000			Supplies/Material
164.14 701230	660400			Public Education Programs
177.80 701525	551500			Outside Services
177.80 701525	551500			Outside Services
177.80 701525	551500			Outside Services
177.80 701525	551500			Outside Services
195.00 701420	540520			Telephone
200.00 701125	681000			Recruitment Expense
200.00 701220	683000			Training & Professional Devel
203.40 701121	683000			Training & Professional Devel
203.40 701121	683000			Training & Professional Devel
206.90 701526	572500			genl Supplies/Small Tools
210.46 751810	551000			Supplies/Material
210.48 701525	551000			Supplies/Material
216.02 101100	541000			Supplies/Material
219.45 701521	551000			Supplies/Material
236.96 701440	683000			Training & Professional Devel

A/P CASH DISBURSEMENTS JOURNAL

CASH ACCOUNT: 999 100100 Cash-General
 CHECK NO CHK DATE TYPE VENDOR NAME

		INVOICE	INV DATE	PO	CHECK RUN	NET
		INVOICE DTL DESC				
	236.96	701440	683000		Training & Professional Devel	
	239.00	701340	683000		Training & Professional Devel	
	240.00	701420	621500		System Support and Maintenance	
	240.00	701340	710500		Dues, Subsc & Memberships	
	244.60	751820	551000		Supplies/Material	
	245.00	751810	678800		District Sprayfield	
	250.00	701526	683000		Training & Professional Devel	
	251.53	701331	551000		Supplies/Material	
	263.03	101600	541000		Supplies/Material	
	267.96	701526	572500		Genl Supplies/Small Tools	
	270.22	751810	551000		Supplies/Material	
	282.00	101700	541500		Outside Services	
	283.13	701230	620000		Forms, Supplies And Postage	
	286.47	701230	683000		Training & Professional Devel	
	306.29	701226	572500		Genl Supplies/Small Tools	
	309.00	701222	572500		Genl Supplies/Small Tools	
	321.46	701125	682500		Empl wellness Program	
	325.00	701125	681000		Recruitment Expense	
	340.00	701410	710500		Dues, Subsc & Memberships	
	349.40	701530	683000		Training & Professional Devel	
	356.95	701525	551000		Supplies/Material	
	370.89	101700	551000		Supplies/Material	
	375.00	701521	710500		Dues, Subsc & Memberships	
	383.03	701521	551000		Supplies/Material	
	384.11	101700	551000		Supplies/Material	
	425.00	701230	710500		Dues, Subsc & Memberships	
	425.00	701530	683000		Training & Professional Devel	
	425.88	701530	683000		Training & Professional Devel	
	434.00	751840	660600		Community Group Outreach	
	439.35	101700	551000		Supplies/Material	
	468.00	701125	710500		Dues, Subsc & Memberships	
	468.98	701521	683000		Training & Professional Devel	
	468.98	701521	683000		Training & Professional Devel	
	472.04	751820	551000		Supplies/Material	
	500.00	701410	710500		Dues, Subsc & Memberships	
	532.80	701210	683000		Training & Professional Devel	
	544.07	101200	541000		Supplies/Material	
	552.80	701112	601000		Directors' Conference Exp	
	557.65	701222	572500		Genl Supplies/Small Tools	
	568.22	701125	683000		Training & Professional Devel	
	600.00	701230	660600		Community Group Outreach	
	608.00	701525	551000		Supplies/Material	
	634.14	701001	551000		Supplies/Material	
	645.00	701112	601000		Directors' Conference Exp	
	686.80	701332	683000		Training & Professional Devel	
	750.00	701332	683000		Training & Professional Devel	
	766.03	701526	572500		genl Supplies/Small Tools	
	779.01	701121	683000		Training & Professional Devel	
	786.84	701525	551000		Supplies/Material	
	798.70	701230	660400		Public Education Programs	
	800.00	701122	715500		Other Expense	
	810.00	701112	601000		Directors' Conference Exp	

A/P CASH DISBURSEMENTS JOURNAL

CASH ACCOUNT: 999 100100 Cash-General
 CHECK NO CHK DATE TYPE VENDOR NAME

INVOICE	INV DATE	PO	CHECK RUN	NET
INVOICE DTL DESC				
826.67 701420 543000				
875.00 701112 601000				
875.00 701112 601000				
875.00 701112 601000				
875.00 701112 601000				
911.59 751810 678800				
928.38 701410 683000				
941.73 701440 683000				
999.00 701230 683000				
1,000.00 701230 683000				
1,161.09 701112 601000				
1,206.09 701112 601000				
1,209.11 101100 551000				
1,245.42 701112 601000				
1,245.42 701112 601000				
1,400.00 701121 683000				
1,635.24 701525 551000				
1,958.00 701525 551000				
2,598.75 751810 551500				
272.91 701525 551500				
441.91 701525 551500				
			CHECK 26227 TOTAL:	56,242.35
NUMBER OF CHECKS	1	*** CASH ACCOUNT TOTAL ***		56,242.35
TOTAL MANUAL CHECKS	COUNT	AMOUNT		
	1	56,242.35		
		*** GRAND TOTAL ***		56,242.35

A/P CASH DISBURSEMENTS JOURNAL

JOURNAL ENTRIES TO BE CREATED

CLERK: 3296tchau

YEAR PER	JNL	SRC ACCOUNT	JNL DATE	JNL DESC	REF 1	REF 2	REF 3	ACCOUNT DESC LINE DESC	T OB	DEBIT	CREDIT
2026	10	265									
APP	701-200000		04/21/2026	042126A	042126			Accounts Payable AP CASH DISBURSEMENTS JOURNAL		45,440.95	
APP	999-100100		04/21/2026	042126A	042126			Cash-General AP CASH DISBURSEMENTS JOURNAL			56,242.35
APP	101-200000		04/21/2026	042126A	042126			Accounts Payable AP CASH DISBURSEMENTS JOURNAL		4,111.12	
APP	751-200000		04/21/2026	042126A	042126			Accounts Payable AP CASH DISBURSEMENTS JOURNAL		6,690.28	
								GENERAL LEDGER TOTAL		56,242.35	56,242.35
APP	999-207010		04/21/2026	042126A	042126			Due to/Due FromInternal Svcs		45,440.95	
APP	701-100100		04/21/2026	042126A	042126			Cash-General			45,440.95
APP	999-201010		04/21/2026	042126A	042126			Due to/Due Frm Potable Wtr Ops		4,111.12	
APP	101-100100		04/21/2026	042126A	042126			Cash-General			4,111.12
APP	999-207510		04/21/2026	042126A	042126			Due to/Due FromJPA Operations		6,690.28	
APP	751-100100		04/21/2026	042126A	042126			Cash-General			6,690.28
								SYSTEM GENERATED ENTRIES TOTAL		56,242.35	56,242.35
								JOURNAL 2026/10/265 TOTAL		112,484.70	112,484.70

A/P CASH DISBURSEMENTS JOURNAL
JOURNAL ENTRIES TO BE CREATED

FUND ACCOUNT	YEAR PER	JNL	EFF DATE	ACCOUNT DESCRIPTION	DEBIT	CREDIT
101 Potable Water Operations 101-100100 101-200000	2026 10	265	04/21/2026	Cash-General		4,111.12
				Accounts Payable	4,111.12	
				FUND TOTAL	4,111.12	4,111.12
701 Internal Service Fund 701-100100 701-200000	2026 10	265	04/21/2026	Cash-General		45,440.95
				Accounts Payable	45,440.95	
				FUND TOTAL	45,440.95	45,440.95
751 JPA Operations 751-100100 751-200000	2026 10	265	04/21/2026	Cash-General		6,690.28
				Accounts Payable	6,690.28	
				FUND TOTAL	6,690.28	6,690.28
999 Pooled Cash 999-100100 999-201010 999-207010 999-207510	2026 10	265	04/21/2026	Cash-General		56,242.35
				Due to/Due Frm Potable Wtr Ops	4,111.12	
				Due to/Due FromInternal Sys	45,440.95	
				Due to/Due FromJPA Operations	6,690.28	
				FUND TOTAL	56,242.35	56,242.35

A/P CASH DISBURSEMENTS JOURNAL
JOURNAL ENTRIES TO BE CREATED

FUND	DUE TO	DUE FR
101 Potable Water Operations		4,111.12
701 Internal Service Fund		45,440.95
751 JPA Operations		6,690.28
999 Pooled Cash		
	56,242.35	
	TOTAL	56,242.35

** END OF REPORT - Generated by Thieu Chau **

A/P CASH DISBURSEMENTS JOURNAL

JOURNAL ENTRIES TO BE CREATED

CLERK: 3296tchau

YEAR PER	JNL	SRC ACCOUNT	EFF DATE	JNL DESC	REF 1	REF 2	REF 3	ACCOUNT DESC LINE DESC	T OB	DEBIT	CREDIT
2026 10	266	APP 751-200000	04/21/2026	042126B	042126			Accounts Payable		21,642.00	
		APP 999-100100	04/21/2026	042126B	042126			AP CASH DISBURSEMENTS JOURNAL			21,642.00
								Cash-General			
								AP CASH DISBURSEMENTS JOURNAL			
								GENERAL LEDGER TOTAL		21,642.00	21,642.00
APP 999-207510			04/21/2026	042126B	042126			Due to/Due FromJPA Operations		21,642.00	
APP 751-100100			04/21/2026	042126B	042126			Cash-General			21,642.00
								SYSTEM GENERATED ENTRIES TOTAL		21,642.00	21,642.00
								JOURNAL 2026/10/266 TOTAL		43,284.00	43,284.00

A/P CASH DISBURSEMENTS JOURNAL
 JOURNAL ENTRIES TO BE CREATED

FUND	ACCOUNT	YEAR	PER	JNL	EFF DATE	ACCOUNT DESCRIPTION	DEBIT	CREDIT
751	JPA Operations	2026	10	266	04/21/2026			
	751-100100					Cash-General		21,642.00
	751-200000					Accounts Payable	21,642.00	
						FUND TOTAL	21,642.00	21,642.00
999	Pooled Cash	2026	10	266	04/21/2026			
	999-100100					Cash-General		21,642.00
	999-207510					Due to/Due From JPA Operations	21,642.00	
						FUND TOTAL	21,642.00	21,642.00

A/P CASH DISBURSEMENTS JOURNAL
JOURNAL ENTRIES TO BE CREATED

FUND		DUE TO	DUE FR
751	JPA Operations		21,642.00
999	Pooled Cash	21,642.00	
TOTAL		21,642.00	21,642.00

** END OF REPORT - Generated by Thieu Chau **



DATE: May 13, 2026
TO: Board of Directors
FROM: General Manager

SUBJECT: Los Angeles County 2026 Water Resiliency Summit: Board Member Attendance

SUMMARY:

The Las Virgenes Municipal Water District Code (Code), Section 2-2.106(d) – Compensation, designates specific organizational events that directors are authorized to attend. The Los Angeles County 2026 Water Resiliency Summit is not currently covered by the Code; therefore, the Board must authorize the expenses associated with attendance.

RECOMMENDATION(S):

Authorize Board Member attendance and per diem compensation for the Los Angeles County 2026 Water Resiliency Summit to be held on May 18, 2026.

FISCAL IMPACT:

Yes

ITEM BUDGETED:

Yes

FINANCIAL IMPACT:

The event is free. Sufficient funds are available in the adopted Fiscal Year 2025-26 Budget for per diem compensation and travel expenses.

GOALS:

Provide Safe and Quality Water with Reliable Services

Prepared by: Nancy Lawrence, Executive Assistant/Clerk of the Board

ATTACHMENTS:

Agenda for Los Angeles County 2026 Water Resiliency Summit

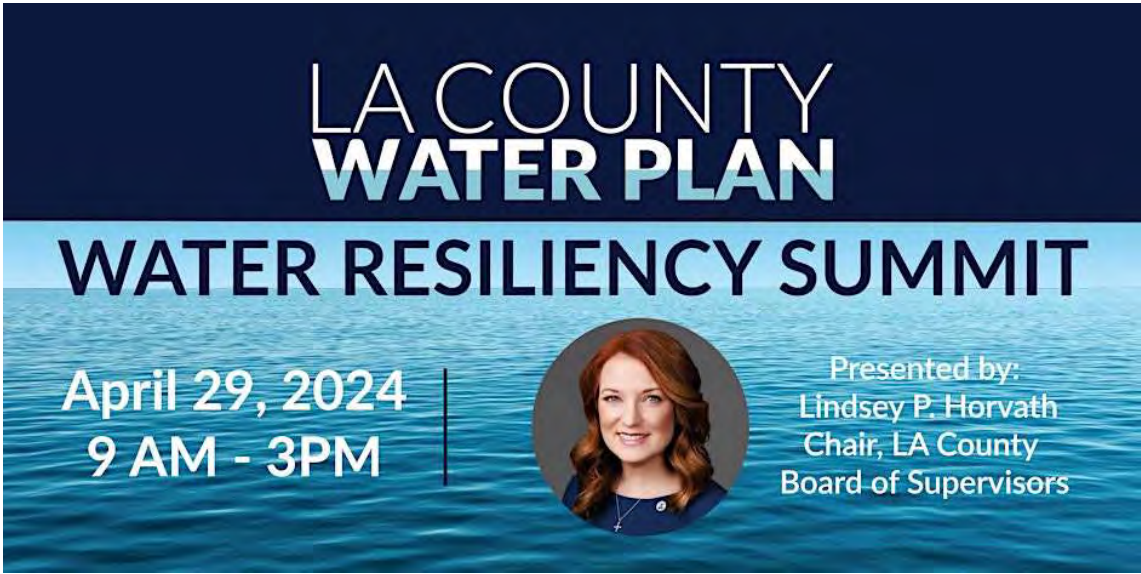

**LA COUNTY
WATER PLAN**

WATER RESILIENCY SUMMIT

April 29, 2024
9 AM - 3PM

Presented by:
Lindsey P. Horvath
Chair, LA County
Board of Supervisors

Join us for the LA County Water Plan Water Resiliency Summit on April 29th to kick off the implementation of the LA County Water Plan!

Water Resiliency Summit Agenda

Date: April 29, 2024

9:00 AM – 9:30 AM
Opening Remarks, LA County Supervisor Lindsey Horvath

Speaker:



Lindsey Horvath

9:30 AM – 10:00 AM
LA County Water Plan Overview

Speaker:



Mark Pestrella

10:00 AM – 10:45 AM
Panel Discussion: Conservation as a Way of Life

Moderator:



Charley Wilson

Speakers:

Adam Arika

Karla Nemeth

Liz Crosson

Rita Kampalath



Tracy Quinn

10:45 AM – 11:00 AM

Break

11:00 AM – 11:45 AM

Panel Discussion: Regional Water Reliability

Moderator:



David Pedersen

Speakers:



Mark Gold



Matt Knudson



Robert Ferrante



Barbara Romero

11:45 AM – 12:30 PM

Networking Lunch

12:30 PM – 1:15 PM

Panel Discussion: Sustainability & Nature-Based Solutions

Moderator:



Eileen Alduenda

Speakers:



Rudy Ortega Jr.



Bruce Reznik



Mark Lombos



Kelsey Jessup

1:15 PM – 1:30 PM

Networking Break

1:30 PM – 2:30 PM

Task Force Breakout Session

- Water Conservation & Communication
- Regional Water Reliability
- Small, At-Risk Water Systems
- Nature-Based Solutions

2:30 PM – 2:45 PM

Closing Remarks

English ▼



DATE: May 13, 2026
TO: Board of Directors
FROM: Finance and Technology

SUBJECT: Update to the District's Investment Policy

SUMMARY:

On April 21, 2026, the Board completed its annual review of the District's Investment Policy. Staff proposes adoption of an update to the Investment Policy to incorporate several minor changes discussed with the Board.

RECOMMENDATION(S):

Pass, approve and adopt proposed Resolution No. 2673, adopting a revised Investment Policy pursuant to Section 2-6.502 of the Las Virgenes Municipal Water District Code.

RESOLUTION NO. 2673

A RESOLUTION OF THE BOARD OF DIRECTORS OF LAS VIRGENES MUNICIPAL WATER DISTRICT ADOPTING A REVISED INVESTMENT POLICY

(Reference is hereby made to Resolution No. 2673 on file in the District's Resolution Book and by this reference the same is incorporated herein.)

DISCUSSION:

On April 21, 2026, the Board reviewed and discussed the following updates to the District's Investment Policy.

Allowable Investments:

Staff proposes to expand the District's allowable investments to include the following instruments allowed pursuant to Section 53601 of the California Government Code and to establish the following maximum limits.

- Supranational Organizations Bonds (i.e. World Bank) – 10% limit
- Commercial Paper – 5% limit
- Corporate Bonds (medium-term notes) – 5% limit

- Zero-Coupon Securities

Investment Pools:

Modify and expand the maximum amount of the portfolio allowed to be invested in local agency investment pools (e.g. Local Agency Investment Fund (LAIF) and California Asset Management Program (CAMP)) to the current LAIF limit of \$75,000,000.

Other Changes:

The proposed Investment Policy also includes other minor corrections and updates to reflect current best practices and terminology.

GOALS:

Ensure Effective Utilization of the Public's Assets and Money

Prepared by: Donald Patterson, Assistant General Manager

ATTACHMENTS:

[Proposed Resolution No. 2673](#)

[Updated Investment Policy - Clean Version](#)

[Updated Investment Policy - Redlined Version](#)

RESOLUTION NO. 2673

A RESOLUTION OF THE BOARD OF DIRECTORS OF
LAS VIRGENES MUNICIPAL WATER DISTRICT
ADOPTING A REVISED INVESTMENT POLICY

BE IT RESOLVED BY THE BOARD OF DIRECTORS OF LAS VIRGENES
MUNICIPAL WATER DISTRICT as follows:

1. Purpose.

This resolution amends Resolution 2519 and replaces the Investment Policy approved on June 13, 2017 in its entirety.

2. Amendment.

Section 2-6.502 of the Las Virgenes Municipal Code requires that the Board shall adopt an investment policy for the District. This provision also provides the minimum items for the policy to address. This resolution adopts a revised policy pursuant to Administrative Code section 2-6.502.

2. Adoption of Investment Policy.

Pursuant to Administrative Code 2-6.502, the District adopts the Investment Policy attached hereto as Exhibit A.

3. Other.

Pursuant to Administrative Code section 2-6.503, this Investment Policy shall be publically available upon request to the Clerk of the Board, and shall be posted on the **District's website**.

PASSED, APPROVED AND ADOPTED on May 13, 2026.

Andy Coradeschi, President

ATTEST:

Gary Burns, Secretary

(SEAL)

Approved as to Form:

W. Keith Lemieux, District Counsel



Investment Policy

Adopted May 13, 2026

This page intentionally left blank.

TABLE OF CONTENTS

1.0	AUTHORITY	1
2.0	POLICY STATEMENT	1
3.0	SCOPE.....	1
4.0	OBJECTIVES	2
5.0	DELEGATION OF AUTHORITY	2
6.0	STANDARD OF CARE	3
7.0	ETHICS AND CONFLICTS OF INTEREST	3
8.0	AUTHORIZED FINANCIAL DEALERS AND INSTITUTIONS	4
9.0	AUTHORIZED AND SUITABLE INVESTMENTS.....	5
10.0	INVESTMENT POOLS / MUTUAL FUNDS	5
11.0	COLLATERALIZATION.....	6
12.0	SAFEKEEPING AND CUSTODY	6
13.0	DIVERSIFICATION	7
14.0	MAXIMUM MATURITIES.....	7
15.0	INTERNAL CONTROL.....	8
16.0	PERFORMANCE STANDARDS.....	8
17.0	CREDIT DOWNGRADE	8
18.0	REPORTING.....	9
19.0	INVESTMENT POLICY ADOPTION	10
	Appendix A - AUTHORIZED INVESTMENTS.....	11
	Appendix B - SUMMARY OF AUTHORIZED INVESTMENTS:	16
	Appendix C - GLOSSARY OF TERMS.....	17
	Appendix G - LIST OF PRIMARY GOVERNMENT SECURITIES DEALERS	32

**Las Virgenes Municipal Water District
Investment Policy
Adopted May 13, 2026**

1.0 AUTHORITY

This Investment Policy was adopted by the Board of Directors of the Las Virgenes Municipal Water District at its regular meeting on May 13, 2026. Any modifications to this policy must be approved by the Board of Directors at a duly noticed public meeting.

2.0 POLICY STATEMENT

It is the policy of Las Virgenes Municipal Water District (“District”) to invest public funds in a manner that provides the maximum security and best investment return, while meeting the daily cash flow demands of the District and conforming to laws governing the investment of public funds.

3.0 SCOPE

This Investment Policy applies to all investment activities and financial assets of the District. Funds held by trustees or fiscal agents are excluded from this policy; however, such funds are subject to regulations established by the State of California. Funds subject to this policy are accounted for in the District’s audited Annual Comprehensive Financial Report (ACFR).

3.1 Funds Covered by this Policy:

- A. Potable Water
- B. Recycled Water
- C. Sanitation
- D. Rate Stabilization
- E. Internal Services
- F. Insurance Reserve
- G. Joint Powers Authority
- H. Any new fund created by the District unless specifically exempted.

3.2 Funds Excluded From This Policy:

- A. Pension Funds
- B. Other Post-Employment Benefit Funds
- C. Funds related to debt issues controlled by specific provisions of the issuance documents
- D. Deferred compensation program funds

The District pools its funds to maximize investment earnings and increase efficiencies for investment pricing, safekeeping, and administration. Investment income is allocated to the various funds proportionally and in accordance with Generally Accepted Accounting Principles (GAAP).

4.0 OBJECTIVES

The primary objectives, in priority order, of the District's investment activities shall be:

4.1 **Safety:** Safety of principal is the foremost objective of the investment program. Investments of the District shall be undertaken in a manner that seeks to ensure the preservation of capital in the overall portfolio. To attain this objective, the District will diversify its investments in a manner that reduces credit and duration risks. Also, the District will invest funds among a variety of securities offering independent returns and financial institutions.

4.2 **Liquidity:** The District's investment portfolio will remain sufficiently liquid to enable the District to meet all operating requirements that may be reasonably anticipated.

4.3 **Return on Investment:** The District's Investment Policy shall be designed with the objective of attaining a benchmark rate of return throughout budgetary and economic cycles, commensurate with the District's investment risk constraints and the cash flow characteristics of the portfolio in a manner that reduces interest rate risk.

5.0 DELEGATION OF AUTHORITY

The Treasurer is a member of the Board of Directors and responsible for the investments. Daily management responsibility for the investment program is delegated to a Deputy Treasurer, normally the Assistant General Manager or Director of Finance and Technology. The Deputy Treasurer shall establish written procedures for the operation of the investment program consistent with this Investment Policy. Procedures should include reference to safekeeping, wire transfer agreements, banking service contracts and collateral/depository agreements. Such procedures shall include explicit delegation of authority to persons responsible for investment transactions.

No person may engage in an investment transaction except as provided under the terms of this policy and the procedures established by the Deputy Treasurer. The Deputy Treasurer shall establish a system of controls to regulate the activities of subordinate designees.

Unless otherwise specifically designated by the District’s Board of Directors, the only officials authorized to undertake investment transactions on behalf of the District are the:

- Treasurer (Board Member)
- Deputy Treasurer
- Deputy Treasurer Designee(s)

Further, no person may engage in an investment transaction except as provided under the terms of the District’s Investment Policy.

6.0 STANDARD OF CARE

In compliance with California Government Code Section 53600.3, the standard of care to be used by investment officials shall be the “prudent investor” standard and applied in the context of managing an overall portfolio. Investment officers acting in accordance with written procedures and the Investment Policy and exercising due diligence shall be relieved of personal liability for an individual security’s credit risk or market price changes, provided deviations from expectations are reported in a timely fashion and appropriate action is taken to control adverse developments.

The “prudent investor” standard states that:

“When investing, reinvesting, purchasing, acquiring, exchanging, selling, or managing public funds, a trustee shall act with care, skill, prudence, and diligence under the circumstances then prevailing, including, but not limited to, the general economic conditions and the anticipated needs of the agency, that a prudent person acting in a like capacity and familiarity with those matters would use in the conduct of funds of a like character and with like aims, to safeguard the principal and maintain the liquidity needs of the agency.”¹

7.0 ETHICS AND CONFLICTS OF INTEREST

The Treasurer, Deputy Treasurer and other employees involved in the investment process shall refrain from personal business activity that could conflict with proper execution of the investment program or which could impair their ability to make impartial investment decisions.

The Treasurer, Deputy Treasurer and other employees involved in the investment process shall disclose any material interests in financial institutions with which they conduct business. They shall further disclose any personal financial/investment positions that could be related to the performance of the investment portfolio and shall not undertake personal investment transactions through the same institution with whom business is conducted on behalf of the District.

The Treasurer, Deputy Treasurer and all District staff with delegated authority for any aspect of the investment process are required to file annual disclosure statements as required by the California Fair Political Practices Commission ("FPPC"), including Forms A-1 and A-2. During the course of the year, if an event subject to disclosure could impair the ability of the Treasurer, Deputy Treasurer or others to make impartial decisions, the Board of Directors will be notified in writing by the General Manager within 10 days of the event.

8.0 AUTHORIZED FINANCIAL DEALERS AND INSTITUTIONS

The District shall transact business only with banks, savings and loans, and registered investment securities dealers. The purchase of any investment, other than those purchased directly from the issuer, shall be purchased either from an institution licensed by the State as a **broker/dealer**, as defined in Section 25004 of the Corporations Code, who is a member of the National Association of Securities Dealers, a member of a Federally regulated securities exchange, a National or State-Chartered Bank, a Federal or State Association (as defined by Section 5102 of the Financial Code), or a brokerage firm designated as a **primary dealer** by the **Federal Reserve Bank**. In addition, a list shall also be maintained by the Deputy Treasurer of approved security broker/dealers who are authorized to provide investment services in California. The District may only conduct business with entities considered "primary" or "regional" dealers that qualify under Securities and Exchange Commission Rule 15C3-1 (uniform net capital rule).

The Deputy Treasurer and his/her assigned staff shall investigate all institutions that wish to do business with the District, in order to determine if they are adequately capitalized, make markets in securities appropriate to the District's needs, and agree to abide by the conditions set forth in this Investment Policy. All financial institutions and broker/dealers that desire to become qualified bidders for investment transactions must provide the District with the following:

- Current audited financial statements;
- Proof of FINRA certification;
- Proof of National Association of Security Dealers (NASD) certification;
- Proof of California registration;
- Completed District questionnaire - Appendix "D" or Appendix "E";
- Evidence of adequate insurance coverage; and
- Certification of having read, understood, and agreed to comply with the District's Investment Policy.

The Deputy Treasurer shall conduct an annual review of the financial condition of all approved financial institutions and broker/dealers in order to determine whether they continue to meet the District's guidelines for qualifications as defined in this section. In addition, the District shall give all approved broker/dealers a copy of the District's Investment Policy on an annual basis. The Deputy Treasurer shall keep current audited annual financial statements on file for each approved financial institution and broker/dealer with which the District does business with for a minimum period of three years.

9.0 AUTHORIZED AND SUITABLE INVESTMENTS

The District shall only invest in instruments authorized pursuant to Sections 16429.1, 53600 et seq., and 53638 of the Government Code and explicitly authorized by the Board subject to the prohibitions set forth in Section 9.1 of this Investment Policy. Appendix A includes a listing of all authorized types of investment securities.

9.1 Prohibited Investments and Transactions

Any investment not specifically authorized in Appendix A is ineligible. The use of derivatives, options, futures or buying on margin is also specifically prohibited. Security transactions shall be conducted on a delivery-versus-payment basis. Securities purchased or acquired by the District shall be held in safekeeping by a third party only pursuant to a custodial agreement as required by Government Code Section 53601.

Also, Government Code Section 53601.6 prohibits local agencies from investing in certain instruments, including inverse floaters, range notes, and mortgage-derived interest only strips. Additionally, the District shall not invest funds in securities that could result in zero interest if held to maturity. Notwithstanding the prohibition above, the District may invest in securities issued or backed by the United States government that could result in zero interest accrual if held to maturity, such as Treasury discount notes.

10.0 INVESTMENT POOLS / MUTUAL FUNDS

The Treasurer shall thoroughly investigate any pooled investment funds, including mutual funds. To accomplish this, a questionnaire (Appendix F) is to be used to evaluate the suitability of the pooled fund. The questionnaire will address the following:

- A description of eligible investment securities, and a written statement of investment policy and objectives;
- A description of interest calculations and how it is distributed, and how gains and losses are treated;
- A description of how the securities are safeguarded (including the settlement processes), and how often the securities are priced and the program is audited;
- A description of who may invest in the program, how often, what size of deposits and withdrawals are allowed;
- A schedule for receiving statements and portfolio listings;
- A description of how reserves and retained earnings are utilized by the pool/fund;
- A fee schedule, and when and how fees are assessed; and
- Whether the pool/fund is eligible for bond proceeds and/or if it will accept such proceeds?

The State of California Local Agency Investment Fund (LAIF) established by Government Code 16429.1 et seq. is explicitly authorized and, therefore, not subject to the provisions of this section.

11.0 COLLATERALIZATION

Pursuant to Government Code Sections 53652 through 53667, the District requires depositories to post certain types and levels of collateral for public funds above the Federal Deposit Insurance Corporation ("FDIC") insurance amounts. The collateral requirements apply to bank deposits, both active (checking and savings accounts) and inactive (non-negotiable time certificates of deposit).

The Treasurer shall require collateralization on two other types of investments: repurchase and reverse agreements. In order to anticipate market changes and provide a level of security for all funds, the collateralization level will be 110% of market value of principal and accrued interest and the value shall be adjusted no less than quarterly. The District requires the collateral to be in the form of U.S. Treasuries or a similar highly liquid instrument.

Collateral will always be held by an independent third party with whom the entity has a current written custodial agreement. A clearly marked evidence of ownership (safekeeping receipt) must be supplied to the District and retained throughout District retention of the investment. The right of collateral substitution is granted.

12.0 SAFEKEEPING AND CUSTODY

To protect against fraud, embezzlement, or losses caused by collapse of individual securities dealers, all securities owned by the District shall be held in safekeeping by the District's custodial bank acting as agent for the District under the terms of a custody agreement. Such custodial bank must be a federal or state association (as defined by Section 5102 of the Financial Code), a trust company or a state or national bank located within this state or with the Federal Reserve Bank of San Francisco or any branch thereof within this state, or with any Federal Reserve bank or with any state or national bank located in any city designated as a reserve city by the Board of Governors of the Federal Reserve System. Collateral for repurchase agreements will be held by a third party custodian under the terms of a Public Securities Association ("PSA") master repurchase agreement.

All security transactions entered into by the District shall be conducted on a delivery-versus-payment (DVP) basis. This procedure ensures that securities are deposited with the third party custodian prior to the release of funds. Securities will be held by a third party custodian designated by the Treasurer or Deputy Treasurer and as evidenced by safekeeping receipts with a written custodial agreement. Pooled Investments, such as LAIF and other local agency pooled investments or money market mutual funds as described in Appendix A are undeliverable and, therefore, not subject to delivery or third party safekeeping. The Deputy Treasurer shall not be responsible for securities delivered to and receipted for by a financial institution until they are withdrawn from the financial institution by the Deputy Treasurer or the Deputy Treasurer's designee.

Investment trades, shall be verified against the bank transactions and broker confirmation tickets to ensure accuracy. On a monthly basis, the custodial asset statement shall be reconciled with the month-end portfolio holdings. On an annual basis, the external auditor shall confirm investment holdings.

13.0 DIVERSIFICATION

The District will diversify its investments by security type, institution, and maturity. With the exception of U.S. Treasury securities and authorized pools, no more than 50% of the District's total investment portfolio will be invested in a single security issuer or with a single financial institution. The Treasurer shall to the greatest extent possible:

- Limit investments to avoid over-concentration in securities from a specific issuer or business sector (excluding U.S. Treasury securities),
- Limit investments in securities that have higher credit risks,
- Invest in securities with varying maturities, and
- Continuously invest a minimum amount equal to six months operating budget in readily available funds such as local government investment pools (LAIF), money market funds or overnight repurchase agreements to ensure that appropriate liquidity is maintained in order to meet the District's on-going financial obligations.

13.1 Portfolio Rebalancing

In the event that portfolio percentage constraints are violated due to a temporary imbalance in the portfolio, the District shall hold the affected securities to maturity in order to avoid capital losses. However, if no capital losses would be realized upon sale, the Treasurer, Deputy Treasurer or his/her designee shall consider rebalancing the portfolio after evaluating the expected length of time the portfolio would remain unbalanced. Since portfolio percentage limits are in place to ensure diversification of the District Investment portfolio, a small, temporary imbalance will not significantly impair the strategy.

14.0 MAXIMUM MATURITIES

To minimize the impact of market risk, it is intended that all investments be held to maturity.

The Deputy Treasurer shall match the District's investments with anticipated cash flow requirements known at the time of purchase. The District will not directly invest in securities maturing more than five (5) years from the settlement date, except as specified below. Any investment that is further limited is noted in Appendix A, Authorized Investments. Also, Appendix B provides a listing of maximum maturities by investment vehicle. The weighted average maturity of the investment portfolio will be based on the anticipated cash flow needs of the District for the upcoming five-year period as monitored through its ten-year financial model.

The Board grants authority to invest in securities with a remaining term in excess of five years as part of the District's overall investment program. Per that authorization, up to 5% of the portfolio value may be invested in U.S. government, Federal Agency, or Municipal securities with remaining maturities at the time of purchase between five and ten years. Per State law, the settlement date of the investment purchase is considered the start date of the remaining term to maturity. Further maturity limitations per State Code are shown in Appendix A.

15.0 INTERNAL CONTROL

The Deputy Treasurer shall ensure that all investment transactions comply with the District's Investment Policy and establish internal controls that are designed to prevent losses due to fraud, negligence or third-party misrepresentation. These controls shall be designed to avoid collusion; ensure separation of duties and administrative controls; maintain separation of transaction authority from accounting and record keeping; provide custodial safekeeping; delegate authority clearly; ensure management approval and review of investment transactions; provide specific limitations regarding securities loss and remedial action; document investment transactions and strategies; and monitor investment performance results.

The Deputy Treasurer shall establish an annual process of independent review by an external audit firm. The external auditor shall review the management of the District's investment program in terms of compliance with the internal controls previously established.

The external auditor, serving as an independent reviewer, will review and verify the District's investment activity, holdings and compliance with this Investment Policy on an annual basis and submit a report to the District's Board of Directors relating thereto.

16.0 PERFORMANCE STANDARDS

The investment portfolio shall be designed with the objective of obtaining a rate of return throughout budgetary, economic, or weather cycles, commensurate with the investment risk constraints and cash flow needs. The District's investment portfolio, exclusive of investment pools and mutual funds, shall utilize the three-year Treasury note as its benchmark. It is understood that due to the District's policy to hold investments to maturity, short-term yields will lag the direction of the three-year Treasury note in changing interest rate environments.

17.0 CREDIT DOWNGRADE

If a security is downgraded below the minimum credit risk criteria specified in the Investment Policy, the Deputy Treasurer shall evaluate the downgrade and bring their evaluation back to the Treasurer and General Manager to evaluate and decide what action to take: continue to monitor and hold through maturity or sell the security on the secondary market.

18.0 **REPORTING**

The District's Investment Policy shall be reviewed on an annual basis by the Treasurer, Deputy Treasurer, and General Manager with recommendations for changes, if any, made to the Board of Directors.

The District shall maintain a complete and accurate record of all investment transactions.

18.1 **Monthly Reports:** The Deputy Treasurer shall prepare and submit a monthly investment report of funds directly controlled and managed by the District, including a detailed listing of all investment transactions opened and closed during a reporting period or, if none, a statement to that effect. The report shall be submitted monthly to the Board of Directors.

Each investment report shall be submitted within 45 days following the end of the period covered by the report and must also include certification by the General Manager that investment actions executed since the last report are in compliance with the Investment Policy or state areas of non-compliance; and the District will meet its expenditure obligations for the next six months or state why sufficient money shall, or may, not be available as required by law.

Schedules in the monthly report should include the following:

- The type of investment, name of the issuer, date of maturity, the par value, book value, yield to maturity or yield to call, and cost of all funds invested and subject to this policy;
- Coupon, discount or earnings rate;
- Percentage of the portfolio represented by each investment category; and
- The market value with the source of the market valuation for all securities held by the District, and under management of any outside party that is not also a local agency or the State of California Local Agency Investment Fund.

18.2 **Quarterly Report:** Within 30 days of the end of each quarter, the Deputy Treasurer shall prepare and submit a quarterly investment report to the Board that includes the information required in the monthly investment report, plus the following additional information:

- A description of any investments, including loans and security lending programs, that are under the management of contracted parties;
- A description of the compliance with the statement of Investment Policy, or manner in which the portfolio is not in compliance;
- A statement denoting the District's ability to meet its expenditure requirements for the next six months, or an explanation as to why sufficient money shall, or may, not be available;
- A benchmark comparison;
- A statement of cash and investments held and compliance with adopted reserve policies; and
- A narrative analysis with supporting graphs and/or charts that provide information on performance of the portfolio, as well as general economic and operational trends

affecting the portfolios size and/or performance.

The investment portfolio will be managed in accordance with the parameters specified within this policy and monitored and evaluated by the Deputy Treasurer and his/he designated employees involved in the investment process.

19.0 INVESTMENT POLICY ADOPTION

The District's Investment Policy shall be adopted by the Board of Directors. The policy shall be reviewed at least annually to ensure its consistency with the overall objectives of preservation of principal, liquidity, and return on investment, and its relevance to current law, financial and economic trends, and to meet the needs of the District. Any modifications made hereto must be approved by the Board of Directors.

Appendix A - AUTHORIZED INVESTMENTS

1. **UNITED STATES TREASURIES:**

United States Treasury notes, bonds, bills, or certificates of indebtedness, or those for which the faith and credit of the United States are pledged for the payment of principal and interest.

There is no limit as to the amount of the investment portfolio that may be invested in United States Treasury notes. Maximum maturity is five years from the settlement date.

2. **FEDERAL AGENCIES:**

Obligations issued by the United States Government Agencies, such as the Federal Farm Credit Bank System (FFCB), the Federal Home Loan Bank Board (FHLB), the Federal National Mortgage Association (FNMA), Federal Home Loan Mortgage Corporation (FHLMC), the Tennessee Valley Authority (TVA), or obligations, participation, or other instruments of, or issued by a federal agency or a United States government-sponsored enterprise.

There is no limit as to the amount of the investment portfolio that may be invested in federal agencies. Maximum maturity is five years from the settlement date.

3. **STATE BONDS:**

Registered state warrants, treasury notes or bonds of this state and any of the 50 states and the District of Columbia, including bonds payable solely out of the revenues from a revenue-producing property owned, controlled, or operated by the state or by a department, board, agency, or authority of the state. The long-term ratings of such bonds should have at least AA- by Standard and Poor's (S&P), AA- by Fitch or Aa3 by Moody's, or the short-term ratings should have at least A-1 by S&P, and P-1 by Moody's.

There is no limit as to the amount of the investment portfolio that may be invested in state bonds. Maximum maturity is five years.

4. **LOCAL AGENCY BONDS:**

Bonds and notes issued by local agencies (cities, counties, special districts, or schools) of the United States, including bonds payable solely out of the revenues from a revenue-producing property owned, controlled, or operated by the local agency, or by a department, board, agency, or authority of the local agency, such as Las Virgenes Municipal Water District. The maturity of such bonds or notes should not exceed five years from the date of purchase. The long-term ratings of such bonds should be

investment grade (at least AA- by Standard and Poor's (S&P), KBRA or Fitch or Aa3 by Moody's, or the short-term ratings should have at least A-1 by S&P, and P-1 by Moody's).

There is no limit as to the amount of the District's portfolio may be invested in local agency bonds. Maximum maturity is five years.

5. **LOCAL GOVERNMENT INVESTMENT POOLS:**

Local government investment pools, that adhere to the California Government Code parameters for eligible investments.

A. LAIF:

State managed Local Agency Investment Fund ("LAIF") pursuant to Government Code Section 16429.1 and Resolution No. 01-04-2291 of the Las Virgenes Municipal Water District.

The maximum amount an agency may invest in LAIF is \$65,000,000 pursuant to the LAIF policy.

B. Local Agency Pooled Investment Funds: Other local agency pooled investment funds that invest pursuant to California Government Code Section 53601 or 53635, as authorized by the Board.

No more than 25 percent of the District's total portfolio value may be invested in other local agency pooled investment funds.

6. **REPURCHASE/REVERSE REPURCHASE AGREEMENTS:**

a.) Investments in repurchase agreements or reverse repurchase agreements of any securities authorized by this section, so long as the agreements are subject to this subdivision, including, the delivery requirements specified in this section. All transactions in repurchase agreements or reverse repurchase agreements shall require a master repurchase agreement executed by the contra-party.

b.) Investments in repurchase agreements may be made, on any investment authorized in this section, when the term of the agreement does not exceed 30 days. The market value of securities that underlies a repurchase agreement must be valued at 110 percent or greater of the funds borrowed against those securities and the value shall be adjusted no less than quarterly.

- c.) Investments in reverse repurchase agreements or similar investments in which the District sells securities prior to purchase, may only be made upon prior approval of the Board of Directors and with a maximum maturity of 30 days.
- d.) (1) "Repurchase agreement" means a purchase of securities by the District pursuant to an agreement by which the counter-party seller will repurchase the securities on or before a specified date and for a specified amount and the counter-party will deliver the underlying securities to the District by book entry, physical delivery, or by third party custodial agreement. The transfer of underlying securities to the counter-party bank's customer book-entry account may be used for book-entry delivery.
- (2) "Securities," for purpose of repurchase under this subdivision, 4 means securities of the same issuer, description, issue date, and maturity.
- (3) "Reverse repurchase agreement" means a sale of securities by the District pursuant to an agreement by which the District will repurchase the securities on or before a specified date and includes other comparable agreements.
- (4) For purposes of this section, the base value of the District's pool portfolio shall be that dollar amount obtained by totaling all cash balances placed in the pool by all pool participants, excluding any amounts obtained through selling securities by way of reverse repurchase agreements or other similar borrowing methods.
- (5) For purposes of this section, the spread is the difference between the cost of funds obtained using the reverse repurchase agreement and the earnings obtained on the reinvestment of the funds.
- (6) Repurchase agreements and reverse repurchase agreements shall only be made with primary dealers of the Federal Reserve Bank of New York.

Repurchase agreements may not exceed 25 percent of the District's investment portfolio value. Reverse repurchase agreements may not exceed 10 percent of the District's investment portfolio value.

7. **MONEY MARKET MUTUAL FUNDS:**

Shares of beneficial interest issued by diversified management companies (otherwise known as “mutual funds”), as defined in Section 23701 of the Revenue and Taxation Code, investing in the securities and obligations as authorized by subdivisions (1) to (12), inclusive, of this section and that comply with the investment restrictions of Article 1 (commencing with Section 53600) and Article 2 (commencing with Section 53630). To be eligible for investment pursuant to this subdivision, these companies shall either:

a) Attain the highest ranking or the highest letter and numerical rating provided by not less than two of the three largest nationally recognized rating services.

b) Commission with not less than five years' experience investing in the securities and obligations as authorized by this Investment Policy, inclusive, and with assets under management in excess of five hundred million dollars (\$500,000,000).

The purchase price of shares of beneficial interest purchased pursuant to this subdivision shall not include any commission that these companies may charge.

The purchase of money market mutual funds shall not exceed 20 percent of the District's total portfolio value; however, no more than 10 percent of the District's investment portfolio value may be invested in shares of beneficial interest of any one money market mutual fund.

8. **CERTIFICATES OF DEPOSIT:**

A. Negotiable, non-negotiable, and placement service certificates of deposits issued by a nationally or state-chartered bank or a state or federal association (as defined by Section 5102 of the Financial Code) or by a state-licensed branch of a foreign bank. The issuing firm should have been in existence for at least five years.

1. Federally insured negotiable Certificates of Deposits up to \$250,000.
2. Certificates of Deposit that are fully collateralized. To collateralize such deposits, an institution shall maintain in the collateral pool securities having a market value of at least 10% in excess of the total amount deposited. Real estate mortgages may not be accepted as collateral. The maximum term for deposits shall be five years. In general, the issuer must have a minimum tier one risk-based capital ratio of 6% as determined by the FDIC and their operation must have been profitable during their last reporting period.

The term of a Certificate of Deposit shall not exceed 5 years from the settlement date. Purchases of all types of certificates of deposit may not exceed 25 percent of the District's portfolio value which may be invested pursuant to this section.

9. **PLACEMENT SERVICE DEPOSITS** - Service that allows a local agency to purchase in excess of \$250,000 in deposits, placing monies with other institutions while maintaining FDIC insurance. Placement service deposits may not exceed 25 percent of the District's investment portfolio value.
10. **COMMERCIAL PAPER** – An unsecured, short-term debt instrument issued by corporations typically used to finance short-term liabilities. Terms cannot exceed 270 days except for asset-backed commercial paper with terms up to 397 days. Commercial paper may not exceed 5 percent of the District's portfolio.
11. **CORPORATE (MEDIUM TERM) NOTES** - A debt security issued by a corporation to raise capital for projects, acquisitions, or operations maturing in five years or less.
12. **SUPRANATIONAL OBLIGATIONS** – U.S. dollar denominated debt issued or guaranteed by international organizations such as the International Bank for Reconstruction and Development (IBRD) (aka World Bank), International Finance Corporation (IFC), Inter-American Development Bank (IADB)

Appendix B - SUMMARY OF AUTHORIZED INVESTMENTS:

Authorized Investments	District Policy Legal Limit (% or \$)	Maximum Maturity Constraints	Limits
United States Treasuries	Unlimited	5 years	None
U.S. Agencies	Unlimited	5 years	None
State Bonds	Unlimited	5 years	Rated AA-
Local Agency Bonds	Unlimited	5 years	Rated AA-
LAIF/Other Local Agency Investment Pools	\$75,000,000	N/A	Pools subject to Board approval and statutory limits.
Voluntary Investment Fund	Unlimited	N/A	None
County Pooled Investment Fund	Unlimited	N/A	None
Repurchase Agreements	25%	30 days	Requires a Master Repurchase agreement, market value of underlying securities must be greater than 110%
Reverse Repurchase Agreements	10%	30 days	Prior Board of Directors approval required
Money Market Mutual Funds	20%	N/A	No more than 10% will be invested in any one mutual fund
Non-Negotiable Certificates of Deposit	25%	5 years	None
Negotiable Certificates of Deposit	25%	5 years	All CDs over \$250,000 must be collateralized at 110%.
Placement Service CD	25%	5 years	None
Placement Service Deposits	10%	5 years	None
Commercial Paper	5%	397 days or less	Debt, other than commercial paper must be rated A or higher and commercial paper must be rated A-1 or higher
Corporate Notes	5%	5 years	Must be rated AA or higher
Supranational Obligations	10%	5 years	Must be rated AA or higher

Appendix C - GLOSSARY OF TERMS

ACCRUED INTEREST: The interest owed to the seller of a coupon bearing issue from the last coupon date up to the sale date.

AGENCIES: Federal agency securities and/or Government-sponsored enterprises.

ANNUAL COMPREHENSIVE FINANCIAL REPORT (ACFR): The official annual report for Las Virgenes Municipal Water District. It includes the presentation of required financial

ASKED: The price at which securities are offered.

BANKERS' ACCEPTANCE (BA): A draft of bill or exchange accepted by a bank or trust company. The accepting institution guarantees payment of the bill, as well as the issuer-evidencing a loan created by the accepting bank.

BASIS POINT: 1/100 of one percent (decimally, .0001)

BENCHMARK: A comparative base for measuring the performance or risk tolerance of the investment portfolio. A benchmark should represent a close correlation to the level of risk and the average duration of the portfolio's investments.

BID: The price offered by a buyer of securities. (When you are selling securities, you ask for a bid.) See OFFER.

BROKER: A broker brings buyers and sellers together for a commission.

CALLABLE BOND: A bond that can be bought back from a holder by the issuer at a specific price after a specific date prior to the maturity date.

CERTIFICATE OF DEPOSIT (CD): A time deposit with a specific maturity evidenced by a certificate. Large-denomination CD's are typically negotiable.

CMO (COLLATERALIZED MORTGAGE OBLIGATION): Mortgage-backed bond that separates mortgage pools into short-, medium-, and long-term portions.

COLLATERAL: Securities, evidence of deposit, or other property that a borrower pledges to secure repayment of a loan. Also refers to securities pledged by a bank to secure deposits of public monies.

COMMERCIAL PAPER (CP): An unsecured promissory note issued by a corporation. Maturity may not exceed 270 days. Usually sold in discount form.

statements in conformity with GAAP. It also includes supporting schedules necessary to demonstrate compliance with finance-related legal and contractual provisions, extensive introductory material, and a detailed Statistical Section.

COUPON: a) The annual rate of interest that a bond's issuer promises to pay the bondholder on the bond's face value. b) A certificate attached to a bond evidencing interest due on a payment date.

DEALER: A dealer, as opposed to a broker, acts as a principal in all transactions buying and selling for his own account.

DEBENTURE: A bond secured only by the general credit of the issuer.

DEFAULT: The failure of a debtor to make timely payments of interest and principal as they come due or to meet some other provision of a bond indenture.

DELIVERY VERSUS PAYMENT (DVP): There are two methods of delivery of securities: delivery versus payment and delivery versus receipt. Delivery versus payment is delivery of securities with an exchange of money for the securities. Delivery versus receipt is delivery of securities with an exchange of a signed receipt for the securities.

DERIVATIVE: (1) Financial instruments whose return profile is linked to, or derived from, the movement of one or more underlying index or security, and may include a leveraging factor, or (2) financial contracts based upon notional amounts whose value is derived from a underlying index or security (interest rates, foreign exchange rates, equities or commodities).

DISCOUNT: The difference between the cost price of a security and its maturity when quoted at a lower than face value. A security selling below original offering price shortly after sale also is considered to be at a discount.

DISCOUNTED SECURITIES: Non-interest bearing money market instruments that are issued at a discount and redeemed at maturity for full face value, e.g. U.S. Treasury Bills.

DIVERSIFICATION: Dividing investment funds among a variety of securities offering independent returns.

DURATION: A measure of the sensitivity of the price of a fixed income security to interest rate changes.

FEDERAL CREDIT AGENCIES: Agencies of the Federal government set up to supply credit to various classes of institutions and individuals, e.g., S&L's, small-business firms, students, farmers, farm cooperatives, and exporters.

FEDERAL DEPOSIT INSURANCE CORPORATION (FDIC): A federal agency that insures bank deposits, currently up to \$250,000 per deposit.

FEDERAL FUNDS RATE: The rate of interest at which Fed funds are traded. This rate is currently pegged by the Federal Reserve through open-market operations.

FEDERAL HOME LOAN BANKS (FHLB): Government sponsored wholesale banks (currently 12 regional banks) that lend funds and provide correspondent banking services to member commercial banks, thrift institutions, credit unions, and insurance companies. The mission of the FHLBs is to liquefy the housing related assets of its members who must purchase stock in their district Bank.

FEDERAL NATIONAL MORTGAGE ASSOCIATION (FNMA): FNMA, like GNMA was chartered under the Federal National Mortgage Association Act in 1938. FNMA is a federal corporation working under the auspices of the Department of Housing and Urban Development (HUD). It is the largest single provider of residential mortgage funds in the United States. Fannie Mae, as the corporation is called, is a private stockholder-owned corporation. The corporation's purchases include a variety of adjustable mortgages and second loans, in addition to fixed-rate mortgages. FNMA's securities are also highly liquid and are widely accepted. FNMA assumes and guarantees that all security holders will receive timely payment of principal and interest.

FEDERAL OPEN MARKET COMMITTEE (FOMC): Consists of seven members of the Federal Reserve Board and five of the twelve Federal Reserve Bank Presidents. The President of the New York Federal Reserve Bank is a permanent member, while the other Presidents serve on a rotating basis. The Committee periodically meets to set Federal Reserve guidelines regarding purchases and sales of Government Securities in the open market as a means of influencing the volume of bank credit and money.

FEDERAL RESERVE SYSTEM: The central bank of the United States created by Congress and consisting of seven member Board of Governors in Washington, D.C., 12 regional banks and about 5,700 commercial banks that are members of the system.

GOVERNMENT NATIONAL MORTGAGE ASSOCIATION (GNMA or Ginnie Mae): Securities influencing the volume of bank credit guaranteed by GNMA and issued by mortgage bankers, commercial banks, savings, and loan associations, and other institutions. Security holder is protected by full faith and credit of the U.S. Government, Ginnie Mae securities are backed by the FHA, VA or FmHA mortgages. The term "pass-throughs" is often used to describe Ginnie Maes.

INVERSE FLOATER; A structured note in which the coupon increases as rates decline and decrease as rates rise.

IO (INTEREST ONLY): A class of mortgage derivative in which the cash flow consists solely of the interest payments from a CMO.

LIQUIDITY: A liquid asset is one that can be converted easily and rapidly into cash without a substantial loss of value. In the money market, a security is said to be liquid if the spread between bid and asked prices is narrow and reasonable size can be done at those quotes.

LOCAL GOVERNMENT INVESTMENT POOL (LGIP): The aggregate of all funds from political subdivisions that are placed in the custody of the State Treasurer for investment and reinvestment.

MARKET PRICE: In general business, the price agreed upon by buyers and sellers of a product or service, as determined by supply and demand.

MARKET VALUE: The price at which a security is trading and could presumably be purchased or sold.

MASTER REPURCHASE AGREEMENT: A written contract covering all future transactions between the parties to repurchase – reverse repurchase agreements that establishes each party’s rights in the transactions. A master agreement will often specify, among other things the right of the buyer-lender to liquidate the underlying securities in the event of default by the seller-borrower.

MATURITY: The date upon which the principal or stated value of an investment becomes due and payable.

MONEY MARKET: The market in which short-term debt instruments (bills, commercial paper, banker’s acceptances, etc.) are issued and traded.

NEGOTIABLE CERTIFICATES OF DEPOSIT: Large denomination interest bearing deposits with a fixed maturity date that may be sold in the money market.

OFFER: The price asked by a seller of securities. (When you are buying securities, you ask for an offer.) See ASKED and BID.

OPEN MARKET OPERATIONS: Purchases and sales of government and certain other securities in the open market by the New York Federal Reserve Bank as directed by the FOMC in order to influence the volume of money and credit in the economy. Purchases inject reserves into the bank system and stimulate growth of money and credit; sales have the opposite effect. Open market operations are the Federal Reserve’s most important monetary policy tool.

PAR: 1) 100% of the face amount of an issue. 2) The principal amount a holder will receive at the maturity of an issue.

PORTFOLIO: Collection of securities held by an investor.

PREMIUM: 1) The amount by which the market price of an issue exceeds par. 2) The amount in excess of par that an issuer must pay to call in its bonds. 3) In the money market, the rate higher than the norm that one bank must pay to attract CD depositors.

PRIMARY DEALER: A group of government securities dealers who submit daily reports of market activity and positions and monthly financial statements to the Federal Reserve Bank of New York and are subject to its informal oversight. Primary dealers include Securities and Exchange Commission (SEC)-registered securities broker-dealers, banks, and a few unregulated firms.

PRIME RATE: The loan rate for the best customers of a bank.

PRINCIPAL: 1) The dollar cost of an issue excluding accrued interest. 2) The one who takes ownership in a transaction, as opposed to brokering or acting as agent.

PRUDENT PERSON RULE: An investment standard. In some states the law requires that a fiduciary, such as a trustee, may invest money only in a list of securities selected by the custody state-the so-called legal list. In other states the trustee may invest in a security if it is one which would be bought by a prudent person of discretion and intelligence who is seeking a reasonable income and preservation of capital.

QUALIFIED PUBLIC DEPOSITORIES: A financial institution which does not claim exemption from the payment of any sales or compensating use of ad valorem taxes under the laws of this state, which as segregated for the benefit of the commission eligible collateral having a value of not less than its maximum liability and which has been approved by the Public Deposit Protection Commission to hold public deposits.

RATE OF RETURN: The yield obtainable on a security based on its purchase price or its current market price. This may be the amortized yield to maturity on a bond the current income return.

REPURCHASE AGREEMENT (RP OR REPO): A holder of securities sells these securities to an investor with an agreement to repurchase them at a fixed price on a fixed date. The Security “buyer” in effect lends the “seller” money for the period of the agreement, and the terms of the agreement are structured to compensate him for this. Dealers use RP extensively to finance their positions. Exception: When the Fed is said to be doing RP, it is lend money that is, increasing bank reserves.

SAFEKEEPING: A service to customers rendered by banks for a fee whereby securities and valuables of all types and descriptions are held in the bank's vaults for protection.

SECONDARY MARKET: A market made for the purchase and sale of outstanding issues following the initial distribution.

SECURITIES & EXCHANGE COMMISSION: Agency created by Congress to protect investors in securities transactions by administering securities legislation.

SEC RULE 15C3-1: See Uniform Net Capital Rule.

SPREAD: 1) The yield or price difference between the bid and offer on an issue. 2) The yield or price difference between different issues.

STRUCTURED NOTES: Notes issued by Government Sponsored Enterprises (FHLB, FNMA, SLMA, etc.) and Corporations that have imbedded options (e.g., call features, step-up coupons, floating rate coupons, derivative-based returns) into their debt structure. Their market performance is impacted by the fluctuation of interest rates, the volatility of the imbedded options and shifts in the shape of the yield curve.

SWAP: The sale of one issue and the simultaneous purchase of another for some perceived advantage.

TRADE DATE: The date on which the buyer and seller agree to a transaction. The trade date may or may not be the day on which the securities and money changes hands.

TREASURY BILLS: A non-interest bearing discount security issued by the U.S. Treasury to finance the national debt. Most bills are issued to mature in three months, six months, or one year.

TREASURY BONDS: Long-term coupon-bearing U.S. Treasury securities issued as direct obligations of the U.S. Government and having initial maturities of more than 10 years.

TREASURY NOTES: Medium-term coupon-bearing U.S. Treasury securities issued as direct obligations of the U.S. Government and having initial maturities from two to 10 years.

UNIFORM NET CAPITAL RULE: Securities and Exchange Commission requirement that member firms as well as nonmember broker-dealers in securities maintain a maximum ratio of indebtedness to liquid capital of 15 to 1; also called net capital rule and net capital ratio. Indebtedness covers all money owed to a firm, including margin loans and commitments to purchase securities, one reason new public issues are spread among member so underwriting syndicates. Liquid capital includes cash and assets easily converted into cash.

YIELD: The rate of annual income return on an investment, expressed as a percentage.

INCOME YIELD is obtained by dividing the current dollar income by the current market price for the security. (b) **NET YIELD or YIELD TO MATURITY** is the current income yield minus any premium above par or plus any discount from par in purchase price, with the adjustment spread over the period from the date of purchase to the date of maturity of the bond.

**LAS VIRGENES MUNICIPAL WATER DISTRICT
DEPARTMENT OF FINANCE & TECHNOLOGY**

BANK/SAVINGS AND LOAN QUESTIONNAIRE AND CERTIFICATION

1. Name of Firm: _____
2. Address: _____
3. Telephone No: _____
Direct _____ Nat. Headquarters _____
4. Primary Representative: _____ Manager: _____
Name: _____ Name: _____
Title: _____ Title: _____
Telephone No: _____ Telephone No: _____
5. What is your Community Reinvestment Act ("CRA") Rating? _____
6. What are the Total Assets of the Bank/Savings and Loan? _____

7. What is the current Net Worth Ratio of your institution? _____
8. What was the Net Worth Ratio for the Previous Year? _____
9. What are your required Capital Ratios?
 - A. Tangible Capital Ratio _____
 - B. Core Capital Ratio _____
 - C. Risk-Based Capital Ratio _____
10. What are your Ratings (i.e., S&P, Moody's, Fitch)? _____
11. What is the date of your Fiscal Year-End? _____
Has there been a year during the past three years in which the Bank/Savings and Loan did not make a profit? Yes No
12. Have you read the California Government Code Section 53630 through 53684 pertaining to the State's requirements governing the deposit of monies by Local Agencies? Yes No
13. Amounts above the FDIC insurance coverage must be collateralized as specified in the Government Code. Where is the collateral for Deposits held?

Has there ever been a failure to fully collateralize? If Yes, please attach explanation.
Yes No
14. What is the education level of the Primary Contact(s)? _____
15. How many years of related experience does the Primary Contact(s) have? _____
16. What other banking services would you be interested in providing the District?

- 17. What transaction documents and reports would we receive? _____

- 18. What information would you provide to our Treasurer and/or Deputy Treasurer?

- 19. Describe the precautions taken by your Bank/Savings and Loan to protect the interest of the public when dealing with government agencies as depositors or investors. _____

- 20. Please provide your Contract of Deposit of Moneys pre-signed and sealed by your institution, as well as, any signature cards that you may require.
- 21. Please provide your Wiring Instructions: _____

- 22. Please provide your Bank/Savings and Loan most recent certified financial statement. In addition, an audited financial statement must be provided within 120 days of your fiscal year-end.

- CERTIFICATION -

I hereby certify that I have personally read Las Virgenes Municipal Water District’s (the “District”) Investment Policy and the California Government Codes pertaining to the investments and deposits of the District, and have implemented reasonable procedures and a system of controls designed to preclude imprudent investment activities arising out of transactions conducted between our firm and the District. **I understand however, that our firm is not obligated to monitor the percentage limits on the investments as described in the policy.** All sales personnel will be routinely informed of District investment objectives, horizon, outlook, strategies and risk constraints whenever we are so advised. We pledge to exercise due diligence in informing District Investment Officers of all foreseeable risks associated with financial transactions conducted with our firm. I attest to the accuracy of our responses to your questionnaire.

NOTE: Completion of Questionnaire is only part of District’s Certification process and DOES NOT guarantee that the applicant will be approved to do business with the District.

Signature: _____ Date: _____

Name: _____ Title: _____

Countersigned: _____ Date: _____

Name: _____ Title: _____

-
21. Which of the following instruments are offered regularly by your local desk?
- | | |
|--|---|
| <input type="checkbox"/> T-Bills | <input type="checkbox"/> Treasury Notes/Bonds |
| <input type="checkbox"/> NCD's | <input type="checkbox"/> Agencies (specify) _____ |
| <input type="checkbox"/> BA's (Domestic) | <input type="checkbox"/> BA's (Foreign) |
| <input type="checkbox"/> Mid-Term Notes | <input type="checkbox"/> Commercial Paper |
| <input type="checkbox"/> Repurchase Agreements | <input type="checkbox"/> Reverse Agreements |
22. Which of the above does your firms specialize in Marketing? _____
-
23. Please identify your most directly comparable Local Agency clients in our geographical area:
 Contact Person: _____
 Telephone No: _____ Client Since: _____
24. What reports, transactions, confirmations and paper trail would we receive?

25. Please include samples of research reports or market information that your firm regularly provides to local agency clients.
26. What precautions are taken by your firm to protect the interest of the public when dealing with government agencies as investors? _____
-
27. Have you or your firm been censured or punished by a Regulatory State or Federal Agency for improper or fraudulent activities, related to the sale of securities? Yes No
28. If yes, please explain: _____
-
29. Attach certified documentation of your capital adequacy and financial solvency. In addition, an audited financial statement must be provided within 120 days f your fiscal year-end.

- CERTIFICATION -

I hereby certify that I have personally read Las Virgenes Municipal Water District's (the "District") Investment Policy and the California Government Codes pertaining to the investments and deposits of the District, and have implemented reasonable procedures and a system of controls designed to preclude imprudent investment activities arising out of transactions conducted between our firm and the District. **I understand however, that our firm is not obligated to monitor the percentage limits on the investments as described in the policy.** All sales personnel will be routinely informed of District investment objectives, horizon, outlook, strategies and risk constraints whenever we are so advised. We pledge to exercise due diligence in informing District Investment Officers of all foreseeable risks associated with financial transactions conducted with our firm. I attest to the accuracy of our responses to your questionnaire.

NOTE: Completion of Questionnaire is only part of District's Certification process and DOES NOT guarantee that the applicant will be approved to do business with the District.

Signature: _____ Date: _____

Name: _____ Title: _____

Countersigned: _____ Date: _____

Name: _____ Title: _____

**LAS VIRGENES MUNICIPAL WATER DISTRICT
DEPARTMENT OF FINANCE & TECHNOLOGY**

INVESTMENT POOL QUESTIONNAIRE

SECURITIES

1. Does the pool provide a written statement of investment policy and objectives?
Yes No
2. Does the statement contain the following (check all that apply):
 - A description of eligible investment instruments
 - The credit standards of investments
 - The allowable maturity range of investments
 - The maximum allowable dollar weighted average portfolio maturity
 - The limits of portfolio concentration permitted for each type of security
 - The policy of reverse repos
3. Are the changes in the policies communicated to the pool participants?
Yes No

INTEREST

4. Does the pool disclose the following about yield calculations (check all that apply):
 - Methodology is used to calculate interest (simple maturity, yield to maturity, etc.)
 - Frequency of interest payments
 - How interest is paid
 - How gains/losses are reported (factored monthly or only when realized)
5. How often is the yield reported to participants of the pool? _____
6. Are expenses of the pool deducted before quoting the yield? Yes No
If no, please explain: _____
7. Is the yield generally in line with the market yields for securities in which you usually invest? Yes No

SECURITY

8. Does the pool disclose safekeeping practices? Yes No
If yes, what are they? _____
9. Is the pool subject to audit by an independent auditor? Yes No
10. Is a copy of the audit available to participants? Yes No
11. Who makes the portfolio decisions? _____
12. How does the manager monitor the credit risk of the securities in the pool?

13. Is the pool monitored by someone on the board or a separate, neutral party external to the investment function to ensure compliance with written policies?

14. Does the pool have specific policies with regard to repurchase agreements?
Yes No
If yes, what are those policies? _____

15. Does the pool report the portfolios market value? Yes No

16. Does the pool disclose the following about portfolio valuations (check all that apply):
 Frequency with which the portfolio securities are valued
 Method used to value the portfolio (cost, current value, or other method)

17. Are statements for each account sent to participants? Yes No
Do statements show balances, transactions and yield? Yes No

18. How does the pool distribute detailed reports of its holdings?
 Regularly Upon Request Only

FEES

19. Is there a written schedule of administrative costs? Yes No
What are the fees? _____
How often are they assessed? _____
How are they paid? _____
Are there additional fees for wiring funds? _____

20. Are expenses deducted before quoting the yield? Yes No

OPERATIONS

21. Does the pool limit eligible participants? Yes No
What entities are permitted to invest in the pool? _____

22. Does the pool allow multiple accounts and subaccounts? Yes No

23. Is there a minimum or maximum account size? Yes No
If yes, what is minimum/maximum? _____

24. How many transactions are permitted each month? _____

25. Is there a limit on transaction amounts permitted each month? Yes No
What is the minimum and maximum withdrawal amount permitted? _____

What is the minimum and maximum deposit amount permitted? _____

26. Does the pool require one or more day/s notice for deposits and/or withdrawals?
Yes No

27. Is there a cutoff time for deposits and withdrawals? Yes No

If yes, what is it? _____

28. Are the funds 100% withdrawable at any time? Yes No

29. Are there procedures for making deposits and withdrawals? Yes No

What paperwork required, if any? _____

What are the wiring procedures? _____

30. Can an account remain open with zero balance? Yes No

31. Are confirmations sent following transactions? Yes No

Appendix G - LIST OF PRIMARY GOVERNMENT SECURITIES DEALERS

List of the Primary Government Securities Dealers Reporting to the Government Securities Dealers Statistics Unit of the Federal Reserve Bank of New York:

Bank of Nova Scotia, New York Agency
BMO Capital Markets Corp.
BNP Paribas Securities Corp.
Barclays Capital Inc.
Cantor Fitzgerald & Co.
Citigroup Global Markets Inc.
Credit Suisse Securities (USA) LLC
Daiwa Capital Markets America Inc.
Deutsche Bank Securities Inc.
Goldman, Sachs & Co.
HSBC Securities (USA) Inc.
Jefferies LLC
J.P. Morgan Securities LLC
Merrill Lynch, Pierce, Fenner & Smith Incorporated
Mizuho Securities USA Inc.
Morgan Stanley & Co. LLC
Nomura Securities International, Inc.
RBC Capital Markets, LLC
RBS Securities Inc.
SG Americas Securities, LLC
TD Securities (USA) LLC
UBS Securities LLC.
Wells Fargo Securities LLC.

NOTE: This list has been compiled and made available for statistical purposes only and has no significance with respect to other relationships between dealers and the Federal Reserve Bank of New York. Designation of an entity as a primary dealer by the New York Fed in no way constitutes a public endorsement of that entity by the New York Fed, nor should such designation be viewed as a replacement for prudent counterparty risk management and due diligence.

Government Securities Dealers Statistics Unit
Federal Reserve Bank of New York
April 18, 2016



Investment Policy

Approved June 13, 2017
Proposed April 21, 2026

This page intentionally left blank.

TABLE OF CONTENTS

1.0	AUTHORITY	1
2.0	POLICY STATEMENT	1
3.0	SCOPE.....	1
4.0	OBJECTIVES	2
5.0	DELEGATION OF AUTHORITY	2
6.0	STANDARD OF CARE	3
7.0	ETHICS AND CONFLICTS OF INTEREST	3
8.0	AUTHORIZED FINANCIAL DEALERS AND INSTITUTIONS	4
9.0	AUTHORIZED AND SUITABLE INVESTMENTS.....	5
10.0	INVESTMENT POOLS / MUTUAL FUNDS	5
11.0	COLLATERALIZATION.....	6
12.0	SAFEKEEPING AND CUSTODY	6
13.0	DIVERSIFICATION	7
14.0	MAXIMUM MATURITIES.....	7
15.0	INTERNAL CONTROL.....	8
16.0	PERFORMANCE STANDARDS.....	8
17.0	CREDIT DOWNGRADE	98
18.0	REPORTING.....	9
19.0	INVESTMENT POLICY ADOPTION	10
	Appendix A - AUTHORIZED INVESTMENTS.....	11
	Appendix B - SUMMARY OF AUTHORIZED INVESTMENTS:	16
	Appendix C - GLOSSARY OF TERMS.....	17
	Appendix G - LIST OF PRIMARY GOVERNMENT SECURITIES DEALERS	3336

**Las Virgenes Municipal Water District
Investment Policy
Adopted June 13, 2017**

1.0 AUTHORITY

This Investment Policy was adopted by the Board of Directors of the Las Virgenes Municipal Water District at its regular meeting on June 13, 2017. Any modifications to this policy must be approved by the Board of Directors at a duly noticed public meeting.

2.0 POLICY STATEMENT

It is the policy of Las Virgenes Municipal Water District (“District”) to invest public funds in a manner that provides the maximum security and best investment return, while meeting the daily cash flow demands of the District and conforming to laws governing the investment of public funds.

3.0 SCOPE

This Investment Policy applies to all investment activities and financial assets of the District. Funds held by trustees or fiscal agents are excluded from this policy; however, such funds are subject to regulations established by the State of California. Funds subject to this policy are accounted for in the District’s audited ~~Comprehensive~~ Annual Comprehensive Financial Report (CAACFR).

3.1 Funds Covered by this Policy:

- A. Potable Water
- B. Recycled Water
- C. Sanitation
- D. Rate Stabilization
- E. Internal Services
- F. Insurance Reserve
- G. Joint Powers Authority
- H. Any new fund created by the District unless specifically exempted.

3.2 Funds Excluded From This Policy:

- A. Pension Funds
- B. Other Post-Employment Benefit Funds
- C. Funds related to debt issues controlled by specific provisions of the issuance documents
- D. Deferred compensation program funds

The District ~~commingles pools~~ its funds to maximize investment earnings and increase efficiencies for investment pricing, safekeeping, and administration. Investment income is allocated to the various funds proportionally and in accordance with Generally Accepted Accounting Principles (GAAP).

4.0 OBJECTIVES

The primary objectives, in priority order, of the District's investment activities shall be:

4.1 **Safety:** Safety of principal is the foremost objective of the investment program. Investments of the District shall be undertaken in a manner that seeks to ensure the preservation of capital in the overall portfolio. To attain this objective, the District will diversify its investments in a manner that reduces credit and duration risks. Also, the District will invest funds among a variety of securities offering independent returns and financial institutions.

4.2 **Liquidity:** The District's investment portfolio will remain sufficiently liquid to enable the District to meet all operating requirements that may be reasonably anticipated.

4.3 **Return on Investment:** The District's Investment Policy shall be designed with the objective of attaining a benchmark rate of return throughout budgetary and economic cycles, commensurate with the District's investment risk constraints and the cash flow characteristics of the portfolio in a manner that reduces interest rate risk.

5.0 DELEGATION OF AUTHORITY

The Treasurer is a member of the Board of Directors and responsible for the investments. Daily management responsibility for the investment program is delegated to a Deputy Treasurer, normally the Assistant General Manager or Director of Finance and ~~Administration~~Technology. The Deputy Treasurer shall establish written procedures for the operation of the investment program consistent with this Investment Policy. Procedures should include reference to safekeeping, wire transfer agreements, banking service contracts and collateral/depository agreements. Such procedures shall include explicit delegation of authority to persons responsible for investment transactions.

No person may engage in an investment transaction except as provided under the terms of this policy and the procedures established by the Deputy Treasurer. The Deputy Treasurer shall establish a system of controls to regulate the activities of subordinate designees.

Unless otherwise specifically designated by the District’s Board of Directors, the only officials authorized to undertake investment transactions on behalf of the District are the:

- Treasurer (Board Member)
- Deputy Treasurer
- Deputy Treasurer Designee(s)

Further, no person may engage in an investment transaction except as provided under the terms of the District’s Investment Policy.

6.0 STANDARD OF CARE

In compliance with California Government Code Section 53600.3, the standard of care to be used by investment officials shall be the “prudent investor” standard and applied in the context of managing an overall portfolio. Investment officers acting in accordance with written procedures and the Investment Policy and exercising due diligence shall be relieved of personal liability for an individual security’s credit risk or market price changes, provided deviations from expectations are reported in a timely fashion and appropriate action is taken to control adverse developments.

The “prudent investor” standard states that:

“When investing, reinvesting, purchasing, acquiring, exchanging, selling, or managing public funds, a trustee shall act with care, skill, prudence, and diligence under the circumstances then prevailing, including, but not limited to, the general economic conditions and the anticipated needs of the agency, that a prudent person acting in a like capacity and familiarity with those matters would use in the conduct of funds of a like character and with like aims, to safeguard the principal and maintain the liquidity needs of the agency.”¹

7.0 ETHICS AND CONFLICTS OF INTEREST

The Treasurer, Deputy Treasurer and other employees involved in the investment process shall refrain from personal business activity that could conflict with proper execution of the investment program or which could impair their ability to make impartial investment decisions.

The Treasurer, Deputy Treasurer and other employees involved in the investment process shall disclose any material interests in financial institutions with which they conduct business. They shall further disclose any personal financial/investment positions that could be related to the performance of the investment portfolio and shall not undertake personal investment transactions through the same institution with whom business is conducted on behalf of the District.

The Treasurer, Deputy Treasurer and all District staff with delegated authority for any aspect of the investment process are required to file annual disclosure statements as required by the California Fair Political Practices Commission ("FPPC"), including Forms A-1 and A-2. During the course of the year, if an event subject to disclosure could impair the ability of the Treasurer, Deputy Treasurer or others to make impartial decisions, the Board of Directors will be notified in writing by the General Manager within 10 days of the event.

8.0 AUTHORIZED FINANCIAL DEALERS AND INSTITUTIONS

The District shall transact business only with banks, savings and loans, and registered investment securities dealers. The purchase of any investment, other than those purchased directly from the issuer, shall be purchased either from an institution licensed by the State as a **broker/dealer**, as defined in Section 25004 of the Corporations Code, who is a member of the National Association of Securities Dealers, a member of a Federally regulated securities exchange, a National or State-Chartered Bank, a Federal or State Association (as defined by Section 5102 of the Financial Code), or a brokerage firm designated as a **primary dealer** by the **Federal Reserve Bank**. In addition, a list shall also be maintained by the Deputy Treasurer of approved security broker/dealers who are authorized to provide investment services in California. The District may only conduct business with entities considered "primary" or "regional" dealers that qualify under Securities and Exchange Commission Rule 15C3-1 (uniform net capital rule).

The Deputy Treasurer and his/her assigned staff shall investigate all institutions that wish to do business with the District, in order to determine if they are adequately capitalized, make markets in securities appropriate to the District's needs, and agree to abide by the conditions set forth in this Investment Policy. All financial institutions and broker/dealers that desire to become qualified bidders for investment transactions must provide the District with the following:

- Current audited financial statements;
- Proof of FINRA certification;
- Proof of National Association of Security Dealers (NASD) certification;
- Proof of California registration;
- Completed District questionnaire - Appendix "D" or Appendix "E";
- Evidence of adequate insurance coverage; and
- Certification of having read, understood, and agreed to comply with the District's Investment Policy.

The Deputy Treasurer shall conduct an annual review of the financial condition of all approved financial institutions and broker/dealers in order to determine whether they continue to meet the District's guidelines for qualifications as defined in this section. In addition, the District shall give all approved broker/dealers a copy of the District's Investment Policy on an annual basis. The Deputy Treasurer shall keep current audited annual financial statements on file for each

approved financial institution and broker/dealer with which the District does business with for a minimum period of three years.

9.0 AUTHORIZED AND SUITABLE INVESTMENTS

The District shall only invest in instruments authorized pursuant to Sections 16429.1, 53600 et seq., and 53638 of the Government Code **and** explicitly authorized by the Board subject to the prohibitions set forth in Section 9.1 of this Investment Policy. Appendix A includes a listing of all authorized types of investment securities.

9.1 Prohibited Investments and Transactions

Any investment not specifically authorized in Appendix A is ineligible. The use of derivatives, options, futures or buying on margin is also specifically prohibited. Security transactions shall be conducted on a delivery-versus-payment basis. Securities purchased or acquired by the District shall be held in safekeeping by a third party only pursuant to a custodial agreement as required by Government Code Section 53601.

Also, Government Code Section 53601.6 prohibits local agencies from investing in certain instruments, including inverse floaters, range notes, and mortgage-derived interest only strips. Additionally, the District shall not invest funds in securities that could result in zero interest if held to maturity. Notwithstanding the prohibition above, the District may invest in securities issued or backed by the United States government that could result in zero interest accrual if held to maturity, such as Treasury discount notes.

10.0 INVESTMENT POOLS / MUTUAL FUNDS

The Treasurer shall thoroughly investigate any pooled investment funds, including mutual funds. To accomplish this, a questionnaire (Appendix F) is to be used to evaluate the suitability of the pooled fund. The questionnaire will address the following:

- A description of eligible investment securities, and a written statement of investment policy and objectives;
- A description of interest calculations and how it is distributed, and how gains and losses are treated;
- A description of how the securities are safeguarded (including the settlement processes), and how often the securities are priced and the program is audited;
- A description of who may invest in the program, how often, what size of deposits and withdrawals are allowed;
- A schedule for receiving statements and portfolio listings;
- A description of how reserves and retained earnings are utilized by the pool/fund;
- A fee schedule, and when and how fees are assessed; and
- Whether the pool/fund is eligible for bond proceeds and/or if it will accept such proceeds?

The State of California Local Agency Investment Fund (LAIF) established by Government Code 16429.1 et seq. is explicitly authorized and, therefore, not subject to the provisions of this section.

11.0 COLLATERALIZATION

Pursuant to Government Code Sections 53652 through 53667, the District requires depositories to post certain types and levels of collateral for public funds above the Federal Deposit Insurance Corporation ("FDIC") insurance amounts. The collateral requirements apply to bank deposits, both active (checking and savings accounts) and inactive (non-negotiable time certificates of deposit).

The Treasurer shall require collateralization on two other types of investments: repurchase and reverse agreements. In order to anticipate market changes and provide a level of security for all funds, the collateralization level will be 110% of market value of principal and accrued interest and the value shall be adjusted no less than quarterly. The District requires the collateral to be in the form of U.S. Treasuries or a similar highly liquid instrument.

Collateral will always be held by an independent third party with whom the entity has a current written custodial agreement. A clearly marked evidence of ownership (safekeeping receipt) must be supplied to the District and retained throughout District retention of the investment. The right of collateral substitution is granted.

12.0 SAFEKEEPING AND CUSTODY

To protect against fraud, embezzlement, or losses caused by collapse of individual securities dealers, all securities owned by the District shall be held in safekeeping by the District's custodial bank acting as agent for the District under the terms of a custody agreement. Such custodial bank must be a federal or state association (as defined by Section 5102 of the Financial Code), a trust company or a state or national bank located within this state or with the Federal Reserve Bank of San Francisco or any branch thereof within this state, or with any Federal Reserve bank or with any state or national bank located in any city designated as a reserve city by the Board of Governors of the Federal Reserve System. Collateral for repurchase agreements will be held by a third party custodian under the terms of a Public Securities Association ("PSA") master repurchase agreement.

All security transactions entered into by the District shall be conducted on a delivery-versus-payment (DVP) basis. This procedure ensures that securities are deposited with the third party custodian prior to the release of funds. Securities will be held by a third party custodian designated by the Treasurer or Deputy Treasurer and as evidenced by safekeeping receipts with a written custodial agreement. Pooled Investments, such as LAIF and other local agency pooled investments or money market mutual funds as described in Appendix A are undeliverable and, therefore, not subject to delivery or third party safekeeping. The Deputy Treasurer shall

not be responsible for securities delivered to and received for by a financial institution until they are withdrawn from the financial institution by the Deputy Treasurer or the Deputy Treasurer's designee.

Investment trades, shall be verified against the bank transactions and broker confirmation tickets to ensure accuracy. On a monthly basis, the custodial asset statement shall be reconciled with the month-end portfolio holdings. On an annual basis, the external auditor shall confirm investment holdings.

13.0 DIVERSIFICATION

The District will diversify its investments by security type, institution, and maturity. With the exception of U.S. Treasury securities and authorized pools, no more than 50% of the District's total investment portfolio will be invested in a single security issuer or with a single financial institution. The Treasurer shall to the greatest extent possible:

- Limit investments to avoid over-concentration in securities from a specific issuer or business sector (excluding U.S. Treasury securities),
- Limit investments in securities that have higher credit risks,
- Invest in securities with varying maturities, and
- Continuously invest a minimum amount equal to six months operating budget in readily available funds such as local government investment pools (LAIF), money market funds or overnight repurchase agreements to ensure that appropriate liquidity is maintained in order to meet the District's on-going financial obligations.

13.1 Portfolio Rebalancing

In the event that portfolio percentage constraints are violated due to a temporary imbalance in the portfolio, the District shall hold the affected securities to maturity in order to avoid capital losses. However, if no capital losses would be realized upon sale, the Treasurer, Deputy Treasurer or his/her designee shall consider rebalancing the portfolio after evaluating the expected length of time the portfolio would remain unbalanced. Since portfolio percentage limits are in place to ensure diversification of the District Investment portfolio, a small, temporary imbalance will not significantly impair the strategy.

14.0 MAXIMUM MATURITIES

To minimize the impact of market risk, it is intended that all investments be held to maturity.

The Deputy Treasurer shall match the District's investments with anticipated cash flow requirements known at the time of purchase. The District will not directly invest in securities maturing more than five (5) years from the settlement date, except as specified below. Any investment that is further limited is noted in Appendix A, Authorized Investments. Also,

Appendix B provides a listing of maximum maturities by investment vehicle. The weighted average maturity of the investment portfolio will be based on the anticipated cash flow needs of the District for the upcoming five-year period as monitored through its ten-year financial model. limited to three years or less, exclusive of the funds held in investment pools and mutual funds. Investments may be sold prior to maturity for cash flow, appreciation purposes or in order to limit losses; however, no investment shall be made based solely on earnings anticipated from capital gains.

The Board grants authority to invest in securities with a remaining term in excess of five years as part of the District's overall investment program. Per that authorization, up to 5% of the portfolio value may be invested in U.S. government, Federal Agency, or Municipal securities with remaining maturities at the time of purchase between five and ten years. Per State law, the settlement date of the investment purchase is considered the start date of the remaining term to maturity. Further maturity limitations per State Code are shown in Appendix A.

15.0 INTERNAL CONTROL

The Deputy Treasurer shall ensure that all investment transactions comply with the District's Investment Policy and establish internal controls that are designed to prevent losses due to fraud, negligence or third-party misrepresentation. These controls shall be designed to avoid collusion; ensure separation of duties and administrative controls; maintain separation of transaction authority from accounting and record keeping; provide custodial safekeeping; delegate authority clearly; ensure management approval and review of investment transactions; provide specific limitations regarding securities loss and remedial action; document investment transactions and strategies; and monitor investment performance results.

The Deputy Treasurer shall establish an annual process of independent review by an external audit firm. The external auditor shall review the management of the District's investment program in terms of compliance with the internal controls previously established.

The external auditor, serving as an independent reviewer, will review and verify the District's investment activity, holdings and compliance with this Investment Policy on an annual basis and submit a report to the District's Board of Directors relating thereto.

16.0 PERFORMANCE STANDARDS

The investment portfolio shall be designed with the objective of obtaining a rate of return throughout budgetary, economic, or weather cycles, commensurate with the investment risk constraints and cash flow needs. The District's investment portfolio, exclusive of investment pools and mutual funds, shall utilize the three-year Treasury note as its benchmark. It is understood that due to the District's policy to hold investments to maturity, short-term yields will lag the direction of the three-year Treasury note in changing interest rate environments.

17.0 CREDIT DOWNGRADE

If a security is downgraded below the minimum credit risk criteria specified in the Investment Policy, the Deputy Treasurer shall evaluate the downgrade and bring their evaluation back to the Treasurer and General Manager to evaluate and decide what action to take: continue to monitor and hold through maturity or sell the security on the secondary market.

18.0 REPORTING

The District's Investment Policy shall be reviewed on an annual basis by the Treasurer, Deputy Treasurer, and General Manager with recommendations for changes, if any, made to the Board of Directors.

The District shall maintain a complete and accurate record of all investment transactions.

18.1 Monthly Reports: The Deputy Treasurer shall prepare and submit a monthly investment report of funds directly controlled and managed by the District, including a detailed listing of all investment transactions opened and closed during a reporting period or, if none, a statement to that effect. The report shall be submitted monthly to the Board of Directors.

Each investment report shall be submitted within 45 days following the end of the period covered by the report and must also include certification by the General Manager that investment actions executed since the last report are in compliance with the Investment Policy or state areas of non-compliance; and the District will meet its expenditure obligations for the next six months or state why sufficient money shall, or may, not be available as required by law.

Schedules in the monthly report should include the following:

- The type of investment, name of the issuer, date of maturity, the par value, book value, yield to maturity or yield to call, and cost of all funds invested and subject to this policy;
- Coupon, discount or earnings rate;
- Percentage of the portfolio represented by each investment category; and
- The market value with the source of the market valuation for all securities held by the District, and under management of any outside party that is not also a local agency or the State of California Local Agency Investment Fund.

18.2 Quarterly Report: Within 30 days of the end of each quarter, the Deputy Treasurer shall prepare and submit a quarterly investment report to the Board that includes the information required in the monthly investment report, plus the following additional information:

- A description of any investments, including loans and security lending programs, that are under the management of contracted parties;
- A description of the compliance with the statement of Investment Policy, or manner in

- which the portfolio is not in compliance;
- A statement denoting the District's ability to meet its expenditure requirements for the next six months, or an explanation as to why sufficient money shall, or may, not be available;
- A benchmark comparison;
- A statement of cash and investments held and compliance with adopted reserve policies; and

- A narrative analysis with supporting graphs and/or charts that provide information on performance of the portfolio, as well as general economic and operational trends affecting the portfolios size and/or performance.

The investment portfolio will be managed in accordance with the parameters specified within this policy and monitored and evaluated by the Deputy Treasurer and his/he designated employees involved in the investment process.

19.0 INVESTMENT POLICY ADOPTION

The District's Investment Policy shall be adopted by the Board of Directors. The policy shall be reviewed at least annually to ensure its consistency with the overall objectives of preservation of principal, liquidity, and return on investment, and its relevance to current law, financial and economic trends, and to meet the needs of the District. Any modifications made hereto must be approved by the Board of Directors.

Appendix A - AUTHORIZED INVESTMENTS

1. **UNITED STATES TREASURIES:**

United States Treasury notes, bonds, bills, or certificates of indebtedness, or those for which the faith and credit of the United States are pledged for the payment of principal and interest.

There is no limit as to the amount of the investment portfolio that may be invested in United States Treasury notes. Maximum maturity is five years from the settlement date.

2. **FEDERAL AGENCIES:**

Obligations issued by the United States Government Agencies, such as the Federal Farm Credit Bank System (FFCB), the Federal Home Loan Bank Board (FHLB), the Federal National Mortgage Association (FNMA), Federal Home Loan Mortgage Corporation (FHLMC), the Tennessee Valley Authority (TVA), or obligations, participation, or other instruments of, or issued by a federal agency or a United States government-sponsored enterprise.

There is no limit as to the amount of the investment portfolio that may be invested in federal agencies. Maximum maturity is five years from the settlement date.

3. **STATE BONDS:**

Registered state warrants, treasury notes or bonds of this state and any of the 50 states and the District of Columbia, including bonds payable solely out of the revenues from a revenue-producing property owned, controlled, or operated by the state or by a department, board, agency, or authority of the state. The long-term ratings of such bonds should have at least AA- by Standard and Poor's (S&P), AA- by Fitch or Aa~~3~~⁴ by Moody's, or the short-term ratings should have at least A-1 by S&P, and P-1 by Moody's.

There is no limit as to the amount of the investment portfolio that may be invested in state bonds. Maximum maturity is five years.

4. **LOCAL AGENCY BONDS:**

Bonds and notes issued by local agencies (cities, counties, special districts, or schools) of the United States, including bonds payable solely out of the revenues from a revenue-producing property owned, controlled, or operated by the local agency, or by a department, board, agency, or authority of the local agency, such as Las Virgenes Municipal Water District. The maturity of such bonds or notes should not exceed five years from the date of purchase. The long-term ratings of such bonds should be

investment grade (at least AA- by Standard and Poor's (S&P), KBRA or Fitch or Aa~~3~~⁴ by Moody's, or the short-term ratings should have at least A-1 by S&P, and P-1 by Moody's).

There is no limit as to the amount of the District's portfolio may be invested in local agency bonds. Maximum maturity is five years.

5. **LOCAL GOVERNMENT INVESTMENT POOLS:**

Local government investment pools, that adhere to the California Government Code parameters for eligible investments.

A. LAIF:

State managed Local Agency Investment Fund ("LAIF") pursuant to Government Code Section 16429.1 and Resolution No. 01-04-2291 of the Las Virgenes Municipal Water District.

The maximum amount an agency may invest in LAIF is \$65,000,000 pursuant to the LAIF policy.

B. Local Agency Pooled Investment Funds: Other local agency pooled investment funds that invest pursuant to California Government Code Section 53601 or 53635, as authorized by the Board.

No more than 25 percent of the District's total portfolio value may be invested in other local agency pooled investment funds.

6. **REPURCHASE/REVERSE REPURCHASE AGREEMENTS:**

a.) Investments in repurchase agreements or reverse repurchase agreements of any securities authorized by this section, so long as the agreements are subject to this subdivision, including, the delivery requirements specified in this section. All transactions in repurchase agreements or reverse repurchase agreements shall require a master repurchase agreement executed by the contra-party.

b.) Investments in repurchase agreements may be made, on any investment authorized in this section, when the term of the agreement does not exceed 30 days. The market value of securities that underlies a repurchase agreement must be valued at ~~110~~¹⁰² percent or greater of the funds borrowed against those securities and the value shall be adjusted no less than quarterly.

- c.) Investments in reverse repurchase agreements or similar investments in which the District sells securities prior to purchase, may only be made upon prior approval of the Board of Directors and with a maximum maturity of 30 days.
- d.) (1) "Repurchase agreement" means a purchase of securities by the District pursuant to an agreement by which the counter-party seller will repurchase the securities on or before a specified date and for a specified amount and the counter-party will deliver the underlying securities to the District by book entry, physical delivery, or by third party custodial agreement. The transfer of underlying securities to the counter-party bank's customer book-entry account may be used for book-entry delivery.
- (2) "Securities," for purpose of repurchase under this subdivision, 4 means securities of the same issuer, description, issue date, and maturity.
- (3) "Reverse repurchase agreement" means a sale of securities by the District pursuant to an agreement by which the District will repurchase the securities on or before a specified date and includes other comparable agreements.
- (4) For purposes of this section, the base value of the District's pool portfolio shall be that dollar amount obtained by totaling all cash balances placed in the pool by all pool participants, excluding any amounts obtained through selling securities by way of reverse repurchase agreements or other similar borrowing methods.
- (5) For purposes of this section, the spread is the difference between the cost of funds obtained using the reverse repurchase agreement and the earnings obtained on the reinvestment of the funds.
- (6) Repurchase agreements and reverse repurchase agreements shall only be made with primary dealers of the Federal Reserve Bank of New York.

Repurchase agreements may not exceed 25 percent of the District's investment portfolio value. Reverse repurchase agreements may not exceed 10 percent of the District's investment portfolio value.

7. **MONEY MARKET MUTUAL FUNDS:**

Shares of beneficial interest issued by diversified management companies (otherwise known as “mutual funds”), as defined in Section 23701 of the Revenue and Taxation Code, investing in the securities and obligations as authorized by subdivisions (1) to (12), inclusive, of this section and that comply with the investment restrictions of Article 1 (commencing with Section 53600) and Article 2 (commencing with Section 53630). To be eligible for investment pursuant to this subdivision, these companies shall either:

a) Attain the highest ranking or the highest letter and numerical rating provided by not less than two of the three largest nationally recognized rating services.

b) Commission with not less than five years' experience investing in the securities and obligations as authorized by this Investment Policy, inclusive, and with assets under management in excess of five hundred million dollars (\$500,000,000).

The purchase price of shares of beneficial interest purchased pursuant to this subdivision shall not include any commission that these companies may charge.

The purchase of money market mutual funds shall not exceed 20 percent of the District's total portfolio value; however, no more than 10 percent of the District's investment portfolio value may be invested in shares of beneficial interest of any one money market mutual fund.

8. **CERTIFICATES OF DEPOSIT:**

A. Negotiable, non-negotiable, and placement service certificates of deposits issued by a nationally or state-chartered bank or a state or federal association (as defined by Section 5102 of the Financial Code) or by a state-licensed branch of a foreign bank. The issuing firm should have been in existence for at least five years.

1. Federally insured negotiable Certificates of Deposits up to \$250,000.

2. Certificates of Deposit that are fully collateralized. To collateralize such deposits, an institution shall maintain in the collateral pool securities having a market value of at least 10% in excess of the total amount deposited. Real estate mortgages may not be accepted as collateral. The maximum term for deposits shall be five years. In general, the issuer must have a minimum tier one risk-based capital ratio of 6% as determined by the FDIC and their operation must have been profitable during their last reporting period.

The term of a Certificate of Deposit shall not exceed 5 years from the settlement date. Purchases of all types of certificates of deposit may not exceed 25 percent of the District's portfolio value which may be invested pursuant to this section.

9. **PLACEMENT SERVICE DEPOSITS** - Service that allows a local agency to purchase in excess of \$250,000 in deposits, placing monies with other institutions while maintaining FDIC insurance. Placement service deposits may not exceed 25 percent of the District's investment portfolio value.
10. **COMMERCIAL PAPER** – An unsecured, short-term debt instrument issued by corporations typically used to finance short-term liabilities. Terms cannot exceed 270 days except for asset-backed commercial paper with terms up to 397 days. Commercial paper may not exceed 5 percent of the District's portfolio.
11. **CORPORATE NOTES** - A debt security issued by a corporation to raise capital for projects, acquisitions, or operations maturing in five years or less.
12. **SUPRANATIONAL OBLIGATIONS** – U.S. dollar denominated debt issued or guaranteed by international organizations such as the International Bank for Reconstruction and Development (IBRD) (aka World Bank), International Finance Corporation (IFC), Inter-American Development Bank (IADB)

Appendix B - SUMMARY OF AUTHORIZED INVESTMENTS:

Authorized Investments	District Policy Legal Limit (% or \$)	Maximum Maturity Constraints	Limits
United States Treasuries	Unlimited	5 years	None
U.S. Agencies	Unlimited	5 years	None
State Bonds	Unlimited	5 years	Rated AA-
Local Agency Bonds	Unlimited	5 years	Rated AA-
<u>LAIF/Other Local Agency Investment Pools</u>	<u>\$65,000,000⁷⁵,000,000</u>	N/A	<u>Limited to 15 transactions per month, per State policy Pools subject to Board approval and statutory limits.</u>
<u>Local Agency Pooled Investments</u>	<u>25%</u>	<u>N/A</u>	<u>Prior Board of Directors approval required</u>
Voluntary Investment Fund	Unlimited	N/A	None
County Pooled Investment Fund	Unlimited	N/A	None
Repurchase Agreements	25%	30 days	Requires a Master Repurchase agreement, market value of underlying securities must be greater than <u>110⁰²%</u>
Reverse Repurchase Agreements	10%	30 days	Prior Board of Directors approval required
Money Market Mutual Funds	20%	N/A	No more than 10% will be invested in any one mutual fund
Non-Negotiable Certificates of Deposit	25%	5 years	None
Negotiable Certificates of Deposit	25%	5 years	All CDs over \$250,000 must be collateralized at 110%.
Placement Service CD	25%	5 years	None
Placement Service Deposits	10%	5 years	None
<u>Commercial Paper</u>	<u>5%</u>	<u>397 days or less</u>	<u>Debt, other than commercial paper must be rated A or higher and commercial paper must be rated A-1 or higher</u>
<u>Corporate Notes</u>	<u>5%</u>	<u>5 years</u>	<u>Must be rated AA or higher</u>
<u>Supranational Obligations</u>	<u>10%</u>	<u>5 years</u>	<u>Must be rated AA or higher</u>

Appendix C - GLOSSARY OF TERMS

ACCRUED INTEREST: The interest owed to the seller of a coupon bearing issue from the last coupon date up to the sale date.

AGENCIES: Federal agency securities and/or Government-sponsored enterprises.

COMPREHENSIVE ANNUAL COMPREHENSIVE FINANCIAL REPORT (CAACFR) The official annual report for Las Virgenes Municipal Water District. It includes the presentation of required financial

ASKED: The price at which securities are offered.

BANKERS' ACCEPTANCE (BA): A draft of bill or exchange accepted by a bank or trust company. The accepting institution guarantees payment of the bill, as well as the issuer-evidencing a loan created by the accepting bank.

BASIS POINT: 1/100 of one percent (decimally, .0001)

BENCHMARK: A comparative base for measuring the performance or risk tolerance of the investment portfolio. A benchmark should represent a close correlation to the level of risk and the average duration of the portfolio's investments.

BID: The price offered by a buyer of securities. (When you are selling securities, you ask for a bid.) See OFFER.

BROKER: A broker brings buyers and sellers together for a commission.

CALLABLE BOND: A bond that can be bought back from a holder by the issuer at a specific price after a specific date prior to the maturity date.

CERTIFICATE OF DEPOSIT (CD): A time deposit with a specific maturity evidenced by a certificate. Large-denomination CD's are typically negotiable.

CMO (COLLATERALIZED MORTGAGE OBLIGATION): Mortgage-backed bond that separates mortgage pools into short-, medium-, and long-term portions.

COLLATERAL: Securities, evidence of deposit, or other property that a borrower pledges to secure repayment of a loan. Also refers to securities pledged by a bank to secure deposits of public monies.

COMMERCIAL PAPER (CP): An unsecured promissory note issued by a corporation. Maturity may not exceed 270 days. Usually sold in discount form.

~~**COMPREHENSIVE ANNUAL FINANCIAL REPORT (CAFR)** The official annual report for Las Virgenes Municipal Water District. It includes the presentation of required financial~~

statements in conformity with GAAP. It also includes supporting schedules necessary to demonstrate compliance with finance-related legal and contractual provisions, extensive introductory material, and a detailed Statistical Section.

COUPON: a) The annual rate of interest that a bond's issuer promises to pay the bondholder on the bond's face value. b) A certificate attached to a bond evidencing interest due on a payment date.

DEALER: A dealer, as opposed to a broker, acts as a principal in all transactions buying and selling for his own account.

DEBENTURE: A bond secured only by the general credit of the issuer.

DEFAULT: The failure of a debtor to make timely payments of interest and principal as they come due or to meet some other provision of a bond indenture.

DELIVERY VERSUS PAYMENT (DVP): There are two methods of delivery of securities: delivery versus payment and delivery versus receipt. Delivery versus payment is delivery of securities with an exchange of money for the securities. Delivery versus receipt is delivery of securities with an exchange of a signed receipt for the securities.

DERIVATIVE: (1) Financial instruments whose return profile is linked to, or derived from, the movement of one or more underlying index or security, and may include a leveraging factor, or (2) financial contracts based upon notional amounts whose value is derived from a underlying index or security (interest rates, foreign exchange rates, equities or commodities).

DISCOUNT: The difference between the cost price of a security and its maturity when quoted at a lower than face value. A security selling below original offering price shortly after sale also is considered to be at a discount.

DISCOUNTED SECURITIES: Non-interest bearing money market instruments that are issued at a discount and redeemed at maturity for full face value, e.g. U.S. Treasury Bills.

DIVERSIFICATION: Dividing investment funds among a variety of securities offering independent returns.

DURATION: A measure of the sensitivity of the price of a fixed income security to interest rate changes.

FEDERAL CREDIT AGENCIES: Agencies of the Federal government set up to supply credit to various classes of institutions and individuals, e.g., S&L's, small-business firms, students, farmers, farm cooperatives, and exporters.

FEDERAL DEPOSIT INSURANCE CORPORATION (FDIC): A federal agency that insures bank deposits, currently up to \$250,000 per deposit.

FEDERAL FUNDS RATE: The rate of interest at which Fed funds are traded. This rate is currently pegged by the Federal Reserve through open-market operations.

FEDERAL HOME LOAN BANKS (FHLB): Government sponsored wholesale banks (currently 12 regional banks) that lend funds and provide correspondent banking services to member commercial banks, thrift institutions, credit unions, and insurance companies. The mission of the FHLBs is to liquefy the housing related assets of its members who must purchase stock in their district Bank.

FEDERAL NATIONAL MORTGAGE ASSOCIATION (FNMA): FNMA, like GNMA was chartered under the Federal National Mortgage Association Act in 1938. FNMA is a federal corporation working under the auspices of the Department of Housing and Urban Development (HUD). It is the largest single provider of residential mortgage funds in the United States. Fannie Mae, as the corporation is called, is a private stockholder-owned corporation. The corporation's purchases include a variety of adjustable mortgages and second loans, in addition to fixed-rate mortgages. FNMA's securities are also highly liquid and are widely accepted. FNMA assumes and guarantees that all security holders will receive timely payment of principal and interest.

FEDERAL OPEN MARKET COMMITTEE (FOMC): Consists of seven members of the Federal Reserve Board and five of the twelve Federal Reserve Bank Presidents. The President of the New York Federal Reserve Bank is a permanent member, while the other Presidents serve on a rotating basis. The Committee periodically meets to set Federal Reserve guidelines regarding purchases and sales of Government Securities in the open market as a means of influencing the volume of bank credit and money.

FEDERAL RESERVE SYSTEM: The central bank of the United States created by Congress and consisting of seven member Board of Governors in Washington, D.C., 12 regional banks and about 5,700 commercial banks that are members of the system.

GOVERNMENT NATIONAL MORTGAGE ASSOCIATION (GNMA or Ginnie Mae): Securities influencing the volume of bank credit guaranteed by GNMA and issued by mortgage bankers, commercial banks, savings, and loan associations, and other institutions. Security holder is protected by full faith and credit of the U.S. Government, Ginnie Mae securities are backed by the FHA, VA or FmHA mortgages. The term "pass-throughs" is often used to describe Ginnie Maes.

INVERSE FLOATER; A structured note in which the coupon increases as rates decline and decrease as rates rise.

IO (INTEREST ONLY): A class of mortgage derivative in which the cash flow consists solely of the interest payments from a CMO.

LIQUIDITY: A liquid asset is one that can be converted easily and rapidly into cash without a substantial loss of value. In the money market, a security is said to be liquid if the spread between bid and asked prices is narrow and reasonable size can be done at those quotes.

LOCAL GOVERNMENT INVESTMENT POOL (LGIP): The aggregate of all funds from political subdivisions that are placed in the custody of the State Treasurer for investment and reinvestment.

MARKET PRICE: In general business, the price agreed upon by buyers and sellers of a product or service, as determined by supply and demand.

MARKET VALUE: The price at which a security is trading and could presumably be purchased or sold.

MASTER REPURCHASE AGREEMENT: A written contract covering all future transactions between the parties to repurchase – reverse repurchase agreements that establishes each party’s rights in the transactions. A master agreement will often specify, among other things the right of the buyer-lender to liquidate the underlying securities in the event of default by the seller-borrower.

MATURITY: The date upon which the principal or stated value of an investment becomes due and payable.

MONEY MARKET: The market in which short-term debt instruments (bills, commercial paper, banker’s acceptances, etc.) are issued and traded.

NEGOTIABLE CERTIFICATES OF DEPOSIT: Large denomination interest bearing deposits with a fixed maturity date that may be sold in the money market.

OFFER: The price asked by a seller of securities. (When you are buying securities, you ask for an offer.) See ASKED and BID.

OPEN MARKET OPERATIONS: Purchases and sales of government and certain other securities in the open market by the New York Federal Reserve Bank as directed by the FOMC in order to influence the volume of money and credit in the economy. Purchases inject reserves into the bank system and stimulate growth of money and credit; sales have the opposite effect. Open market operations are the Federal Reserve’s most important monetary policy tool.

PAR: 1) 100% of the face amount of an issue. 2) The principal amount a holder will receive at the maturity of an issue.

PORTFOLIO: Collection of securities held by an investor.

PREMIUM: 1) The amount by which the market price of an issue exceeds par. 2) The amount in excess of par that an issuer must pay to call in its bonds. 3) In the money market, the rate higher than the norm that one bank must pay to attract CD depositors.

PRIMARY DEALER: A group of government securities dealers who submit daily reports of market activity and positions and monthly financial statements to the Federal Reserve Bank of New York and are subject to its informal oversight. Primary dealers include Securities and Exchange Commission (SEC)-registered securities broker-dealers, banks, and a few unregulated firms.

PRIME RATE: The loan rate for the best customers of a bank.

PRINCIPAL: 1) The dollar cost of an issue excluding accrued interest. 2) The one who takes ownership in a transaction, as opposed to brokering or acting as agent.

PRUDENT PERSON RULE: An investment standard. In some states the law requires that a fiduciary, such as a trustee, may invest money only in a list of securities selected by the custody state-the so-called legal list. In other states the trustee may invest in a security if it is one which would be bought by a prudent person of discretion and intelligence who is seeking a reasonable income and preservation of capital.

QUALIFIED PUBLIC DEPOSITORIES: A financial institution which does not claim exemption from the payment of any sales or compensating use of ad valorem taxes under the laws of this state, which as segregated for the benefit of the commission eligible collateral having a value of not less than its maximum liability and which has been approved by the Public Deposit Protection Commission to hold public deposits.

RATE OF RETURN: The yield obtainable on a security based on its purchase price or its current market price. This may be the amortized yield to maturity on a bond the current income return.

REPURCHASE AGREEMENT (RP OR REPO): A holder of securities sells these securities to an investor with an agreement to repurchase them at a fixed price on a fixed date. The Security “buyer” in effect lends the “seller” money for the period of the agreement, and the terms of the agreement are structured to compensate him for this. Dealers use RP extensively to finance their positions. Exception: When the Fed is said to be doing RP, it is lend money that is, increasing bank reserves.

SAFEKEEPING: A service to customers rendered by banks for a fee whereby securities and valuables of all types and descriptions are held in the bank's vaults for protection.

SECONDARY MARKET: A market made for the purchase and sale of outstanding issues following the initial distribution.

SECURITIES & EXCHANGE COMMISSION: Agency created by Congress to protect investors in securities transactions by administering securities legislation.

SEC RULE 15C3-1: See Uniform Net Capital Rule.

SPREAD: 1) The yield or price difference between the bid and offer on an issue. 2) The yield or price difference between different issues.

STRUCTURED NOTES: Notes issued by Government Sponsored Enterprises (FHLB, FNMA, SLMA, etc.) and Corporations that have imbedded options (e.g., call features, step-up coupons, floating rate coupons, derivative-based returns) into their debt structure. Their market performance is impacted by the fluctuation of interest rates, the volatility of the imbedded options and shifts in the shape of the yield curve.

SWAP: The sale of one issue and the simultaneous purchase of another for some perceived advantage.

TRADE DATE: The date on which the buyer and seller agree to a transaction. The trade date may or may not be the day on which the securities and money changes hands.

TREASURY BILLS: A non-interest bearing discount security issued by the U.S. Treasury to finance the national debt. Most bills are issued to mature in three months, six months, or one year.

TREASURY BONDS: Long-term coupon-bearing U.S. Treasury securities issued as direct obligations of the U.S. Government and having initial maturities of more than 10 years.

TREASURY NOTES: Medium-term coupon-bearing U.S. Treasury securities issued as direct obligations of the U.S. Government and having initial maturities from two to 10 years.

UNIFORM NET CAPITAL RULE: Securities and Exchange Commission requirement that member firms as well as nonmember broker-dealers in securities maintain a maximum ratio of indebtedness to liquid capital of 15 to 1; also called net capital rule and net capital ratio. Indebtedness covers all money owed to a firm, including margin loans and commitments to purchase securities, one reason new public issues are spread among member so underwriting syndicates. Liquid capital includes cash and assets easily converted into cash.

YIELD: The rate of annual income return on an investment, expressed as a percentage.

INCOME YIELD is obtained by dividing the current dollar income by the current market price for the security. (b) **NET YIELD or YIELD TO MATURITY** is the current income yield minus any premium above par or plus any discount from par in purchase price, with the adjustment spread over the period from the date of purchase to the date of maturity of the bond.

17. What transaction documents and reports would we receive? _____

18. What information would you provide to our Treasurer and/or Deputy Treasurer?

19. Describe the precautions taken by your Bank/Savings and Loan to protect the interest of the public when dealing with government agencies as depositors or investors. _____

20. Please provide your Contract of Deposit of Moneys pre-signed and sealed by your institution, as well as, any signature cards that you may require.
21. Please provide your Wiring Instructions: _____

22. Please provide your Bank/Savings and Loan most recent certified financial statement. In addition, an audited financial statement must be provided within 120 days of your fiscal year-end.

- CERTIFICATION -

I hereby certify that I have personally read Las Virgenes Municipal Water District’s (the “District”) Investment Policy and the California Government Codes pertaining to the investments and deposits of the District, and have implemented reasonable procedures and a system of controls designed to preclude imprudent investment activities arising out of transactions conducted between our firm and the District. **I understand however, that our firm is not obligated to monitor the percentage limits on the investments as described in the policy.** All sales personnel will be routinely informed of District investment objectives, horizon, outlook, strategies and risk constraints whenever we are so advised. We pledge to exercise due diligence in informing District Investment Officers of all foreseeable risks associated with financial transactions conducted with our firm. I attest to the accuracy of our responses to your questionnaire.

NOTE: Completion of Questionnaire is only part of District’s Certification process and DOES NOT guarantee that the applicant will be approved to do business with the District.

Signature: _____ Date: _____

Name: _____ Title: _____

Countersigned: _____ Date: _____

Name: _____ Title: _____

14. Which of the above does your firms specialize in Marketing? _____

15. Please identify your most directly comparable Local Agency clients in our geographical area:
Contact Person: _____

Telephone No: _____ Client Since: _____

16. What reports, transactions, confirmations and paper trail would we receive?

17. Please include samples of research reports or market information that your firm regularly provides to local agency clients.

18. What precautions are taken by your firm to protect the interest of the public when dealing with government agencies as investors? _____

19. Have you or your firm been censured or punished by a Regulatory State or Federal Agency for improper or fraudulent activities, related to the sale of securities? Yes No

20. If yes, please explain: _____

21. Attach certified documentation of your capital adequacy and financial solvency. In addition, an audited financial statement must be provided within 120 days of your fiscal year-end.

- CERTIFICATION -

I hereby certify that I have personally read Las Virgenes Municipal Water District’s (the “District”) Investment Policy and the California Government Codes pertaining to the investments and deposits of the District, and have implemented reasonable procedures and a system of controls designed to preclude imprudent investment activities arising out of transactions conducted between our firm and the District. **I understand however, that our firm is not obligated to monitor the percentage limits on the investments as described in the policy.** All sales personnel will be routinely informed of District investment objectives, horizon, outlook, strategies and risk constraints whenever we are so advised. We pledge to exercise due diligence in informing District Investment Officers of all foreseeable risks associated with financial transactions conducted with our firm. I attest to the accuracy of our responses to your questionnaire.

NOTE: Completion of Questionnaire is only part of District’s Certification process and DOES NOT guarantee that the applicant will be approved to do business with the District.

Signature: _____ Date: _____

Name: _____ Title: _____

Countersigned: _____ Date: _____

Name: _____ Title: _____

LAS VIRGENES MUNICIPAL WATER DISTRICT
DEPARTMENT OF FINANCE & ADMINISTRATION TECHNOLOGY

INVESTMENT POOL QUESTIONNAIRE

SECURITIES

1. Does the pool provide a written statement of investment policy and objectives?
Yes No
2. Does the statement contain the following (check all that apply):
 - A description of eligible investment instruments
 - The credit standards of investments
 - The allowable maturity range of investments
 - The maximum allowable dollar weighted average portfolio maturity
 - The limits of portfolio concentration permitted for each type of security
 - The policy of reverse repos
3. Are the changes in the policies communicated to the pool participants?
Yes No

INTEREST

4. Does the pool disclose the following about yield calculations (check all that apply):
 - Methodology is used to calculate interest (simple maturity, yield to maturity, etc.)
 - Frequency of interest payments
 - How interest is paid
 - How gains/losses are reported (factored monthly or only when realized)
5. How often is the yield reported to participants of the pool? _____
6. Are expenses of the pool deducted before quoting the yield? Yes No
If no, please explain: _____
7. Is the yield generally in line with the market yields for securities in which you usually invest? Yes No

SECURITY

8. Does the pool disclose safekeeping practices? Yes No
If yes, what are they? _____
9. Is the pool subject to audit by an independent auditor? Yes No
10. Is a copy of the audit available to participants? Yes No
11. Who makes the portfolio decisions? _____
12. How does the manager monitor the credit risk of the securities in the pool?

13. Is the pool monitored by someone on the board or a separate, neutral party external to the investment function to ensure compliance with written policies?

14. Does the pool have specific policies with regard to repurchase agreements?
Yes No
If yes, what are those policies? _____

15. Does the pool report the portfolios market value? Yes No

16. Does the pool disclose the following about portfolio valuations (check all that apply):
 Frequency with which the portfolio securities are valued
 Method used to value the portfolio (cost, current value, or other method)

17. Are statements for each account sent to participants? Yes No
Do statements show balances, transactions and yield? Yes No

18. How does the pool distribute detailed reports of its holdings?
 Regularly Upon Request Only

FEES

19. Is there a written schedule of administrative costs? Yes No
What are the fees? _____
How often are they assessed? _____
How are they paid? _____
Are there additional fees for wiring funds? _____

20. Are expenses deducted before quoting the yield? Yes No

OPERATIONS

21. Does the pool limit eligible participants? Yes No
What entities are permitted to invest in the pool? _____

22. Does the pool allow multiple accounts and subaccounts? Yes No

23. Is there a minimum or maximum account size? Yes No
If yes, what is minimum/maximum? _____

24. How many transactions are permitted each month? _____

25. Is there a limit on transaction amounts permitted each month? Yes No
What is the minimum and maximum withdrawal amount permitted? _____

What is the minimum and maximum deposit amount permitted? _____

26. Does the pool require one or more day/s notice for deposits and/or withdrawals?
Yes No

27. Is there a cutoff time for deposits and withdrawals? Yes No

If yes, what is it? _____

- 28. Are the funds 100% withdrawable at any time? Yes No
- 29. Are there procedures for making deposits and withdrawals? Yes No
What paperwork required, if any? _____
What are the wiring procedures? _____
- 30. Can an account remain open with zero balance? Yes No
- 31. Are confirmations sent following transactions? Yes No

Appendix G - LIST OF PRIMARY GOVERNMENT SECURITIES DEALERS

List of the Primary Government Securities Dealers Reporting to the Government Securities Dealers Statistics Unit of the Federal Reserve Bank of New York:

Bank of Nova Scotia, New York Agency
BMO Capital Markets Corp.
BNP Paribas Securities Corp.
Barclays Capital Inc.
Cantor Fitzgerald & Co.
Citigroup Global Markets Inc.
Credit Suisse Securities (USA) LLC
Daiwa Capital Markets America Inc.
Deutsche Bank Securities Inc.
Goldman, Sachs & Co.
HSBC Securities (USA) Inc.
Jefferies LLC
J.P. Morgan Securities LLC
Merrill Lynch, Pierce, Fenner & Smith Incorporated
Mizuho Securities USA Inc.
Morgan Stanley & Co. LLC
Nomura Securities International, Inc.
RBC Capital Markets, LLC
RBS Securities Inc.
SG Americas Securities, LLC
TD Securities (USA) LLC
UBS Securities LLC.
Wells Fargo Securities LLC.

NOTE: This list has been compiled and made available for statistical purposes only and has no significance with respect to other relationships between dealers and the Federal Reserve Bank of New York. Designation of an entity as a primary dealer by the New York Fed in no way constitutes a public endorsement of that entity by the New York Fed, nor should such designation be viewed as a replacement for prudent counterparty risk management and due diligence.

Government Securities Dealers Statistics Unit
Federal Reserve Bank of New York
April 18, 2016



State Water Project

Northern Sierra Snow

Water Content values in inches

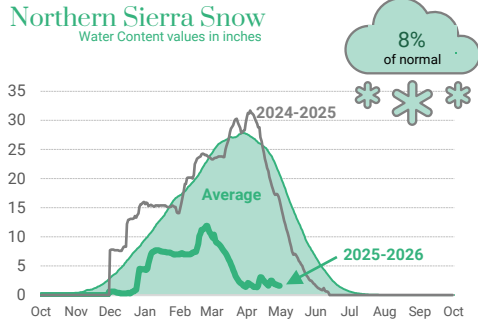

Northern Sierra 8 Station Rain

Values in inches

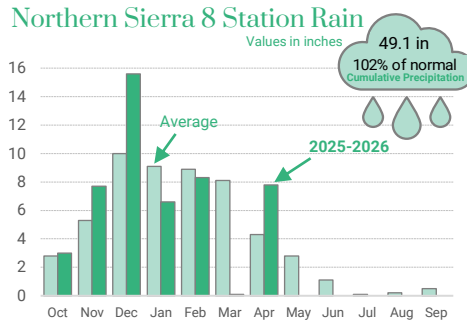

Colorado River

Colorado River Basin Snow

Water Content values in inches

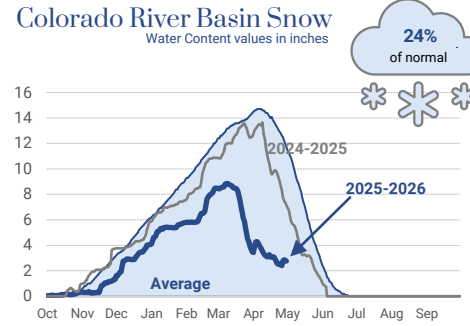

Colorado River Basin Rain

Values in inches

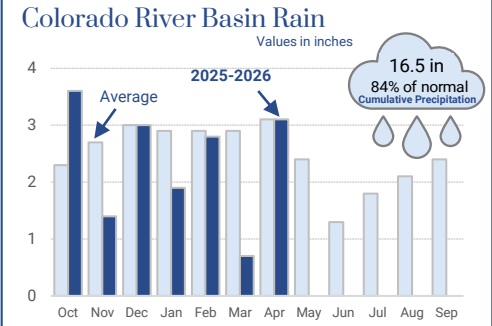

Sacramento River Runoff

Values in million acre-feet

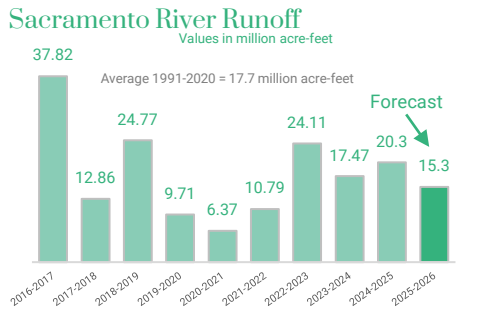

2026 State Water Project Allocation

30%

Current Table A allocation set on January 29, 2026

Lake Mead Elevation Projections

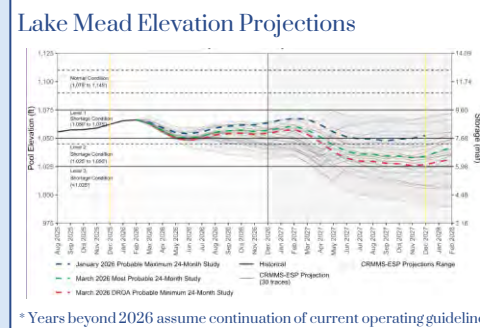

Unregulated Inflow into Lake Powell

Values in million acre-feet

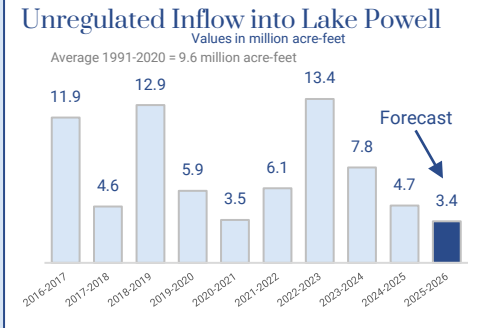

Oroville Reservoir Storage

Values in million acre-feet

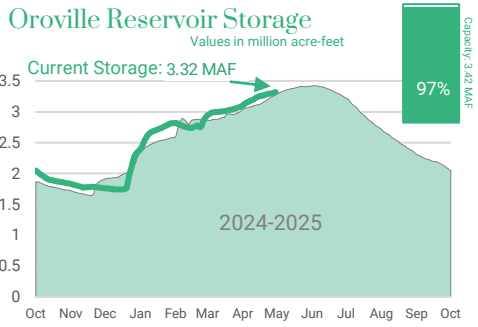

San Luis Reservoir SWP Storage

Values in million acre-feet

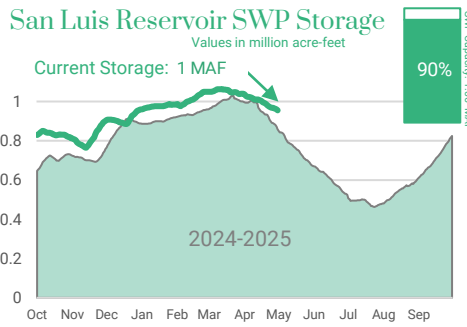

Lake Mead Storage

Values in million acre-feet

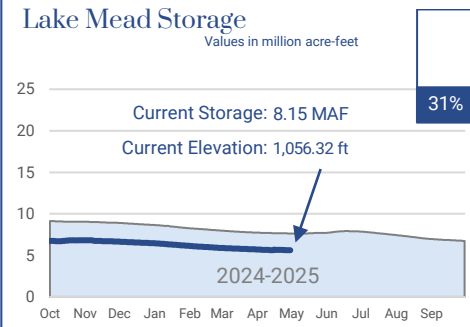

Lake Powell Storage

Values in million acre-feet

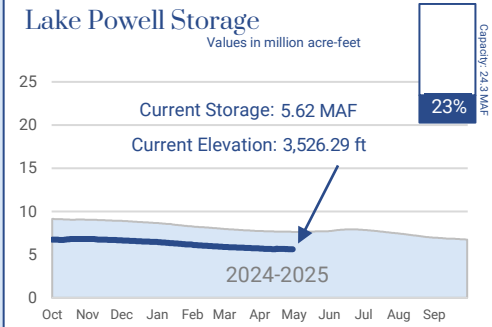

Northern Sierra Precipitation: 8-Station Index, April 29, 2026

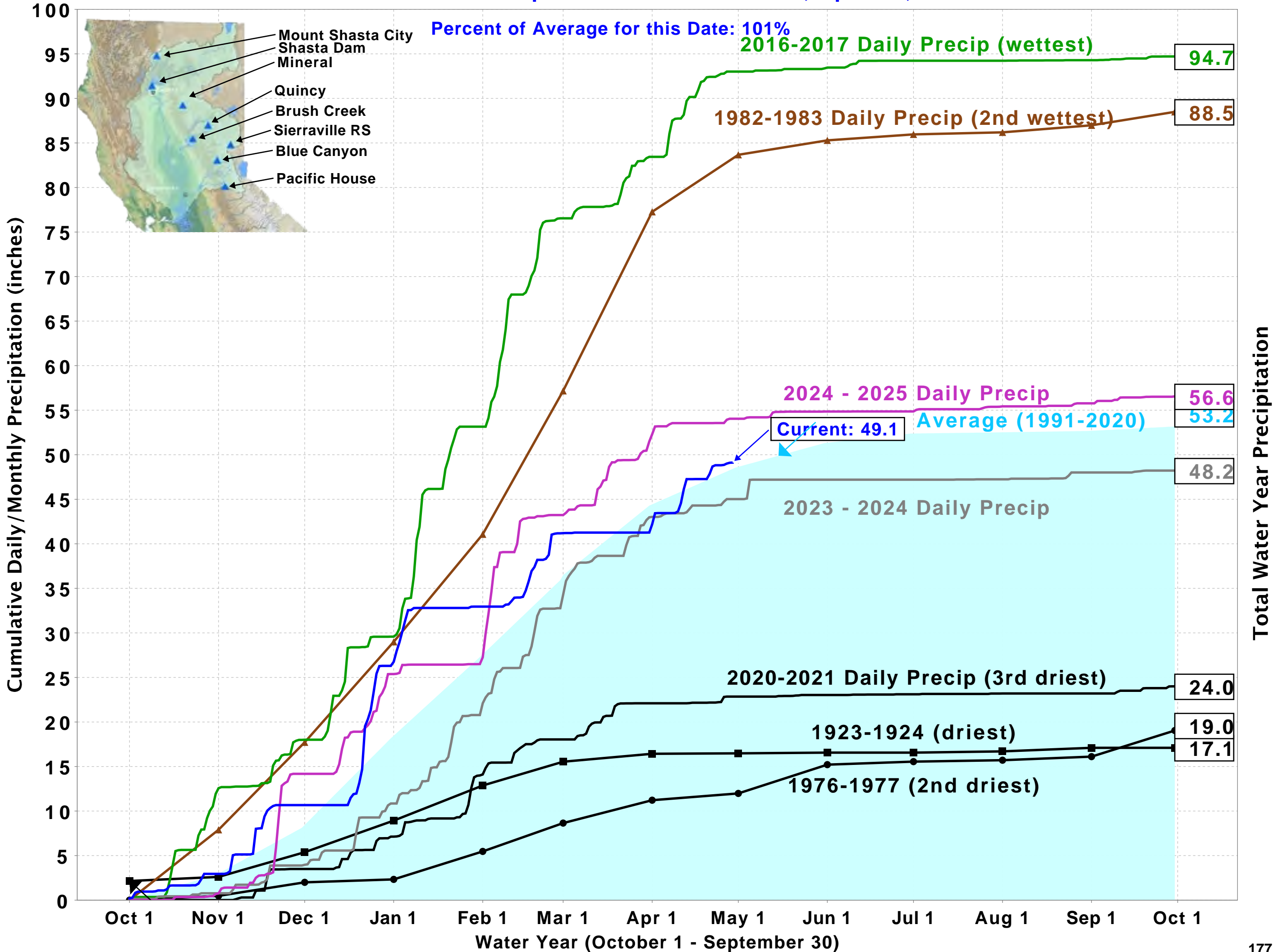

CURRENT CONDITIONS: MAJOR WATER SUPPLY RESERVOIRS:28-APR-2026

Data as of Midnight: 28-Apr-2026

Change Date:

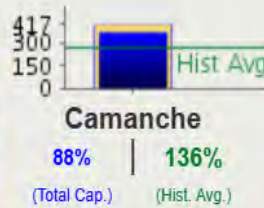
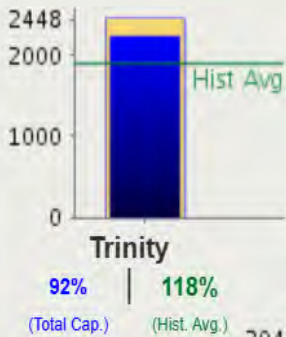
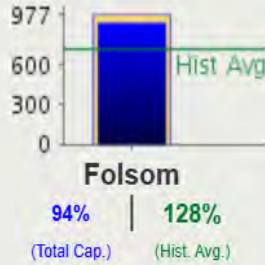
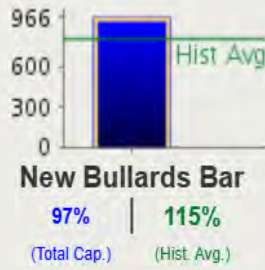
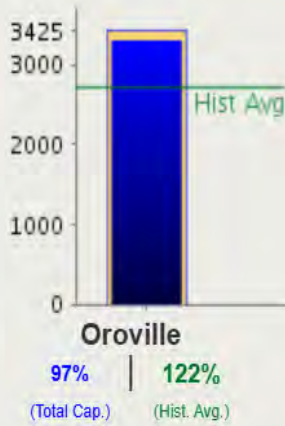
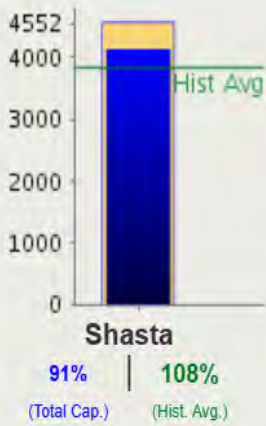

LEGEND

- Blue Bar:** Storage level for date
- Gold Bar:** Total reservoir capacity
- Green Line:** Historic level for date.

% of Capacity | % Hist. Avg.
(Click res. 3 char. code for details)

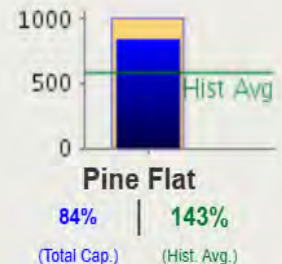
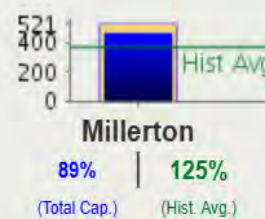
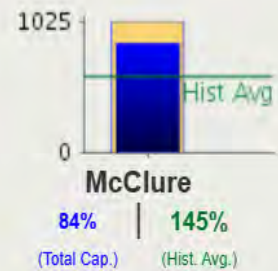
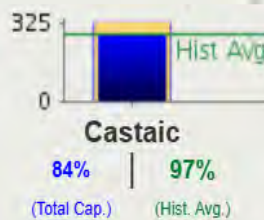
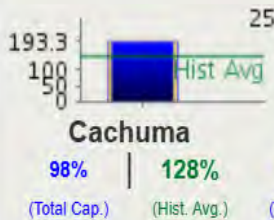
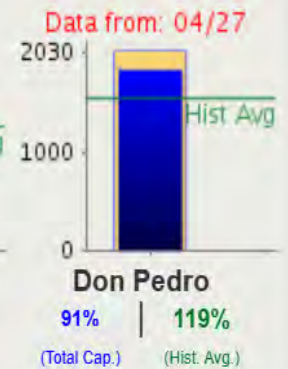
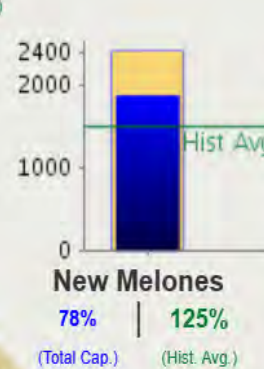
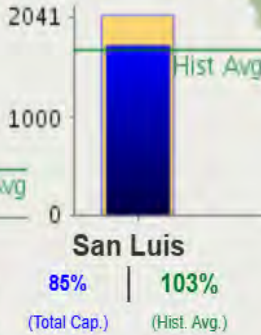
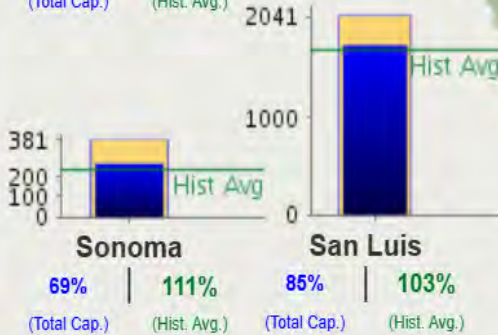

[Click to download printable version of current data.](#)

Report Generated: 29-Apr-2026 8:06 PM

The CSI link has been disabled to zoom in, for the lack of historical data.



STATEWIDE SNOW WATER CONTENT

CURRENT REGIONAL SNOWPACK FROM AUTOMATED SNOW SENSORS

% of April 1 Average / % of Normal for This Date

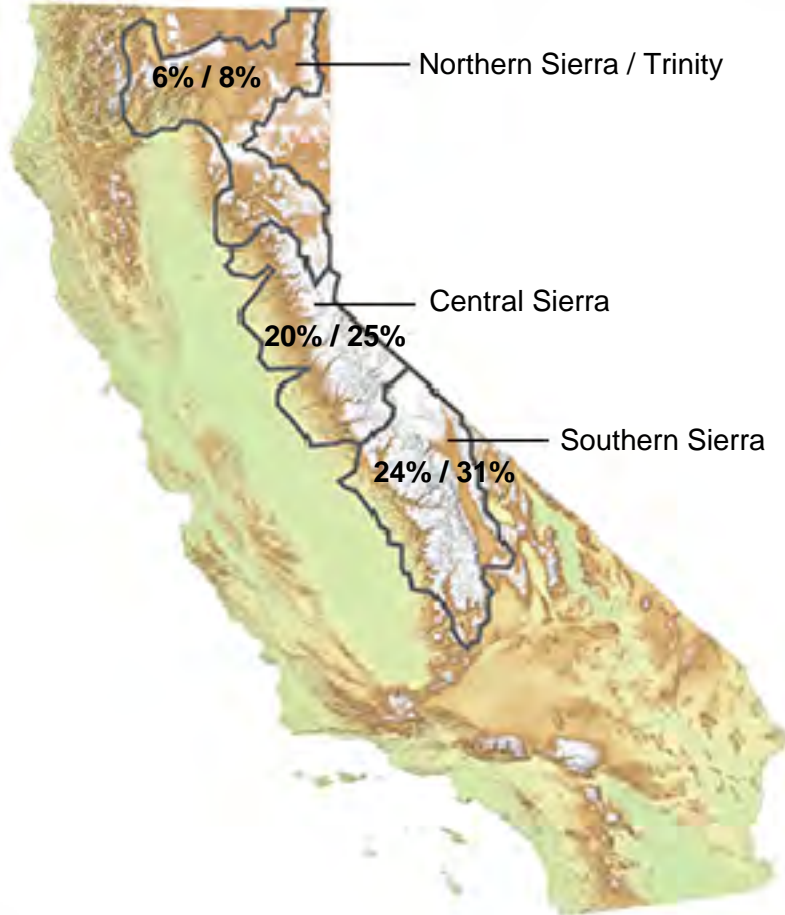

NORTH	
Data as of April 29, 2026	
Number of Stations Reporting	31
Average snow water equivalent (Inches)	1.6
Percent of April 1 Average (%)	6
Percent of normal for this date (%)	8

CENTRAL	
Data as of April 29, 2026	
Number of Stations Reporting	54
Average snow water equivalent (Inches)	5.7
Percent of April 1 Average (%)	20
Percent of normal for this date (%)	25

SOUTH	
Data as of April 29, 2026	
Number of Stations Reporting	25
Average snow water equivalent (Inches)	5.7
Percent of April 1 Average (%)	24
Percent of normal for this date (%)	31

STATE	
Data as of April 29, 2026	
Number of Stations Reporting	110
Average snow water equivalent (Inches)	4.5
Percent of April 1 Average (%)	17
Percent of normal for this date (%)	22

Statewide Average: 17% / 22%

Data as of April 29, 2026





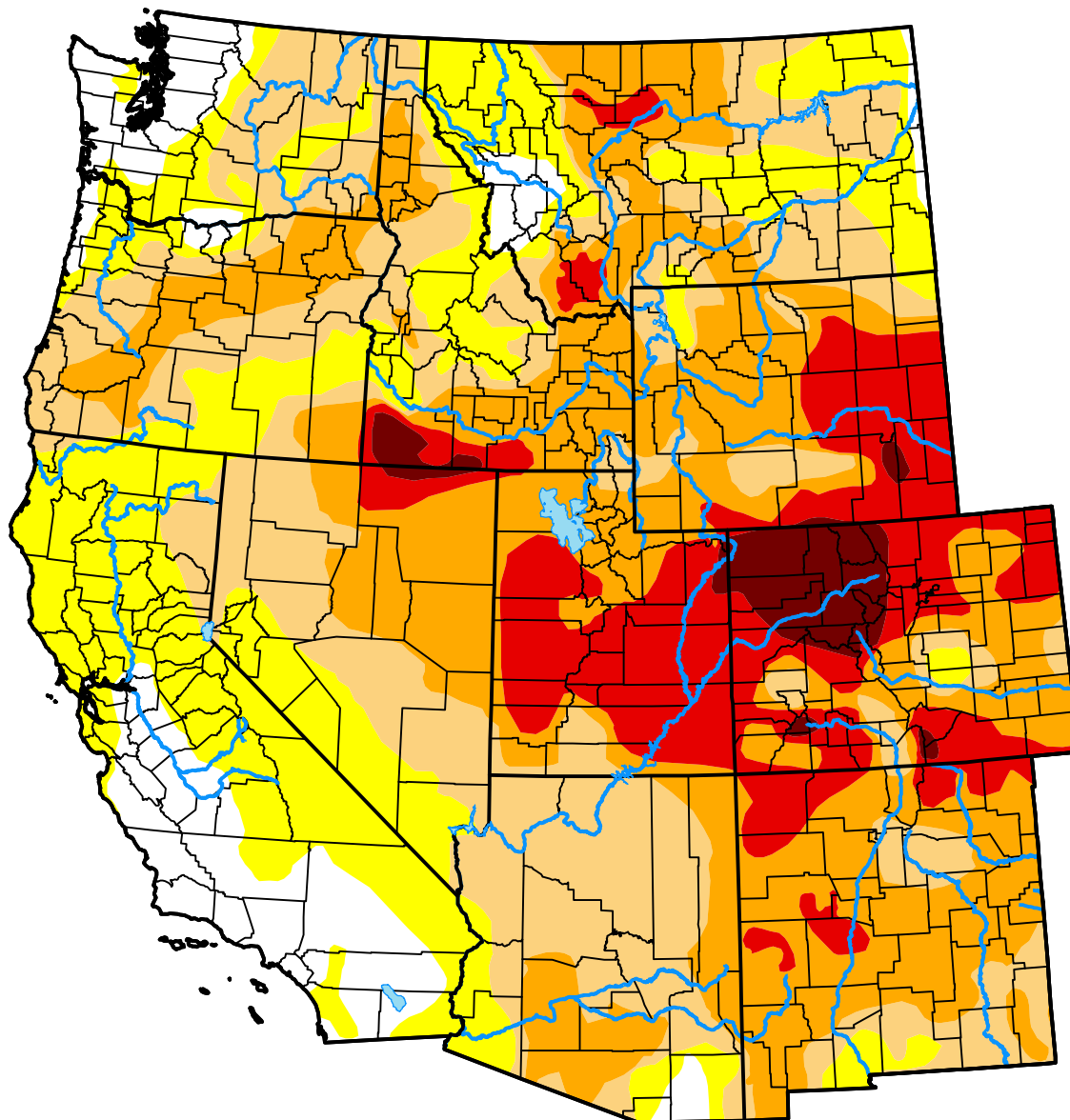

U.S. Drought Monitor

West

April 21, 2026
(Released Thursday, Apr. 23, 2026)
Valid 8 a.m. EDT



Intensity:

-  None
-  D0 Abnormally Dry
-  D1 Moderate Drought
-  D2 Severe Drought
-  D3 Extreme Drought
-  D4 Exceptional Drought

The Drought Monitor focuses on broad-scale conditions. Local conditions may vary. For more information on the Drought Monitor, go to <https://droughtmonitor.unl.edu/About.aspx>

Author:

Brian Fuchs
National Drought Mitigation Center





DATE: May 13, 2026
TO: Board of Directors
FROM: Engineering and Facilities

SUBJECT: Equestrian Tank Rehabilitation Project: Design Award

SUMMARY:

The District maintains a regular inspection and cleaning schedule for its 26 potable water tanks, and inspection reports are utilized for the Tank Condition Assessment and Rehabilitation Program to identify tanks in need of maintenance and prioritize rehabilitation projects. Equestrian Tank was recently identified as requiring rehabilitation.

HDR Engineering, Inc., is a firm with demonstrated experience providing engineering services to the District on water infrastructure projects. Staff recommends that the Board accept the proposal from HDR Engineering, Inc., and authorize the General Manager to execute a professional services agreement, in the amount of \$249,504, for design, bidding, and construction support services for the Equestrian Tank Rehabilitation Project.

RECOMMENDATION(S):

Accept the proposal from HDR Engineering, Inc., and authorize the General Manager to execute a professional services agreement, in the amount of \$249,504, for design, bidding, and construction support services for the Equestrian Tank Rehabilitation Project.

FISCAL IMPACT:

Yes

ITEM BUDGETED:

Yes

FINANCIAL IMPACT:

The cost of the work is \$249,504 with \$146,769 budgeted for CIP Job No. 10651, Equestrian Tank Rehabilitation Project. Additional funding for the work is available for re-appropriation, in the amount of \$102,735, from CIP Job No. 10757, Jed Smith Tank No. 1 and McCoy Tank Rehabilitation Project.

DISCUSSION:

The District operates and maintains a water distribution system that includes 26 potable water storage tanks. The District routinely completes the inspection and cleaning of its 26 potable water tanks, and the resulting inspection reports are utilized for the Tank Condition Assessment and Rehabilitation Program. The goal of the program is to identify tanks in need of maintenance and prioritize the rehabilitation projects accordingly.

Equestrian Tank, located on Glenbridge Road in Westlake Village, is a 4.2-million-gallon underground reservoir built in 1971. The concrete reservoir provides potable water storage for the 1227-foot pressure zone, serving Westlake Village. Since 2004, alkali-silica cracking (ASC) has been observed within the tank. Subsequent inspections have revealed no significant structural distress, but the cracking is present in the columns and pilasters. ASC is caused by a chemical reaction between certain aggregates and cements used in concrete construction, and the concrete degradation is not new to the District.

The District posted a Request for Proposals for the work on February 18, 2026. The scope of work for the rehabilitation of the reservoir includes the following items of work: repair of structural elements including footings, columns, pilasters, and roof; updating site security measures; seismic retrofitting, if necessary; and ancillary improvements as needed to rehabilitate the tank and address the existing ASC.

Two proposals were received for design, bidding, and construction support services. Both firms are well-qualified to complete the design and provide engineering support during construction for the project. Staff thoroughly evaluated the proposals based on project understanding, approach, company resources, cost, and experience. Staff determined HDR's approach to be the most effective and the best value for the District. HDR demonstrated a thorough understanding of the project history and concerns, having prepared five previous structural inspections for the District at the Equestrian Tank in preparation for this project, making them well-suited to conduct this design.

A series of optional tasks were proposed by HDR, totaling \$94,721, for a total proposed fee of \$296,544. These optional tasks include more thorough tank inspection options, additional design based on inspection findings, analysis of the main roof girder, if necessary (if settlement is found during preliminary inspections), and construction inspection services. Staff recommends awarding all optional tasks with the exception of construction inspection, which would be conducted by District staff or under the District's existing on-call inspections contract.

The recommended optional tasks would add \$47,681 to the base proposal cost for a total design award amount of \$249,504. Work on the optional tasks would only occur with prior authorization by District staff.

GOALS:

Construct, Manage and Maintain all Facilities and Provide Services to Assure System Reliability and Environmental Compatibility

Prepared by: John Soderberg, PE, Associate Engineer

ATTACHMENTS:

[HDR Proposal](#)

[HDR Fee Schedule](#)



TECHNICAL PROPOSAL FOR
**EQUESTRIAN TANK
REHABILITATION
PROJECT DESIGN**

2026-RFP-041



March 18,
2026



TABLE OF CONTENTS

SECTION NO.	SECTION TITLE	PAGE NO.
1	Cover Letter	01
2	Project Understanding & Approach	02
3	Project Scope	09
4	Project Team	12
5	Quality Control Process	16
6	Sub-consultant Qualifications	17
7	Project Examples	18
8	Certificate of Professional Liability Insurance	22
9	Schedule of Rates	23
10	Matrix of Tasks/Hours	24
11	Professional Services Agreement	25

APPENDIX	SECTION TITLE	PAGE NO.
A	Resumes	A-1



1 Cover Letter





March 18, 2026

Las Virgenes Municipal Water District
4232 Las Virgenes Rd.
Calabasas, CA 91302
Ph: (310) 660-6207

Submitted via: OpenGov portal

Subject: HDR Proposal for the Equestrian Tank Rehabilitation Project Design, 2026-RFP-041

Dear Selection Committee,

HDR appreciates the opportunity to provide a proposal for this very important project. The Equestrian Trails Tank is a critical facility in the western half of the District’s Main Backbone System, providing gradient support, and vital water storage for daily operations, fire flows, and emergencies.

For several years, there have been concerns regarding the tank’s structural integrity. During repairs to fix beam bearing issues in 2004, cracking of the columns, pilasters, and footings was first observed. These cracks have since been assessed and monitored through a series of float and dry inspections, every few years.

While major distress to the structure has not yet been observed, this cracking will eventually lead to premature rebar corrosion, and should be addressed soon. There is also concern that differential settlement may distress the main girder, which is what happened at a nearly identical facility, the Meadows Reservoir in Thousand Oaks. No one understands these issues better than HDR Project Manager, Dan Ellison, who has been involved in all the Equestrian structural inspections, and led the design of emergency repairs at the Meadows Reservoir.

HDR is ready to design Equestrian’s rehabilitation based on results from previous inspections, but we recommend additional float and dry inspections be conducted first, like the 2017 inspections led by the District. (A dive inspection would not suffice.) The proposed inspections would reduce risks that unexpected conditions during construction will lead to change orders. The proposed inspections can be conducted this Spring, with Morrison Tank and the 5 MG tank at Las Virgenes Reservoir providing backbone system support.

Again, we appreciate the opportunity to provide this proposal and acknowledge Addendum 1 on March 4, 2026 and Addendum 2 on March 17, 2026. Questions may be directed to Dan Ellison, Dan.Ellison@hdrinc.com, (213) 200-5152.

Sincerely,

HDR Engineering, Inc.

Anna Lantin, PE
Sr. Vice President

Dan Ellison, PE, SE
Project Manager

**YOUR PROJECT
WILL BE MANAGED
OUT OF HDR'S
VENTURA OFFICE**

LOCATED AT:
625 E Santa Clara Ave.
Suite 100,
Ventura, CA 93001

Legal Company Information

HDR Engineering ,Inc.
Anna Lantin, PE,
Sr. Vice President/ Authorized
Signatory
350 South Grand Avenue
Suite 2900,
Los Angeles, CA 90071
(714) 730-2300
Anna.Lantin@hdrinc.com

Your Proposal Contact

Dan Ellison, PE, SE
(213) 200-5152
Dan.ellison@hdrinc.com

Key Goals Include:

- ✓ Assess current condition of tank
- ✓ Evaluate risks and alternatives
- ✓ Economically extend the life of the tank
- ✓ Contract drawings that clearly illustrate the work
- ✓ Clear, concise specifications with appropriate unit price items to cover contingencies
- ✓ Accurate opinion of probable cost
- ✓ Support through bid and construction phase



2 Project Understanding & Approach



PROJECT UNDERSTANDING

Structural Concerns at Equestrian Trails Tank

Cracking of the columns and pilasters at Equestrian Trails Tank was first noted in 2004, when the tank was drained for a maintenance project. The source of the cracking was soon determined to be alkali-silica reactive (ASR) aggregate. Since that time, HDR Project Manager, Dan Ellison has performed five structural inspections (2004, 2006, 2010, 2012, and 2017). In these inspections, no significant structural distress has been observed, although substantial cracking is prevalent and concerns exist.

ASR is a chemical reaction between certain types of aggregate and the highly alkaline hydrated Portland Cement. It has the potential of causing significant structural distress, as shown in Figure 1, but in many cases, the cracking can be relatively benign, which appears to be the case at Equestrian Trails Tank, where the cracking has been relatively stable. In rare cases, the deterioration can accelerate; the cracks allow more water to penetrate, producing more expansive gel, causing more cracks. This is a particular concern for water-bearing facilities, where the concrete walls, floors, roofs and columns are continuously saturated.



Figure 1: Example of Advanced Alkali-Silica Reaction. This picture is NOT from a LVMWD Facility.

The dark staining of the cracks is from the gel produced by the internal chemical reaction at the surface of the aggregates.

Although the concrete shown in Figure 1 is badly damaged by ASR, structures that look like this can sometimes remain serviceable for many decades, depending on loading conditions. The cracking at Equestrian (Figure 2) is much less severe.

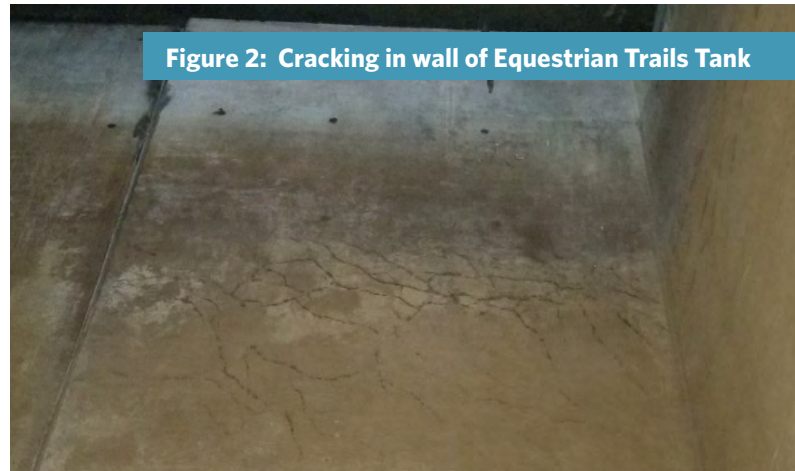

Figure 2: Cracking in wall of Equestrian Trails Tank

Cracking in the walls of Equestrian Trails Tank is more prevalent near the top of the walls, since there is less vertical compression.

Most cracking in the walls, is horizontal, because the concrete can expand upward more readily than outward. Outward expansion is confined by adjacent concrete.

Above, in the corner, there is less confinement and therefore greater horizontal expansion, producing a more-random pattern (e.g., “map cracking”), although the cracks are still more horizontal than vertical.

Over the last several years, the deterioration at Equestrian Tank has been periodically monitored to see whether the extent of cracking would increase or whether significant distress to the structure would appear. Neither of these events has happened, which means that the cost of repairs should be relatively modest, particularly compared to the cost of facility replacement, which would be in the range of \$20 million.

Cracking Concerns

Reinforcing steel is used because concrete is weak in tension and is presumed to crack. The reinforcing steel usually limits the amount of cracking and carries tension forces across the crack opening. In most cases, concrete cracking does not raise structural integrity concerns. The exceptions are:

- 1. Loss of shear capacity.** Significant cracking inhibits the ability to carry shear forces.
- 2. Water leakage.** Cracking can result in leakage from tanks.
- 3. Corrosion of rebar.** Cracking diminishes corrosion protection for the reinforcing steel.
- 4. Structural distress.** Cracks sometimes indicate areas where loading has exceeded structural capacity.

Of these concerns, corrosion of the reinforcing steel is the primary concern at Equestrian Trails Tank. Vertical cracks in the columns and pilasters are common (Figure 3), and these could eventually lead to corrosion of reinforcement. If repairs are not made, damage to the columns could eventually jeopardize the structure.

Apart from the columns, the pilasters, and their footings, the cracking throughout the rest of the tank is not overly concerning. Only minor cracking is seen in the walls, and most of these cracks are close to (or above) the high-water level of the tank. Leakage from the tank should thus be minimal, and little has been detected.

Signs of significant structural distress have also not been observed, nor has significant loss of shear capacity in any member.

Column and Pilaster Cracking

Despite the long-term vertical cracking in the columns, there is no evidence (no spalling or rust strains) to date that would indicate significant rebar corrosion. The cracks have remained filled with calcium carbonate, which has limited the corrosion of the embedded steel. But these cracks will eventually lead to premature rebar corrosion, for reasons explained below.

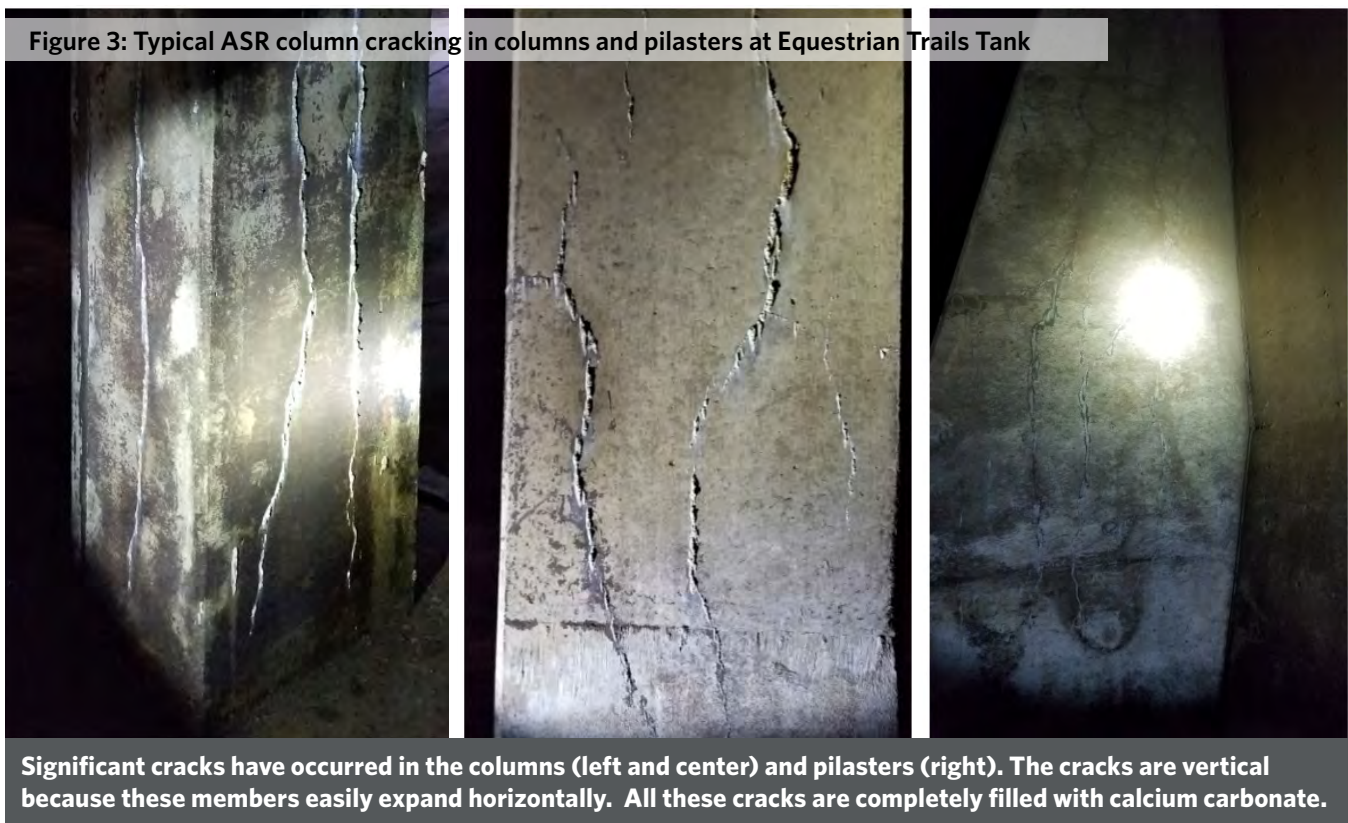

Cracking in the Column Footings

Equestrian Trails Tank has 6 columns and 2 pilasters which support a girder in the center of the tank. The columns have separate footings while the pilaster footings are integral with the wall footings. Because the floor slopes toward the center of the tank, two of the column footings are below the floor, two are on top of the floor, and two are surrounded by the floor. Several of these footings are badly cracked, in areas where no reinforcement is present.

Cracking is widespread in the footings that are above the floor (Figure 4 as seen on the following page), and unlike cracks in the columns some of these cracks are not filled with calcium carbonate. One of these cracks is particularly concerning because an offset has occurred, indicating that the footing is no longer monolithic and does not distribute loads as originally intended. Fortunately, this has not created apparent distress to the floor slab below or to the girder above, but may have contributed to differential settlement of the columns.

Figure 4: ASR footing cracks in Equestrian Trails Tank



Horizontal cracking (top, left) appears in the sides of footings, reflecting an upward expansion

In the tops of the footings (above), the cracking pattern reflects outward expansion.

These cracks are wider and not always filled with calcium carbonate. This is due to the lack of reinforcement near the top of the footing.

An offset in one crack (left) indicates a transfer of stress. This footing is no longer distributing loads as intended.

For the two footings that are partially above and below the slab (Figure 5 below), only minor cracking has been seen. These footings are more confined, so the concrete is less able to expand.

Figure 5: Typical partially embedded column footing at Equestrian Trails Tank

The footings that are partially embedded in the floor slab appear to be in good condition, with few cracks.



The condition of the footings that are below the slab could not be discerned. Because those footings are relatively unconfined, they could have significant cracking. However, these footings are not continuously exposed to fresh water, so any cracks are likely filled with calcium carbonate, and rebar is less likely to corrode.

No evidence of distress to the structure caused by damage to any of the footings has been noted, although some differential settlement may have occurred, as discussed later. As of December, 2017, the floor slab surrounding the columns was not cracked and the joints between the columns and slab were still well caulked. The girder supported by the footings did not exhibit spalling, stress cracking, or other signs of distress, but should be re-examined.

Concerns Regarding Future Corrosion

The high pH chemistry within the concrete that produces ASR also protects reinforcing steel. In the absence of chloride ions, concrete provides excellent protection of embedded steel. Unfortunately, this high-pH environment does not last forever. Degradation occurs naturally as dissolved carbon dioxide reacts with free lime ($\text{Ca}(\text{OH})_2$) producing calcium carbonate. The calcium carbonate often precipitates, plugging the pores and cracks within the concrete—as seen in Figure 3. Precipitation of calcium carbonate slows the degradation. If the water is under-saturated with calcium carbonate, however, some of the calcium carbonate will remain dissolved and leach out of the concrete. How aggressive water is to concrete and other cementitious materials is typically determined by the Langelier Saturation Index (LSI). Because the District's water has a positive LSI, it is considered relatively non-corrosive, which slows the corrosion process, but does not prevent it.

As this “carbonation” process proceeds, the pH of the concrete is neutralized, and much of the corrosion protection it provides to the embedded steel is lost. Carbonation usually occurs slowly, with the boundary between high pH and neutral pH receding into the concrete by only millimeters every few decades. Moreover, the degradation process also slows down, with overlying degraded concrete inhibiting the leaching of calcium from the core.

As shown in Figure 3, calcium carbonate has not just filled the cracks of the columns but it has formed a protruding deposit. The fact that the cracks are tightly filled with calcium carbonate is good news. This inhibits the transmission of water through the crack. By the time water reaches embedded steel, it has an elevated pH and is relatively non-corrosive. Moreover, oxygen transfer is limited, which limits how rapidly corrosion might occur.

However, the protrusion of the calcium carbonate is evidence that calcium is indeed leaching from the concrete, and the pH within the cracked areas is therefore decreasing. If the concrete were uncracked, carbonation could only proceed from the outer surfaces inward. Where concrete is cracked, carbonation can also proceed (although still slowly) from the surfaces within the cracks. Thus, carbonation of cracked concrete eventually leads to premature corrosion of steel.

How rapidly carbonation reaches the embedded steel is not known and is difficult to estimate. To more accurately estimate the remaining service life, samples of the concrete would need to be extracted for testing. It is safe to say that significant corrosion is not yet occurring. When significant corrosion occurs, the corrosion product (rust) is itself expansive, creating outward pressure that will crack and spall the concrete and expose the rebar. As of the last inspection (2017), this had not occurred.

As of the last inspection, there were only two locations where rebar corrosion had been observed. One is near the bottom of the eastern pilaster. The other is at the edge of a roof panel. In both cases, the corrosion resulted from a lack of sufficient concrete cover over the reinforcing steel—errors that occurred when the tank was originally constructed. Such incidents are commonly found in most structures like this. These particular cases are not overly concerning and readily repaired.

Other Structural Issues at Equestrian Tank

Upward Camber and Beam Bearings. Equestrian Tank was originally designed to accommodate tennis courts that were never built, but without the expected weight of the additional concrete, the precast concrete “T” beams camber upward. This has created the water ponding over the center girder shown in Figure 6. This condition has existed since the day the reservoir was constructed and is not a structural concern. The good news is that the rubber water-stops in the joints remain effective in keeping rainwater from penetrating into the reservoir.



Figure 6: Water ponding over center girder, due to upward camber of roof beams

This upward beam camber historically caused Teflon bearing pads at the beam seats to slowly dislodge. These bearings were subsequently replaced in the early 1990s. Inspection of these beam supports, several years later, found a different concern; the walls surrounding the reservoir had moved, very slightly and were bearing on the ends of the beams. Remediation of this latter issue, led to discovery of the ASR cracking in 2004.

Differential Settlement of Columns. Figure 6 shows a slightly larger “bird bath” on the west side of the tank, over the top of Column 6, where differential settlement has likely occurred. Differential settlement of 3 inches between columns at Thousand Oaks’ Meadows Reservoir (a virtual twin to Equestrian Tank) resulted in distress to the main girder, and the potential for catastrophic collapse. Here, the settlement looks to be less significant (concerning, rather than not alarming). The degree of settlement and its effect on the structure should be checked out.

Seismic Restraint. The reservoir roof is seismically restrained in the east-west direction using shear-keys that deliver the roof’s lateral loads into the walls (i.e., a shear-wall system). One of these shear keys is badly fractured due to the differential movement of the north retaining wall relative to the roof structure (Figure 7) and needs to be replaced.

In the north-south direction, seismic loads are currently transferred using steel pins that connect the roof beams to the perimeter wall. This is a less direct method of transferring the loads that is less robust, so an upgrade is recommended. As part of the emergency repairs at Meadows Reservoir, shear-keys were included as an upgrade, as shown in Figure 8.

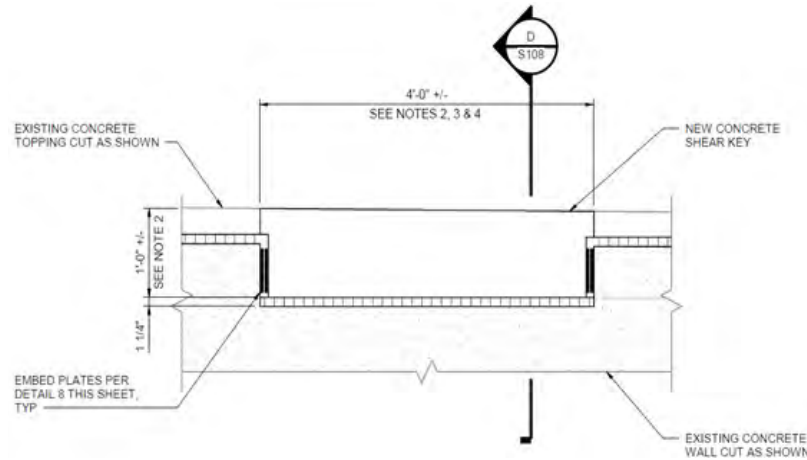

Figure 8: Detail from Meadows Reservoir Emergency Repair, showing the addition of seismic shear key

Other Concerns

Security and safety upgrades are needed at the site, including installation of conduit for future security camera(s), electronic lock, fencing upgrades, and lighting upgrades.

The pavement surrounding the reservoir is likely original to the facility and is badly cracked. While the pavement sees little traffic, it is used to convey rainwater to catch basins. Along the north side of the site, a gap in the asphalt berm is allowing drainage to erode the slope.



Figure 7: Fractured seismic shear key, east side of North Wall at Equestrian (should be replaced)



Figure 9: Hillside erosion caused by failure of pavement

PROJECT APPROACH

HDR's project manager, Dan Ellison, PE, SE, has performed 5 detailed structural assessments of this tank and is well prepared to develop appropriate repair plans, using existing information and input from the District.

However, the last detailed inspection was carried out 8 years ago, so conditions may have changed.

Historically, these inspections were District led and managed and took place over the course of two days. First, the superstructure (beams, girders, and the upper portions of walls and columns) was observed using an inflatable raft. A day or so later, the tank was drained, and conditions were observed from the floor. District-led protocols were observed, so that anything touching the water or the inner surfaces of the tank was disinfected, allowing the tank to be returned to service within a few days.

While dive inspections provide general observations, they are not sufficient to characterize and quantify cracking, corrosion, and other defects needed for sound contract documents. In addition to photographs and notes, HDR would test the concrete in-situ, and take samples for laboratory testing of chloride and hydroxide ion content, which indicates whether the rebar remains well protected.

Removing the tank from service is possible, particularly during periods of low demand, because Morrison Tank and the 5 MG Tank at Las Virgenes Reservoir provide adequate storage for the western part of the backbone system. (Hydraulic modeling performed for several Master Plans has confirmed this.) In any case, the tank will need to be removed from service, for repairs.

Site Survey and Girder Analysis

HDR recommends a licensed surveyor be engaged to prepare a topographic base map, including measurements of the top of slab above each column and pilaster. These measurements will be used to determine the extent that differential settlement has occurred, which would prompt analysis of the main girder. At Thousand Oaks' Meadows Reservoir, differential column settlement caused overstress of the girder and visual observations found the potential for a catastrophic shearing of the girder (Figure 10).

The base map will also allow HDR to show paving and site drainage improvements, and the installation of conduits for future projects.

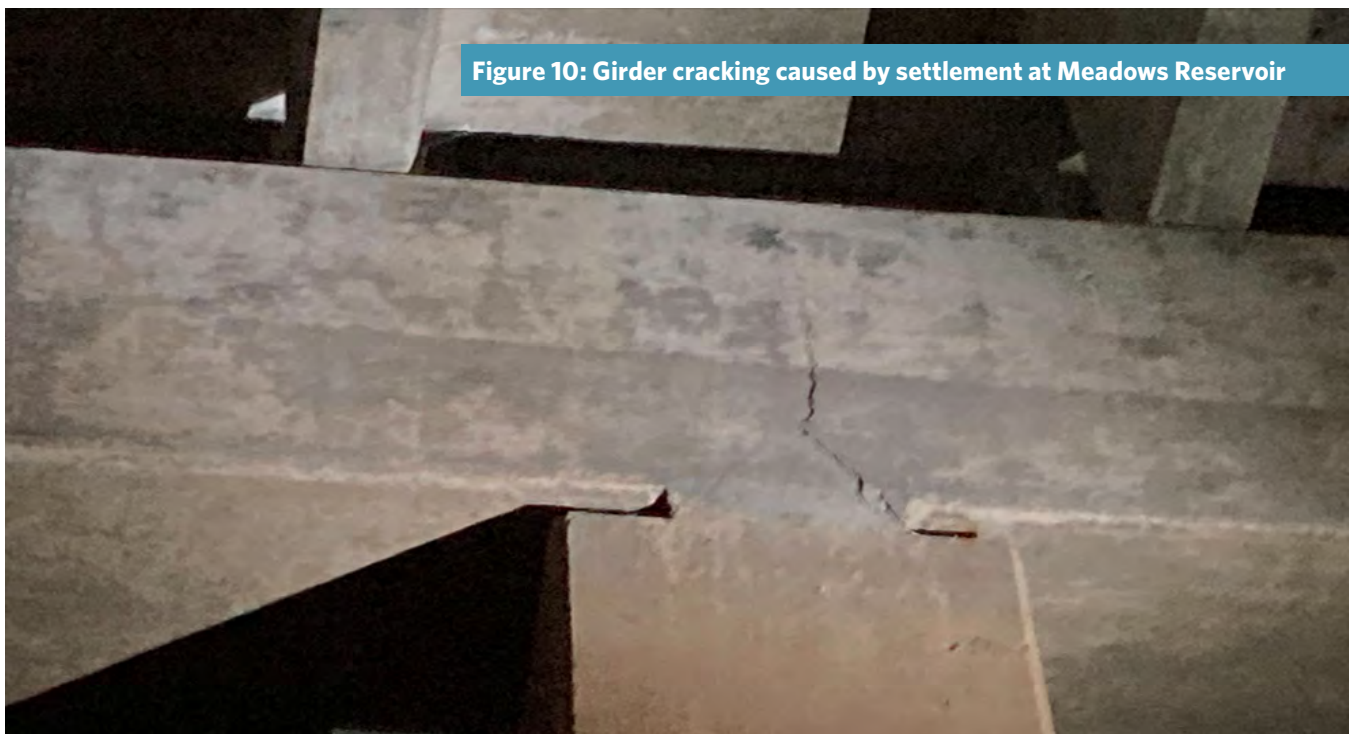

Figure 10: Girder cracking caused by settlement at Meadows Reservoir

Rehabilitation Design

Because the ASR cracking at Equestrian Tank has not yet caused major distress or corrosion, rehabilitation should be relatively modest, extending the life of the tank by decades. Various options can be applied, as listed below.

Rehabilitation Options	
Basic Repairs	Remove / replace loose concrete and spalls; repair with mortar Remove corrosion, coat exposed rebar (if any), and patch with mortar Inject epoxy in footing cracks
Level 1	Continue to monitor cracking every 5 years. Remediate when necessary
Level 2	Apply a spray-applied polyurethane coating as a corrosion barrier
Level 3	Apply a glass-fiber reinforced polymer (GFRP) as a reinforced corrosion barrier
Level 4	Apply a carbon-fiber reinforced polymer (CFRP) wraps to confine concrete, limit crack growth, and act as a reinforced corrosion barrier (Figure 11)

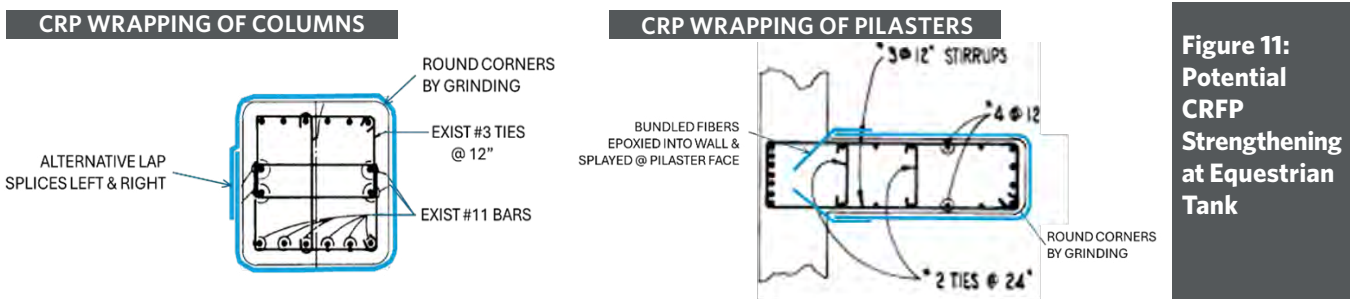

Figure 11:
Potential CRFP Strengthening at Equestrian Tank

Preliminary Recommendations

Table 1 summarizes structural conditions and concerns at Equestrian Trails Tank, and HDR’s preliminary recommendations for mitigating these concerns.

Table 1: Structural Conditions, Concerns, and Preliminary Recommendations – Equestrian Trails Tank		
Structural Condition	Concern	Preliminary Recommendation
Vertical cracks in columns and pilasters	Corrosion of rebar will eventually jeopardize structural integrity of roof support columns and pilasters	Basic repairs + Level 4 rehabilitation (CFRP wrapping of columns & pilasters)
Possible differential settlement of columns	Girder overstress could lead to catastrophic shearing of girder at column face	Survey to determine extent of settlement; analyze girder, as discussed above <ul style="list-style-type: none"> Examine girder for cracking along vertical faces If risk exists, construct bearing wall (or similar), like Meadows Reservoir
Large cracks in column footings	More concentrated pressure distribution at soil interface may lead to additional differential settlement	Perform basic repairs, including: <ul style="list-style-type: none"> Remove/replace loose concrete / fill spalls Inject cracks with epoxy
Longitudinal cracking along top and bottom faces of girder	Corrosion of rebar will eventually jeopardize structural integrity of roof support girder	Basic repairs + Level 3 rehabilitation (GFRP wrapping of girder)
Moderate cracking of floor or walls	Potential minor leakage of water from tank	Basic repairs + Level 2 rehabilitation (spray-applied polyurethane)
Damaged water stops at floor or wall joints	Potential moderate leakage of water from tank	Basic repairs; recaulk joints + Level 2 rehabilitation (spray-applied polyurethane)
Minor (hairline) cracking of walls and floor	No immediate concern	Level 1 – observe cracks every 5 years; take action if cracks become worrisome.

These recommendations may change, depending on results of the proposed internal inspections and discussions with District staff. As part of HDR’s preliminary engineering report, the costs of alternative mitigations will be provided.

Products used inside the tank must be approved for drinking water contact in accordance with NSF61. The use of concrete can be problematic, since project-specific laboratory testing is typically required; such testing takes months to complete.



3 Project Scope



PROJECT SCOPE

This scope of services is based on the District's RFP, including Addendum #1, and the documents referenced in the RFP. HDR will perform the following tasks:

1. PHASE 1. Project Initiation, data review, and site assessment.

1.1. Records Review. HDR will review District-supplied record drawings and reports, including:

- Equestrian Trails Tank Drawings, As-Constructed, 11/10/71.
- Catalyst Diving Inc. Report, dated January 30, 2025
- HDR report, dated January 17, 2018
- 2007 Corrosion Control Program Report, (LVMWD Report 2396.00)
- Preliminary Evaluation of Tank Sites for Earthquake Hazards (LVMWD Report 1661.)

1.2. Virtual Kickoff Meeting. HDR will attend and facilitate a project kickoff meeting, including:

- Prepare and distribute meeting agenda, 2 business days before the meeting
- Prepare and distribute meeting notes, including action items

1.3. Site Inspections and Observations. In conjunction with the Kickoff Meeting, HDR will visit the tank site with LVMWD Operations and Engineering staff. HDR will interview staff, take photos and take notes.

1.3.1. Optional In-Tank Inspections. Upon written authorization by Las Virgenes, HDR will participate in the following:

1.3.1.1. Inspection Planning & Documentation.

Participate and facilitate conference call with LVMWD staff to discuss logistics and coordination for in-tank inspections. HDR will prepare job-hazard analysis and safety plans, as required for its own work.

Provide post-inspection report, including results of laboratory tests, field tests, photos and observations.

1.3.1.2. Float Inspection. HDR will participate in a float inspection with LVMWD staff, to observe the underside of the roof, roof beams, girder, beam seats, and upper portions of walls, columns and pilasters.

1.3.1.3. Dry Inspection. HDR will participate in a dry inspection with LVMWD staff, to observe the lower portions of walls, columns and pilasters, as well as the floor slab. HDR will:

- Observe and document general conditions of girders, beams, columns, floor slab, and exposed footings. Special attention will be paid to two footings that are badly cracked.
- Perform surface penetrating radar scanning to confirm general rebar spacing and depth in sample locations of walls, columns, pilasters, and floor.
- Extract one or two concrete cores from walls for field stain testing and for laboratory testing of pH, chloride ions, and hydroxide ions at various depths. Holes will be filled with rapid-setting, NSF61-certified grout.

Historically, these inspections were led by the District, which was best equipped to coordinate the work with District operations, and assure conformance with safety and disinfectant protocols. The District provided the inflatable raft, personal floatation devices, retrieval tripod, ropes, lighting, and other equipment.

Inspection Options If the float inspection is logistically difficult, with good lighting HDR can accomplish relatively good observations of the roof members during the dry inspection (HDR can provide the lighting).

If the dry inspection is logistically difficult, HDR can provide a submersible remotely operated vehicle (ROV) for inspections above and below the water level. The ROV provides better results than a dive inspection, because it would be operated under the guidance of the Engineer of Record. However, a dry inspection is preferred, as visual images are clearer, samples of concrete can be obtained, sounding of the concrete can be performed, and physical measurements can be obtained.

1.4. Optional Site Survey. Upon written authorization by Las Virgenes, HDR will engage a licensed land surveyor (Encompass Consulting Group) to develop a topographic base map of the site, including the paved areas, fencing, and roof of the tank. Survey will include: top of roof elevations at 12 specific locations:

- Each corner of the roof
- Above each of 6 columns
- Above each of 2 pilasters

The property boundaries will be based on the Assessor's Parcel Map.

1.4.1. Optional Structural Analysis of Main Gider.

Upon written authorization by Las Virgenes, HDR will analyze stresses associated with excessive differential settlement of the columns. (Differential settlement greater than 3/8 inches would warrant this analysis.)

Phase 1 Deliverable. Findings from Phase 1 investigations will be provided as part of the Preliminary Engineering Technical Memorandum (Task 2.1).

1.5. Project Initiation, Management and Control. HDR will set up accounting / file / document control systems, prepare a project management manual, conduct a PARR (Project Approach and Resources Review), perform periodic management reviews and provide monthly status reports with each invoice.

2. PHASE 2. Preliminary Design and Final Design

2.1. Preliminary Engineering Technical Memorandum.

HDR will prepare a technical memorandum describing the findings of its investigations, including the extent of cracking, settlement, corrosion, seismic resistance and associated concerns. HDR will provide alternatives for addressing these concerns, including preliminary opinion of probable costs. This task will include:

- Draft Report
- Review Workshop
- Final Report

2.2. Bid Documents. HDR will prepare 60%, 90%, and 100% plans and specifications (front-end and technical). Final bid plans are to be signed and stamped by a qualified, professional engineer.

- Technical Specifications will be based on HDR standard specifications.
- The District will provide the front-end documents, and special / general provisions which HDR will edit, including a summary of work, a bid schedule, and a measurement and payment specification. Measurement and payment will provide a clear summary of what each bid line item must be used for, and the work entailed per bid line item.
- Review Meeting. Meet to discuss comments on 60% and 90% design submittals. The meetings can be virtual or in person.
- OPCC. HDR will provide its opinion of probable construction cost at each design milestones (60%, 90%, and 100%). The OPCC shall match the format of the Schedule of Bid Items in the Specifications.

- Preliminary Construction Schedule. HDR will provide a preliminary schedule showing how the construction contractor might effectively accomplish the work. This schedule will be used to determine an appropriate construction contract duration.

3. Phase 3. Bid and Construction-Phase Services. HDR will:

3.1. Attend the Pre-Bid Meeting

3.2. Prepare up to 2 bid addenda

3.3. Attend Pre-Construction Meeting

3.4. Review technical documents, including:

- Up to 25 submittals, including resubmittals
- Up to 5 RFIs or change order requests / claims

3.5. Attend up to 5 project meetings (2 on site and 3 virtual)

3.6. Participate in Final Job Walk, including development of a punchlist

3.7. Prepare record drawings based on Contractor's markups

3.8. Optional Site Inspections. If authorized, HDR will prepare a contract amendment request, to provide full-time coating inspection by an experienced, AMPP-certified, Level 3 coating inspector.

Assumptions and Exclusions

1. HDR will perform the tasks described in the Scope of Services on a time-and-materials basis, in accordance with the terms and conditions of a mutually accepted agreement.
2. The maximum fee shown in the Fee Estimate will not be exceeded, unless approved in writing by the District.
3. Work will be completed in general accordance with the schedule below. The project schedule and constraints will be discussed during the Kickoff meeting.
4. The design effort is based on the tank conditions and preliminary recommendations described in the proposal.
5. Repairs will consist of CFRP wrapping of girder, columns, beams, and pilasters, crack injection at the exposed column footings, and the "basic repairs" described in HDR's proposal. CFRP repairs will be designed per American Concrete Institute Standard ACI 440.2R .



6. The following drawings are anticipated:

Dwg	Sheet	Description
1	G-1	Cover Sheet. Vicinity / Location Map. Sheet Index
2	C-1	Site paving and drainage plan
3	C-2	Civil details
4	S-1	Structural General Notes
5	S-2	Structural Inspections / Abbreviations
6	S-3	Floor and Footing Plan
7	S-4	Roof and Framing Plan
8	S-5	Structural Details
9	S-6	Structural Details
10	E-1	Electrical Plan
11	E-2	Lighting Plan
12	E-3	Electrical Details

7. Drawings will be based on the dimensions and details shown in the Record Drawings, unless the optional site survey is authorized by the District, in which case Civil sheets will utilize the base map provided by the Surveyor.

8. If the site survey confirms that significant differential settlement has occurred and the girder analysis determines that significant structural upgrade is required, HDR will prepare an appropriate amendment request for the necessary structural upgrades.

Design Schedule

The HDR Team commits to completing the Equestrian Tank Rehabilitation Project Design as shown below. The schedule outlines our approach and incorporates each task and milestones for our deliverables.

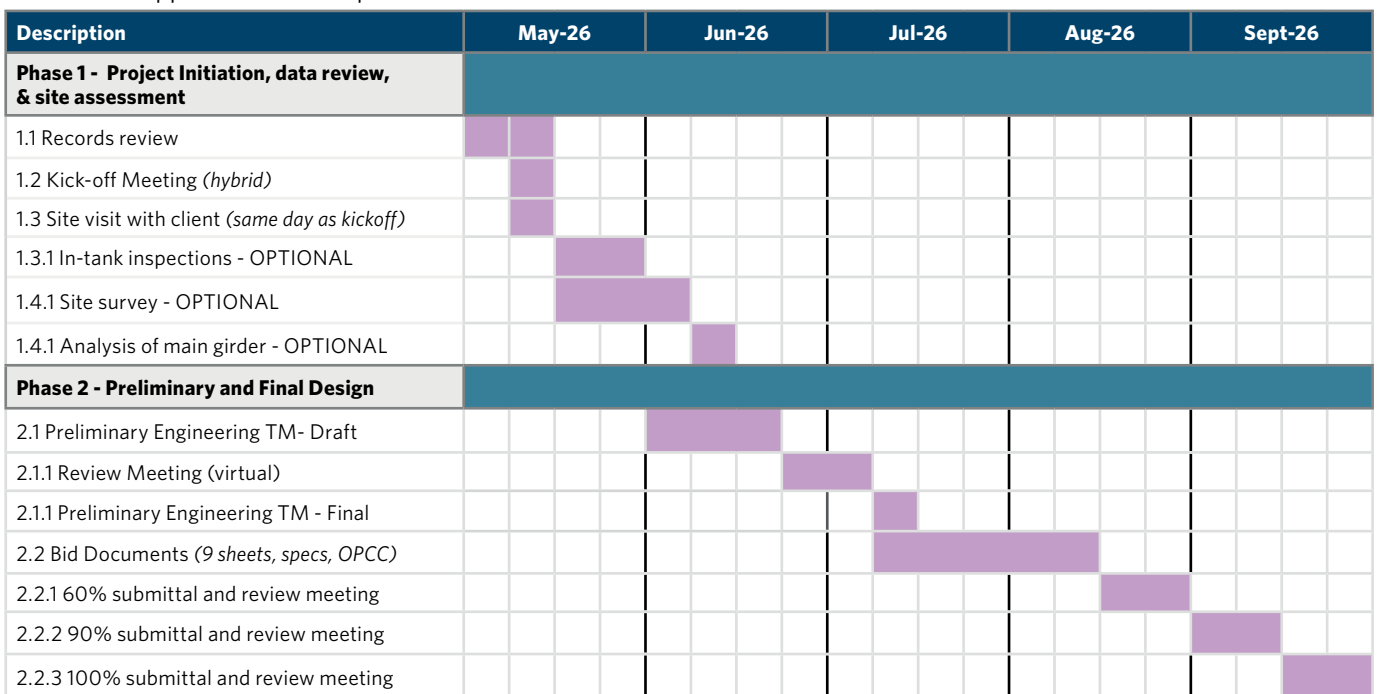

Phases HDR Task Time Frame

9. The optional float and dry inspections will be led by the District, which will provide the inflatable raft, floatation vests, retrieval tripod, ropes, air testing, ventilation, disinfection, lighting, and permit. (This assumption is based on how these inspections were historically conducted. If necessary, HDR can take on some of these responsibilities.)

10. It is understood that condition assessment methods are imperfect, and are not guaranteed to detect hidden, covered, inaccessible, or internal material defects. Periodic re-inspections and evaluations (approximately every 5 years) will be required.

11. Addenda prepared during bidding does not include CAD hours. If required, any modifications to drawings will be done in PDF via Bluebeam Studio markups.

12. The fee for Optional Site Inspection includes \$290 per diem for travel expenses. On-site inspection is assumed to be a maximum of 25 working days (5 weeks), covering the wrapping of columns, pilasters, and girder, and basic repairs to footings.

13. An overall project duration of 12 months has been assumed, including 5 months for preliminary and final design, 2 months for bidding and award, 3 months for submittal preparation and review, and 2 months for



4 Project Team



PROJECT TEAM

ORGANIZATIONAL CHART

The individuals proposed for this project are a team of highly qualified staff, tailored to support the District with this important project. Each member of our inter-disciplinary team has been thoughtfully selected for their expertise, experience, and availability. We are dedicated to achieving your vision and will commit the time and effort needed to perform effectively and efficiently. The organizational chart below provides the name and job title of each proposed team member and supporting profiles for key team members are included.

RESOURCE CAPACITY Our HDR team is dedicated to the District and confirm that all key personnel will be both available and involved to the extent proposed for the duration of the project. We have a local Ventura Office that will provide our base of operations to support this project.

Team Resource Capacity			
Principal-in-Charge John Coffman, PE, CCM	Up to 4 hrs/wk	Site Improvements James Kelly, PE	40 hrs total
Project Manager Dan Ellison, PE, SE	Up to 20 hrs/wk	Structural Engineer Ryan Wright, PE	32 hrs total
Structural QC/Technical Advisor Tom Hamlin, PE, SE, NCEES	16 hrs total	Structural Engineer Vince Morello, PE	Up to 20 hrs/wk
CFRP QC/Technical Advisor Ron Manske, PE, SE	16 hrs total	Optional In-Tank Inspections Sean Hoss, PE, AMPP-1, PACP	As-needed
Project Engineer Jon Paz, EIT	Up to 20 hrs/wk	Optional Site Survey James Fallon, LS	As-needed
Electrical, I&C, Security Justin Lee, PE	43 hrs total		

Our team’s bios and project history is shown in the following pages and again in the resumes found in the Appendix.

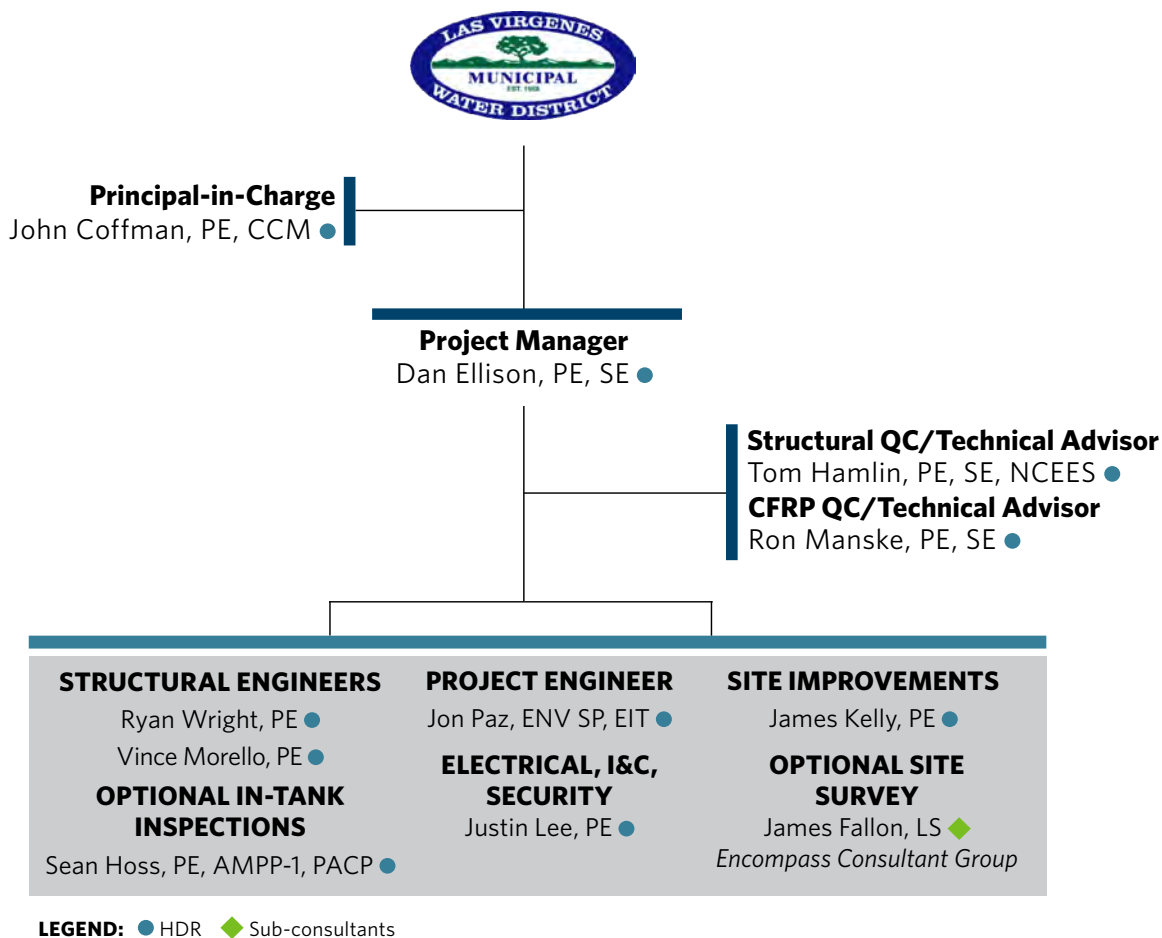

PROJECT TEAM

JOHN COFFMAN, PE, CCM | HDR | PRINCIPAL-IN-CHARGE



John is a professional engineer and certified construction manager with 30 years of civil engineering, project management, estimating, and construction management experience for municipal clients. He has led design and construction management for potable and wastewater pipelines, reservoirs, pump stations, and treatment-plant site civil work. He is well-versed in permit coordination, bid documents, and construction-phase engineering, and his construction background helps him produce clear, highly constructible plans.

EDUCATION BS | Civil Engineering | California Polytechnic State University, San Luis Obispo | 1995

REGISTRATIONS Professional Engineer: CA No. C60754 | Certified Construction Manager (CCM): CA No. 7219

INDUSTRY EXPERIENCE 30 years | **YEARS WITH HDR** 6 years

RELEVANT EXPERIENCE

- ✓ Las Virgenes Municipal Water District: Westlake Filtration Plant Expansion
- ✓ Las Virgenes Municipal Water District: Westlake Pump Station
- ✓ Las Virgenes Municipal Water District: 5MG Reservoir/36in Steel Pipeline
- ✓ California Water Services: Harris Reservoir Replacement

DAN ELLISON, PE, SE | HDR | PROJECT MANAGER



Dan is a recognized authority on condition assessment, rehabilitation, and trenchless construction, having authored eight books on these subjects. He has managed the evaluation and design of more than six dozen tanks and reservoirs. Dan's unique qualifications for this project:

- ✓ Five previous evaluations of Equestrian Tank
- ✓ In-depth knowledge of Backbone System hydraulics from 3 Master Plan projects
- ✓ Emergency Repairs of Meadows Reservoir

EDUCATION MBA | Finance | University of Southern California | 1994; BS | Civil Engineering | University of Utah | 1981; BA | English | University of Utah | 1978

REGISTRATIONS Professional Engineer: CA No. C38094 | Structural Engineer: CA No. S3020

INDUSTRY EXPERIENCE 44 years | **YEARS WITH HDR** 14 years

RELEVANT EXPERIENCE

- ✓ Las Virgenes Municipal Water District: Equestrian Tank Evaluations
- ✓ Las Virgenes Municipal Water District: Calabasas (8 MG) Tank Rehab
- ✓ City of Thousand Oaks: Meadows Reservoir Emergency Repairs
- ✓ City of Ventura: Bailey Reservoirs 1 and 2 Evaluation
- ✓ City of Thousand Oaks: HCTP Digesters No. 1, 2, and 3 Rehabilitation

TOM HAMLIN, PE, SE, NCEES | HDR | STRUCTURAL QC/TECHNICAL ADVISOR



Tom has 22 years of structural engineering experience spanning assessments, investigations, design, QC, and construction administration for water/wastewater, industrial, mining, data center, and federal facilities. He specializes in evaluating, repairing, and upgrading existing buildings—including seismic work per ASCE 41. His clients include the U.S. Army Corps of Engineers, NAVFAC, LOTT Clean Water Alliance, San Diego Public Utilities, Las Vegas Valley Water District, and the cities of Phoenix, Tucson, Scottsdale, Las Vegas, Billings, Anacortes, and Kennewick.

EDUCATION MS | Civil and Environmental Engineering | South Dakota State University | 2004; BS | Civil and Environmental Engineering | South Dakota State University | 2003

REGISTRATIONS Professional Engineer: CA No. 71864 | Professional Engineer: MT No. PEL-PE-LIC-27040 | Structural Engineer: CA No. S6122 | Structural Engineer: AZ No. 54311 | Structural Engineer: NM No. 23315 | Structural Engineer: HI No. PE-16088 | Structural Engineer: UT No. 10670513-2203 | NCEES No. 56771

INDUSTRY EXPERIENCE 22 years | **YEARS WITH HDR** 21 years

RELEVANT EXPERIENCE

- ✓ City of Thousand Oaks: Meadows Reservoir Emergency Repairs
- ✓ City of Ventura: VenturaWaterPure Ocean Outfall Pump Station
- ✓ Tuscon Water, Reservoir and Tank Rehabilitation Program

RON MANSKE, PE, SE | HDR | CFRP QC/TECHNICAL ADVISOR



Ron is HDR's global director of structural engineering with 28 years of experience. He specializes in designing, constructing, and assessing water and wastewater facilities, including complex concrete structures, vibration-sensitive systems, corrosive environments, and adaptive reuse. His portfolio includes potable water treatment, pipelines, pump stations, and wastewater facilities. Known for strong collaboration and integrating design with construction, Ron delivers efficient, sustainable, and resilient engineering solutions.

EDUCATION MS | Structural Engineering | Colorado State University | 2004; BS | Civil Engineering | University of Wisconsin | Platteville | 1997

REGISTRATIONS Professional Engineer: CA No. 64964 | Professional Engineer: WY No. 13922 | Professional Engineer: TX No. 93353 | Professional Engineer: CO No. 38655 | Structural Engineer: CA No. 6154 | Professional Structural Engineer: AZ No. 71523 | Professional Structural Engineer: ID No. 21207 | Professional Structural Engineer: AL No. 53654

INDUSTRY EXPERIENCE 28 years | **YEARS WITH HDR** 13 years

RELEVANT EXPERIENCE

- ✓ City of Westminster: Northridge Tanks
- ✓ City of Thousand Oaks: Meadows Reservoir Emergency Repairs
- ✓ City of Boulder: Betasso Water Treatment Plant Assessment, Design, and Construction
- ✓ City of Arvada: Storage Tank

JON PAZ, ENV SP, EIT | HDR | PROJECT ENGINEER



Jon develops water and wastewater infrastructure solutions that meet current needs while supporting long-term system resilience. He brings a proactive, organized, and communicative approach, backed by a strong record of delivering engineering designs that align with client goals. His work spans detailed design development, technical reports and alternatives analyses, cost estimating, and construction-phase support through submittal and RFI review. He also manages projects, budgets, resources, proposals, and client coordination, ensuring smooth execution from planning through delivery.

EDUCATION MS | Engineering and Technology Management | Colorado School Mines | 2018; BS | Environmental Engineering | Colorado School of Mines | 2017

REGISTRATIONS Envision Sustainability Professional: CA No. 32631 | Engineer-in-Training: CO No. 73511

INDUSTRY EXPERIENCE 7 years | **YEARS WITH HDR** 7 years

RELEVANT EXPERIENCE

- ✓ City of Thousand Oaks: Meadows Reservoir Emergency Repairs
- ✓ City of Thousand Oaks: HCTP Digesters No. 1, 2, and 3 Rehabilitation
- ✓ City of Thousand Oaks: Wilder Reservoir Improvements
- ✓ City of Ventura: Bailey Reservoirs 1 and 2 Evaluations
- ✓ Long Beach Utilities Department: Tank Assessment and Master Plan

JAMES KELLY, PE | HDR | SITE IMPROVEMENTS



James is a professional engineer with 11 years of experience in civil land development and civil site engineering design in Los Angeles and Ventura Counties. He's skilled in client communication and has managed projects for both public and private clients. His background in water, wastewater, and storm drain design gives him a strong understanding of underground infrastructure and how to maintain critical paths. He has designed pipelines, tanks, wells, and pump stations across Ventura County and is familiar with major water pipe materials, including CMLC steel and HDPE.

EDUCATION BS | Civil Engineering | California Polytechnic State University, San Luis Obispo | 2014

REGISTRATIONS Professional Engineer: CA No. 88317

INDUSTRY EXPERIENCE 11 years | **YEARS WITH HDR** 2 years

RELEVANT EXPERIENCE

- ✓ City of Ventura, VenturaWaterPure Ocean Outfall Pipeline
- ✓ United Water Conservation District: Freeman Conveyance System Upgrade
- ✓ City of Camarillo, Pleasant Valley Force Main and Pump Station
- ✓ Metropolitan Water District, Sepulveda Feeder PCCP Rehabilitation - Reach 9/Chatsworth
- ✓ City of San Diego, Jamacha Drainage Channel Upgrade

RYAN WRIGHT, PE | HDR | STRUCTURAL ENGINEER



Ryan is a professional engineer with structural design and analysis experience, including preparing and reviewing calculations, conducting investigations, and developing details, reports, and specifications. His work in water and wastewater treatment, industrial facilities, and mining projects has built his expertise in reservoir inspection, rehabilitation design, and building systems. He independently manages small to mid-scale assignments and supports complex, multi-engineer projects.

EDUCATION MS | Civil Engineering | Morgan State University | 2013; BS | Civil Engineering | Morgan State University | 2011

REGISTRATIONS Professional Engineer: CA No. 98818 | Professional Engineer: AZ No. 62528 | Professional Engineer: NV No. 030882 | Professional Engineer: ID No. P-22477

INDUSTRY EXPERIENCE 20 years | **YEARS WITH HDR** 12 years

RELEVANT EXPERIENCE

- ✓ City of Thousand Oaks: Meadows Reservoir Emergency Repairs
- ✓ Orange County Sanitation District: Dewatering and Odor Control at Plant No. 1 (P1-101)
- ✓ City of Ventura: Ocean Outfall Pump Station
- ✓ City of San Mateo: Nutrient Removal and Wet Weather Flow Mgmt. Upgrade and Expansion

VINCE MORELLO, PE | HDR | STRUCTURAL ENGINEER



Vince offers 7 years of experience in structural engineering. His experience includes the structural design and construction phase support of reservoir rehabilitations, steel tank rehabilitations, water treatment plants, lift stations, and vaults. He also has experience in performing field inspections of concrete water reservoirs and steel tanks.

EDUCATION MS | Structural Engineering, University of Alabama at Birmingham | 2022; BS | Civil Engineering | University of Arizona | 2018

REGISTRATIONS Professional Engineer: AZ No. 78535

INDUSTRY EXPERIENCE 7 years | **YEARS WITH HDR** 6 years

RELEVANT EXPERIENCE

- ✓ City of Thousand Oaks: Meadows Reservoir Emergency Repairs
- ✓ City of Thousand Oaks: Wilder Reservoir Impvs.
- ✓ Tucson Water: Reservoir Amendment 17
- ✓ Clark County Water Reclamation District: FWRC Preliminary and Primary Treatment Impvs.
- ✓ Tucson Water: Escalante Reservoir

SEAN HOSS, PE, AMPP CIP1, PACP | HDR | OPTIONAL IN-TANK INSPECTIONS



Sean is a project manager focused on design and inspection for water and wastewater projects across California. He has extensive experience in concrete and pipeline condition assessment for concrete tanks and basins, dams, storm drains, and sewers, including six years of rope-access inspections on spillways and treatment structures. His work spans treatment facility design and inspection, municipal system inspections, construction administration, environmental site investigations, State Revolving Fund preparation, cost estimating, data and database management, and quality assurance on construction projects.

EDUCATION BS | Civil Engineering | California State Polytechnic University, Pomona | 2008

REGISTRATIONS Professional Engineer: CA No. 79964 | AMPP Coating Inspector Level 1 No. 103296 | NASSCO PACP, MACP, and LACP No. P0033418-082021

INDUSTRY EXPERIENCE 17 years | **YEARS WITH HDR** 17 years

RELEVANT EXPERIENCE

- ✓ Irvine Ranch Water District: Michelson WRP Backwash Tank Condition Assessment (CA)
- ✓ Orange County Sanitation District: College Pump Station Wet Well CA Study
- ✓ Eastern Municipal Water District: Temecula Valley Regional WRF Biofilter Concrete CA
- ✓ Metropolitan Water District: Lake Matthews Forebay Headworks Valve Structure CA
- ✓ Eastern Municipal Water District: Moreno Valley Regional WRF Acid Phase Digester

JUSTIN LEE, PE | HDR | ELECTRICAL, I&C, SECURITY



Justin has more than 10 years of experience designing electrical and instrumentation plan drawings and specifications for water and wastewater treatment facility projects. This includes power plans, one-line diagrams, elevations, details, panel schedules, control diagrams, and process and instrumentation diagrams. He has provided engineering services during construction for several projects that includes reviewing submittals, responding to RFIs, and preparing revised drawings.

EDUCATION BS | Electrical Engineering | California State University, Fullerton | 2017

REGISTRATIONS Professional Engineer: CA No. 24124

INDUSTRY EXPERIENCE 10 years | **YEARS WITH HDR** 8 years

RELEVANT EXPERIENCE

- ✓ City of Thousand Oaks: HCTP Tertiary Filters Rehabilitation
- ✓ City of Thousand Oaks: Wilder Reservoir Improvements
- ✓ Irvine Ranch Water District: Michelson WRP Tertiary Filters Improvements
- ✓ Long Beach Utilities Department: Alamitos Tank Nos. 19 and 20 Conversion Project
- ✓ City of Ventura: Aeration Blower Replacement
- ✓ Santa Margarita Water District: Oso Creek WRP Design and Construction Services
- ✓ City of North Platte and Sustainable Beef: North Platte Industrial WWTP

JAMES FALLON, LS | ENCOMPASS CIVIL GROUP | OPTIONAL SITE SURVEY



James has 24 years of experience in land surveying and geomatics, managing field and office survey work for public infrastructure and private development. His expertise includes topographic mapping, boundary and ALTA surveys, legal descriptions, subdivision mapping, construction staking, and GIS data collection, with extensive corridor survey experience across Southern California. He is skilled with static and RTK GPS, CORS-based control networks, and proficient in AutoCAD Civil 3D, Microsoft Office, Trimble GPS software, ArcGIS, and major surveying and adjustment tools.

EDUCATION BS | Surveying Engineering | California State University, Fresno | 1999

REGISTRATIONS Professional Land Surveyor: CA No. 7807

INDUSTRY EXPERIENCE 24 years | **YEARS WITH ENCOMPASS** 10 years

RELEVANT EXPERIENCE

- ✓ City of Ventura - Ventura Ocean Outfall and Pump Station
- ✓ City of Ventura - Ventura Aeration Blower Wastewater Treatment Plant
- ✓ City of Camarillo - Pleasant Valley Force Main
- ✓ Las Virgenes Municipal Water District - Malibu Lake Sewer Siphon
- ✓ City of Thousand Oaks - Meadows Reservoir, Emergency Repairs



Our Team has a long history of working together with Las Virgenes to develop innovative solutions to various challenges.



5 Quality Control Process



QUALITY CONTROL PROCESS

HDR aims to consistently provide professional services as trusted experts and problem solvers that satisfy statutory, regulatory and contractual requirements. HDR’s culture recognizes that quality products actually cost less to produce by avoiding errors. Quality products also create “customers for life.” A particular HDR strategy is using our industry-leading experts, to get projects started in the right direction.

To achieve our goals, HDR has developed a Quality Management System (QMS) based on the principles and

guidelines set forth by the ISO 9001:2015 international standard for quality management.

The QMS includes programs, policies, and business processes that adhere to client and local, state, and federal guidelines. We perform quality reviews throughout the project to facilitate communication. Our QMS utilizes the data, reports, and figures captured through project controls and our project management plan. We believe managing the quality of deliverables is essential to minimizing cost and maintaining schedule.

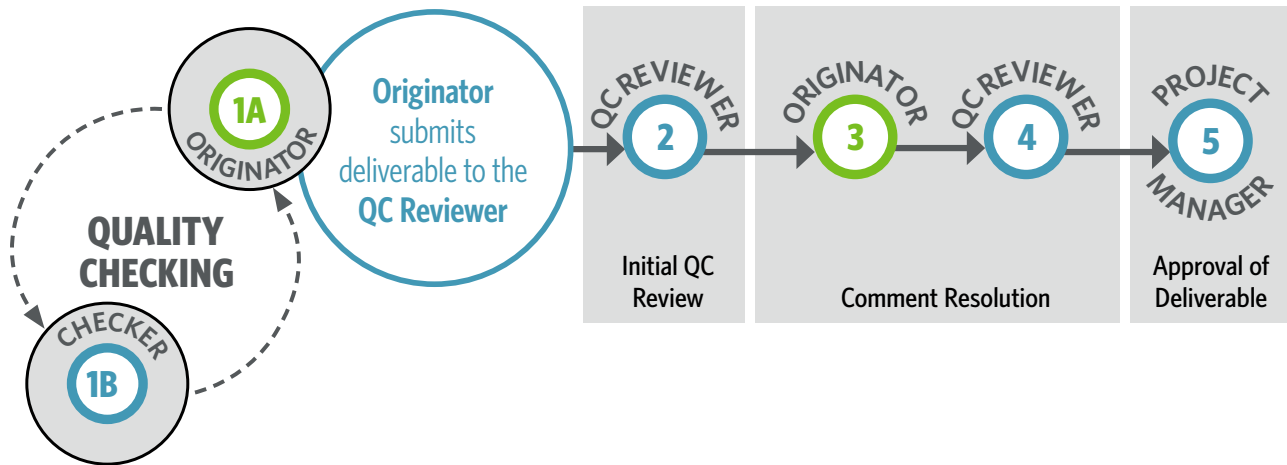

While checking for errors before deliverables go out the door is always important, preventing the errors is more important. In this regard, HDR has processes that track the development of the project, starting on Day One:

- The **Project Approach and Resource Review (PARR)** is a rigorous review conducted early in the project, with subject-matter experts who verify that the right approach and best resources are being applied to optimally solve issues.
- The **Zero-Percent Management Review** is likewise conducted at the beginning, to assure that deliverables will meet contract requirements, including schedule and on budget targets. Several periodic management reviews follow, depending on the size and complexity of the project.



6 Sub-consultant Qualifications



SUB-CONSULTANT QUALIFICATIONS



Encompass Consultant Group (ECG) is a local, employee-owned firm established in 2016, deeply invested in the long-term success

of the communities we serve. Our team of engineers, surveyors, and technical specialists brings decades of experience in delivering innovative and cost-effective solutions for public infrastructure projects. Our team has worked together for over 20 years—some for more than 25—successfully delivering municipal and capital improvement projects throughout Los Angeles, Ventura, and Santa Barbara Counties. This extensive experience gives us a deep understanding of local agency standards, regulations, permitting processes, and community priorities, ensuring seamless project execution.

ECG has assembled a team of professionals with the technical experience and public agency experience necessary to meet the diverse needs of public on-call contracts.

- ✓ Registered Licensed Land Surveyors
- ✓ Latest Surveying Technologies
- ✓ Highly Skilled Data Processors
- ✓ Multiple Field Crews

Our team includes licensed surveyors and skilled professionals, each with significant experience in public works and roadway improvements. Our selected team

has a long history of experience in similar projects across Ventura, Santa Barbara, and Los Angeles Counties, with a thorough understanding of local survey requirements and public agency procedures. This local knowledge ensures that we are exceptionally well-equipped to handle the project requirements with the precision and efficiency that on-call contracts demand.

The ECG Survey team is an experienced combination of both field and office professionals, ensuring we offer a complete solution from start to finish. With extensive training in the latest technologies, including advanced GPS, LiDAR, and Aerial Imagery, this proficiency in cutting-edge tools allows us to deliver highly accurate data while enhancing efficiency in the field. Our team is equally adept in both fieldwork and technical data processing, ensuring that we not only capture precise measurements but also meticulously analyze and interpret the data to produce reliable results. By integrating these modern technologies with our field expertise, we can streamline workflows, reduce errors, and provide our clients with comprehensive, high-quality survey results while maintaining consistent availability and responsiveness with multiple field crews ready for mobilization.

Several of the ECG Survey Staff, including James Fallon, live locally and have provided support to HDR on various nearby and neighboring City and County projects.

Project Examples / Client Contacts

VENTURAWATERPURE OCEAN OUTFALL PIPELINE I City of Ventura,		MEADOWS RESERVOIR EMERGENCY REPAIRS I City of Thousand Oaks	
ECG was contracted by HDR to provide survey services for the 3.5-mile, 20-inch ocean outfall pipeline that diverts wet-weather flows and reverse osmosis concentrate offshore. The project required extensive permitting, hydraulic modeling, survey, and detailed construction sequencing to maintain the schedule for the December 2025 consent-decree deadline		ECG performed several surveys, needed to determine the extend of differential settlement and whether the settlement was continuing. ECG responded promptly, allowing repairs to be completed before “fire season”.	
CLIENT	HDR	CLIENT	HDR
CONTACT/TITLE	Alex Roberts, Principle Engineer	CONTACT/TITLE	Dan Ellison, PE, SE, Project Manager
PHONE	(805) 275-8289	PHONE	(213) 200-5152
EMAIL	aroberts@cityofventura.ca.gov	EMAIL	Dan.Ellison@hdrinc.com
AERATION SYSTEM IMPROVEMENTS I City of Ventura			
ECG provided a site survey for construction of a new building to house aeration blowers for Ventura's Water Recycling Facility. These services included obtaining critical X, Y, Z, locations for air piping connections, 15 feet above grade. These measurements allowed a 24-inch header pipe to pass below an existing stair way, with less than 2 inches of clearance.			
CLIENT	HDR		
CONTACT/TITLE	Dan Ellison, PE, SE, Project Manager		
PHONE	(213) 200-5152		
EMAIL	Dan.Ellison@hdrinc.com		



7 Project Examples



Meadows Reservoir Emergency Repairs

City of Thousand Oaks | Thousand Oaks, California

Client Contact:

City of Thousand Oaks
Nader Haidari
Public Works Director,
Ph: 805.449.2392
Nheydari@toaks.org

Project Staff:

Project Manager
Dan Ellison, PE, SE
Project Management Assistance / Project Engineer
Jon Paz, EIT
Structural QC
Tom Hamlin, PE, SE
Technical Advisor
Ron Manske, SE
Survey
James Fallon, LS (ECG)

Similar Scope Items:

- Structural repairs of rectangular concrete tank
- Tank design is virtual twin of Equestrian Tank
- Differential settlement may be a concern at Equestrian like Meadows
- Sole-source (emergency) selection by City, in recognition of HDR's special knowledge and rehabilitation expertise



HDR was retained by the City of Thousand Oaks to investigate major distress at a 3.3MG water reservoir. The reservoir, a rectangular reinforced concrete tank originally constructed in 1973, experienced significant leakage in 2021 at 40 gallons per minute. The City engaged the HDR team to perform an assessment, as our team was familiar with both the facility and the City's system.

The reservoir was quickly removed from service and emptied so that the HDR team could determine the cause of the leakage. Upon initial investigation, the facility appeared to be in remarkably good condition; however, once the remaining water at the bottom of the reservoir finally drained, our team discovered that an embedded waterstop against a floor slab had torn apart, thus revealing the source of the significant flow.

HDR engaged Encompass Consulting Group, Inc. (ECG) to perform an elevation survey. The survey determined that two of the six columns had undergone an unusual amount of settlement, creating severe distress and the potential of roof collapse. HDR recommended that a portion of the roof be removed to alleviate loading and prevent further damage.

HDR then designed an innovative system to restore long-term structural integrity and return the reservoir to service quickly. Working with Fugro, Spiess Construction, T&T Crane, and City staff, a fast-track design was developed, which included the use of two large cranes to temporarily remove a portion of the roof, relieving loads from the distressed main girder and facilitating construction of a bearing wall. A key concern was how to place the cranes, such that the existing retaining walls would not be overstressed.

Equestrian Trails Tank Evaluations

Las Virgenes Municipal Water District | Calabasas, California

Client Reference:

Las Virgenes Municipal
Water District
John Zhao
Former Director of Facilities &
Operations
P: (805) 679-3713
Jzhao@lvmwd.com

Project Staff:

Project Manager
Dan Ellison, PE, SE

Similar Scope Items:

- Unmatched familiarity with history and concerns at Equestrian Tank
- Deep understanding of cracks at Equestrian and the related concerns
- Knowledge of crack progression since 2004, thru 5 separate evaluations

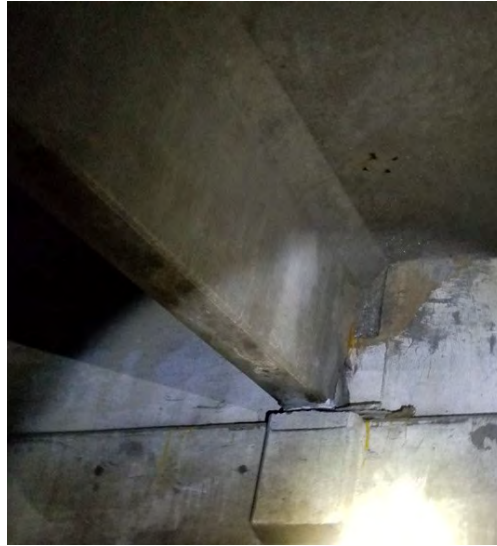

HDR evaluated the structural integrity of the rectangular, largely cast-in-place (non-pre-stressed) reservoir, in light of concrete cracking that occurred. Subsequent to initial study, five subsequent inspections and reports have been prepared to assess and monitor cracking of the concrete caused by alkali-silica reactive aggregate. 2018 recommendations included repairs to exposed footings and potential CFRP wrapping of columns and pilasters.

Ventura Water Master Plan - Bailey Reservoirs 1 & 2 Evaluations

City of Ventura | Ventura, California

Client Reference:

City of Ventura
Robert Herbst
Principal Engineer
P: (805) 406-0181
Rherbst@cityofventura.ca.us

Project Staff:

Project Manager
Dan Ellison, PE, SE
Project Engineer
Jon Paz, EIT

Similar Scope Items:

- Structural evaluation of rectangular concrete tank of similar design
- Alkali-silica reactivity caused cracking and leakage
- City avoided expensive relining of reservoir



HDR partnered with local engineering consultant MKN for the 2022 Update of the City of Ventura's Water Master Plan. HDR's emphasis was on the assessment of the infrastructure and planning for its repair, replacement, and maintenance. Work included an evaluation of Bailey Reservoirs 1 and 2, where ASR cracking had led to leakage.

Technical memoranda were prepared regarding:

- Leakage repairs at Bailey Reservoir
- Water Main Replacement, Condition Assessment and Repairs
- Tanks and Reservoir repair and coating
- Pump Stations and wells, equipment replacement
- Treatment Plants (Avenue, Bailey and Saticoy) equipment replacement and upgrades

Hill Canyon Treatment Plant Digesters 3, 2, & 1 - Evaluations and Rehabilitation

City of Thousand Oaks | Thousand Oaks, California

Client Reference:

City of Thousand Oaks
Tim Mooney
Hill Canyon Treatment Plant
Operations Manager
P: (805) 491-8141
Trmooney@toaks.org

Project Staff:

Project Manager
Dan Ellison, PE, SE
Project Management Assistance / Project Engineer
Jon Paz, EIT

Similar Scope Items:

- Demonstrated expertise in rehabilitation of concrete tanks using polymeric linings
- Minor cracking due to alkali-silica reactivity
- Performance on first project led to sole-source selection on subsequent project

HDR provided Condition Assessment, Preliminary Design, Final Design and Operational Assistance. Digester No. 3 was the first of three digesters rehabilitated by the City of Thousand Oaks. HDR was selected after a competitive process and was awarded the other two projects based on performance. Work assigned to the HDR team included external and internal assessments of structural and mechanical systems and involved sampling of concrete for degradation tests. The digester rehabilitation included replacement of piping and corroded steel components and lining of the interior surfaces above the water line.



HDR services also included assisting the client with developing a procedure for safely removing the digester from service and for successfully returning it to service. Cracking of the concrete had occurred due to severe alkali-silica reactivity, causing gas leakage and other concerns. HDR developed innovative assessment methods, which avoided the need to clean the digesters and erect scaffolding.

Rehabilitation of Lang Ranch Reservoir & Tara Reservoir

City of Thousand Oaks | Thousand Oaks, California

Client Reference:

City of Thousand Oaks
Bret Sherman
Utilities Supervisor
P: (805) 376-5050
Bsherman@toaks.org

Project Staff:

Project Manager
Dan Ellison, PE, SE
Staff Engineer
Jon Paz, EIT
Electrical Engineer
Justin Lee, PE

Similar Scope Items:

- Complex rehabilitation of tanks due to extensive corrosion damage
- Remediation of settlement issues at Tara Reservoir
- Remediation of drainage problems at Lang Ranch



Consistent with recommendations made in the 2013 Seismic Evaluation Report by HDR, services including design, preparation of contract documents, and engineering support services during bidding and construction phases were provided for the Lang Ranch Rehabilitation project. Work included:

- Flexible connections between tank and inlet/outlet pipelines
- Removal of tank interior coal-tar coatings, repair of corrosion damage, and recoat of tank interior
- Removal of tank exterior painting (lead-based), and repaint of tank exterior

- Modification to overflow weir and drain pipe to create a conventional design
- Replacing exiting roof vent with a larger and more appropriate unit
- Floor scanning/repair and galvanic anodes
- Providing new Cathodic Protection System
- Performing miscellaneous safety upgrades
- Providing necessary improvements, such as power and telemetry points of connection (SCADA) for water sampling ports, water circulation pump (mixer), etc.
- Provisions for proper removal and disposal of existing lead paint, including pre- and postconstruction lead content testing at the project site by contractor
- Providing daily coating/ painting inspection/welding inspection.



8 Certificate of Professional Liability Insurance





CERTIFICATE OF LIABILITY INSURANCE

6/1/2026

DATE (MM/DD/YYYY)

3/12/2026

THIS CERTIFICATE IS ISSUED AS A MATTER OF INFORMATION ONLY AND CONFERS NO RIGHTS UPON THE CERTIFICATE HOLDER. THIS CERTIFICATE DOES NOT AFFIRMATIVELY OR NEGATIVELY AMEND, EXTEND OR ALTER THE COVERAGE AFFORDED BY THE POLICIES BELOW. THIS CERTIFICATE OF INSURANCE DOES NOT CONSTITUTE A CONTRACT BETWEEN THE ISSUING INSURER(S), AUTHORIZED REPRESENTATIVE OR PRODUCER, AND THE CERTIFICATE HOLDER.

IMPORTANT: If the certificate holder is an ADDITIONAL INSURED, the policy(ies) must have ADDITIONAL INSURED provisions or be endorsed. If SUBROGATION IS WAIVED, subject to the terms and conditions of the policy, certain policies may require an endorsement. A statement on this certificate does not confer rights to the certificate holder in lieu of such endorsement(s).

PRODUCER Lockton Companies, LLC DBA Lockton Insurance Brokers, LLC in CA CA license #0F15767 444 W. 47th St., Ste. 900 Kansas City MO 64112-1906 (816) 960-9000 keasu@lockton.com	CONTACT NAME: PHONE (A/C No. Ext): _____ FAX (A/C No): _____ E-MAIL ADDRESS: _____	
	INSURER(S) AFFORDING COVERAGE	
INSURED 1429583 HDR ENGINEERING INC 1917 SOUTH 67TH STREET OMAHA NE 68106	INSURER A: Lloyds of London	
	INSURER B:	
	INSURER C:	
	INSURER D:	
	INSURER E:	
	INSURER F:	

COVERAGES **CERTIFICATE NUMBER:** 23143616 **REVISION NUMBER:** XXXXXXXX

THIS IS TO CERTIFY THAT THE POLICIES OF INSURANCE LISTED BELOW HAVE BEEN ISSUED TO THE INSURED NAMED ABOVE FOR THE POLICY PERIOD INDICATED. NOTWITHSTANDING ANY REQUIREMENT, TERM OR CONDITION OF ANY CONTRACT OR OTHER DOCUMENT WITH RESPECT TO WHICH THIS CERTIFICATE MAY BE ISSUED OR MAY PERTAIN, THE INSURANCE AFFORDED BY THE POLICIES DESCRIBED HEREIN IS SUBJECT TO ALL THE TERMS, EXCLUSIONS AND CONDITIONS OF SUCH POLICIES. LIMITS SHOWN MAY HAVE BEEN REDUCED BY PAID CLAIMS.

INSR LTR	TYPE OF INSURANCE	ADDL INSD	SUBR WVD	POLICY NUMBER	POLICY EFF (MM/DD/YYYY)	POLICY EXP (MM/DD/YYYY)	LIMITS
	COMMERCIAL GENERAL LIABILITY <input type="checkbox"/> CLAIMS-MADE <input type="checkbox"/> OCCUR GEN'L AGGREGATE LIMIT APPLIES PER: <input type="checkbox"/> POLICY <input type="checkbox"/> PRO-JECT <input type="checkbox"/> LOC <input type="checkbox"/> OTHER: _____			NOT APPLICABLE			EACH OCCURRENCE \$ XXXXXXXX DAMAGE TO RENTED PREMISES (Ea occurrence) \$ XXXXXXXX MED EXP (Any one person) \$ XXXXXXXX PERSONAL & ADV INJURY \$ XXXXXXXX GENERAL AGGREGATE \$ XXXXXXXX PRODUCTS - COMPIOP AGG \$ XXXXXXXX \$
	AUTOMOBILE LIABILITY <input type="checkbox"/> ANY AUTO <input type="checkbox"/> OWNED AUTOS ONLY <input type="checkbox"/> SCHEDULED AUTOS <input type="checkbox"/> HIRED AUTOS ONLY <input type="checkbox"/> NON-OWNED AUTOS ONLY			NOT APPLICABLE			COMBINED SINGLE LIMIT (Ea accident) \$ XXXXXXXX BODILY INJURY (Per person) \$ XXXXXXXX BODILY INJURY (Per accident) \$ XXXXXXXX PROPERTY DAMAGE (Per accident) \$ XXXXXXXX \$
	UMBRELLA LIAB <input type="checkbox"/> OCCUR EXCESS LIAB <input type="checkbox"/> CLAIMS-MADE <input type="checkbox"/> DED <input type="checkbox"/> RETENTION \$			NOT APPLICABLE			EACH OCCURRENCE \$ XXXXXXXX AGGREGATE \$ XXXXXXXX \$ XXXXXXXX
	WORKERS COMPENSATION AND EMPLOYERS' LIABILITY ANY PROPRIETOR/PARTNER/EXECUTIVE OFFICER/MEMBER EXCLUDED? (Mandatory in NH) If yes, describe under DESCRIPTION OF OPERATIONS below			NOT APPLICABLE			<input type="checkbox"/> Y <input type="checkbox"/> N <input type="checkbox"/> N/A PER STATUTE OTH-ER E.L. EACH ACCIDENT \$ XXXXXXXX E.L. DISEASE - EA EMPLOYEE \$ XXXXXXXX E.L. DISEASE - POLICY LIMIT \$ XXXXXXXX
A	ARCH & ENG PROFESSIONAL LIABILITY	N	N	P001412500	6/1/2025	6/1/2026	PER CLAIM: \$1,000,000 AGGREGATE: \$1,000,000

DESCRIPTION OF OPERATIONS / LOCATIONS / VEHICLES (ACORD 101, Additional Remarks Schedule, may be attached if more space is required)
RE: BACKGROUND EACH YEAR THE DISTRICT COMPLETES INSPECTIONS AND CLEANING OF 5 (OF 26) POTABLE WATER TANKS AND 3 (OF 3) OF THE RECYCLED WATER TANKS. WITH THESE INSPECTION REPORTS, AND RECOMMENDATIONS FROM TECHNICAL SERVICES, OPERATIONS, AND MAINTENANCE, THE DISTRICT MAINTAINS A TANK CONDITION ASSESSMENT AND REHABILITATION PROGRAM. THE GOAL OF THE PROGRAM IS TO IDENTIFY TANKS IN NEED OF MAINTENANCE, PRIORITIZE FROM HIGHEST TO LOWEST, AND PLAN REHABILITATION PROJECTS ACCORDINGLY.

CERTIFICATE HOLDER

CANCELLATION See Attachment

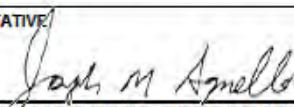
23143616 LAS VIRGENES MUNICIPAL WATER DISTRICT 4232 LAS VIRGENES RD. CALABASAS, CA 91302	SHOULD ANY OF THE ABOVE DESCRIBED POLICIES BE CANCELLED BEFORE THE EXPIRATION DATE THEREOF, NOTICE WILL BE DELIVERED IN ACCORDANCE WITH THE POLICY PROVISIONS. AUTHORIZED REPRESENTATIVE 
--	--

This endorsement, effective: 06/01/2025 - 06/01/2026

Forms a part of policy no.: P001412500

Issued to: HDR ENGINEERING INC

By: Lloyd's of London

NOTICE OF CANCELLATION TO CERTIFICATE HOLDERS ENDORSEMENT

Except with respect to cancellation for non-payment of premium (10 day notice cancellation), the **Insurers** shall give 30 days' notice of cancellation to the Certificate Holder(s) set forth herein, provided that:

1. The **First Named Insured** is required by contract to give notice of cancellation to the Certificate Holder, and
2. Prior to the **Insurers** sending its notice of cancellation to the **First Named Insured**, the **First Named Insured** shall provide the **Insurers**, in writing, either directly or through the **First Named Insured** broker of record, the name of each person or organization requiring notice of cancellation and the corresponding address for such person or for the employee responsible for receipt of notice of cancellation on behalf of such organization.

Notice of cancellation will be sent in accordance with the terms and conditions of the policy, except that the **Insurers** may provide written notice individually or collectively to the Certificate Holders by email at the current email address given by the **First Named Insured**. Proof of sending of the notice of cancellation by email shall be sufficient proof of notice.

Any failure to provide notice of cancellation to the Certificate Holder due to inaccurate or incomplete information provided by the **First Named Insured** shall remain the sole responsibility of the **First Named Insured**.

The following definitions apply to this endorsement:

1. **First Named Insured** means the **Named Insured** shown in the Declarations.

ALL OTHER TERMS AND CONDITIONS OF THE POLICY SHALL REMAIN UNCHANGED.



9 Schedule of Rates





SCHEDULE OF RATES

Below is the Schedule of Rates for the Equestrian Tank Rehabilitation Project Design team. The expanded fee can be found in the separately submitted Cost Proposal.

Description	Hourly Rate
Equestrian Tank Rehabilitation Project Team	
Principal-in-Charge	\$375
Project Manager	\$375
Quality Reviewer	\$330
Project Engineer	\$190
Sr Structural Engineer	\$250
Structural Engineer	\$180
Sr. Civil Engineer	\$280
Sr. Corrosion Engineer	\$285
Corrosion Engineer	\$180
Electrical and I&C Engineer	\$225
Safety Manager	\$250
CADD Technician	\$175
Coating Inspector - PW	\$210
Accountant	\$160
Project Coordinator	\$150



10 Matrix of Tasks/Hours





TASKS		LEVEL OF EFFORT															Total Labor
No.	Description	Principal	Project Manager	Quality Reviewer	Project Engineer	Sr. Struct. Engineer	Struct. Engineer	Sr. Civil Engineer	Sr. Corr. Engineer	Corr. Eng	Electrical/I&C Eng.	Safety Manager	CADD Technician	Coating Inspct. - PW	Acct.	Project Coord.	
1	Phase 1 - Project Initiation, data review, and site assessment																
1.1	Records review		3	3	3						3						12
1.2	Kickoff meeting	2	3		4												9
1.3	Site visit		4		4												8
1.3.1	In-tank inspections -- OPTIONAL																0
1.4	Site survey -- OPTIONAL																0
1.4.1	Analysis of main girder -- OPTIONAL																0
1.5	Project Administration		6		14										20	20	60
Subtotal 1 Phase 1		2	16	3	25	0	0	0	0	0	3	0	0	0	20	20	89
2	Phase 2 - Preliminary and Final Design																
2.1	Preliminary Engineering TM - Draft	3	22	5													30
2.1.1	Review Meeting		4	5													9
2.1.1	Preliminary Engineering TM - Final		5														5
2.2	Bid Documents (9 sheets, specs, OPCC)	6	20	17	88	9	27	44			40		198				449
2.2.1	60% submittal and review meeting		4		18			4					14				40
2.2.2	90% submittal and review meeting		4		18			4					8				34
2.2.3	100% submittal		3		8			3					9				23
Subtotal 2 Phase 2		9	62	27	132	9	27	55	0	0	40	0	229	0	0	0	590
3	Bid and Construction-Phase Services																
3.1	PreBid Meeting		2		3												5
3.2	Addenda (up to 2)		6		10												16
3.3	PreConstruction Meeting	2	2		3												7
3.4	Tech Document Reviews		14		66			23									103
3.5	Construction Progress Mtgs	2	10		10			3									25
3.6	Final Job Walk		2		4			3									9
3.7	Record Drawings				6								20				26
3.8	Site Inspections -- OPTIONAL																0
Subtotal Bid & Construction Services		4	36	0	102	0	0	29	0	0	0	0	20	0	0	0	191
TOTAL TASK HOURS		15	114	30	259	9	27	84	0	0	43	0	249	0	20	22	872
OPTIONAL TASKS		OPTIONAL LEVEL OF EFFORT															
1.3.1	In-tank inspections -- PLANNING & DOC		2		2				6	12	4			1	1		28
1.3.2	In-tank inspections -- FLOAT INSPECTION		4		4					10	10			1	1		30
1.3.3	In-tank inspections -- DRY INSPECTION + LAB TESTING		4		4					20				1	1		30
1.4	Site survey -- TOPOGRAPHIC BASE MAP		2		2			4				4		4	4		20
1.4.1	Analysis of main girder -- IF SETTLEMENT IS FOUND		2	4	1	8	32							1	1		49
3.8	Site Inspections -- AMPP LEVEL 3 INSPECTOR - 5 WEEKS		2		2				8				200	1	2		215
OPTIONAL TASK TOTAL HOURS		0	16	4	15	8	32	4	14	42	14	4	200	9	10	0	372
TOTAL HOURS FOR ALL TASKS		15	130	34	274	17	59	88	14	42	57	4	449	9	30	22	1,244



11 Professional Services Agreement Inclusions / Exclusions

If selected for the Equestrian Tank Project, HDR would request modifications to contract language related to indemnification and insurance. These changes have been previously agreed to by the District for several projects, including the recent OceanWell Onshore Infrastructure Study, the Malibou Lake Siphon Replacement Project, and the Potable Water Pipeline Condition Assessment, Rehabilitation and Replacement Study.

HDR and Las Virgenes MWD have worked together on more than two dozen projects over several decades, and have never had difficulty reaching consensus on terms and conditions.



A Appendix





A-1 Team Resumes





John Coffman, PE (CA), CCM

Principal-in-Charge

John is a professional engineer and certified construction manager with 30 years of civil engineering design, project management, estimating, and construction management experience serving municipal clients. His projects have encompassed design and construction management (CM) services for small and large-diameter potable and wastewater pipelines, reservoirs, and pump stations along with site civil and yard piping for water and wastewater treatment plants. John has extensive experience with permit coordination, bid document preparation, and engineering services during construction. With a strong background in construction, he brings a unique perspective in preparing construction documents that incorporate CM experience, resulting in plans that are concise and constructible.

EDUCATION

Bachelor of Science,
Civil Engineering,
California Polytechnic
State University, San Luis
Obispo

REGISTRATIONS & CERTIFICATIONS

Professional Engineer -
Civil, CA #C60754

Certified Construction
Manager (CCM), CA
#7219

INDUSTRY TENURE

30 years

RELEVANT EXPERIENCE

Las Virgenes Municipal Water District, Westlake Filtration Plant Expansion, Calabasas, CA

Construction Manager. John served as construction manager for the Westlake Filtration Plant Expansion Project. The treatment plant consisted of expanding the treatment plant to add two new diatomaceous earth filters, expanding the treatment plant that had been built in the late 1960s. The project also included removal of a raw water forebay and replacing it with a piping gallery, distribution piping, valve, pump and motor improvements.

Las Virgenes Municipal Water District, Westlake Pump Station, Calabasas, CA

Construction Manager. John served as construction manager for the Westlake Pump Station Project. The pump station upgrade included the replacement of gas engine driven pumps with new electrical motors and VFDs, a new 1.5MW generator, associated piping, valve, HVAC, surge control facilities, new transformer, surge tank and site improvements.

Las Virgenes Municipal Water District, 5MG Reservoir/36in Steel Pipeline, Calabasas, CA

Construction Manager and Design Engineer. John served as construction manager and design engineer for 5MG Reservoir/36in Steel Pipeline project. The project included blasting 20,000CY of granite rock adjacent to the Westlake Dam above a community that was strongly opposed to the project. Also included was the construction of rock safety netting to protect the new reservoir after 20ft near vertical cuts were completed in granite rock. Tasks also included

managing RFIs, performing change order reviews, conducting progress meetings, coordinating public outreach activities, document control, and coordinating the daily blast monitoring program. John also managed the onsite inspector who oversaw inspection of 4,000ft of 36in steel pipeline placed in a 42in steel casing across the dam and construction of the 5MG pre-stressed concrete reservoir. The project also included a substantial community outreach presence and direct coordination with Division of Safety of Dams inspectors and engineers, local officials, and District Inspection staff.

California Water Services, Harris Reservoir Replacement, Thousand Oaks, CA

Resident Engineer and Inspector. John served as resident engineer and inspector for the award-winning Harris Reservoir Replacement project. The project won the State of California American Council of Engineers (ACEC) Water Merit Award. Served as the onsite Resident Engineer through project completion. The project included a 4MG replacement potable water reservoir built within the walls of an existing pre-stressed concrete reservoir that was located on an ancient landslide, where the existing tank settled 10in. Additional aspects of the project were deep rock anchor installations, 10,000CY of cellular concrete backfill, soil cement, steel piping, a 25ft tall shotcrete wall underneath the existing 25ft tall reservoir wall, a 55ft deep blow off shaft and construction of the 55ft deep 4MG pre-stressed concrete replacement reservoir. Other tasks included performing inspections, managing RFIs, change orders,

document control and managing the settlement monitoring program throughout construction to monitor for potential landslide movement.

City of Ventura, 30in Interconnect Potable Water Pipeline, Ventura, CA

Project Manager. John led the 30% and 60% design development for 4mi of utility mapping in a very heavily congested utility corridor and the design for two miles of the Ventura Interconnect Pipeline, a 30in potable water pipeline consisting of steel and HDPE materials. Part of the scope included performing an alignment analysis considering cost, utility, traffic and constructability issues. The project included a 3,000ft long horizontal direction drill across the Santa Clara River.

Central Coast Water Authority, 36in Steel Pipe Potable Water Repairs, Buellton, CA

Project Engineer. John led the 30% and 60% design development for 4mi of utility mapping in a very heavily congested utility corridor and the design for two miles of the Ventura Interconnect Pipeline, a 30in potable water pipeline consisting of steel and HDPE materials. Part of the scope included performing an alignment analysis considering cost, utility, traffic and constructability issues. The project included a 3,000ft long horizontal direction drill across the Santa Clara River.

Cachuma Operations and Maintenance Board, 30in Line Valve Installation on Steel Cylinder Bar Wrapped Potable Water Pipe, Montecito, CA

Project Engineer. John served as project engineer for the 30in line valve installation into an existing 30in cement mortar lined and coated bar wrapped steel cylinder pipe in Montecito, CA. Work involved removal of a segment of the existing pipeline to install the valve, bypass piping and air and vacuum valve installation.

City of Ventura, VenturaWaterPure Ocean Outfall Pump Station, Ventura, CA

Project Manager. John and the HDR team provided engineering design, hydraulic modeling, cost estimating, building engineering services, and engineering services during construction for the project. The pump station will deliver 4.3mgd of ROC and 10mgd of tertiary

treated effluent through 3-600hp pumps. HDR also provided design services for a 1,600ft tsunami wall on 90 deep piles, twin 530k gallon temporary storage facilities and temporary pumping facilities. Six months into the 18-month construction schedule, City program management staff directed HDR to relocate the pump station due to their new MBR facility being relocated. HDR completed the redesign of the relocated pump station in five months.

Santa Clarita Valley Water District, Construction Manager 42in Steel Pipeline, Santa Clarita, CA

Owner's Representative. John performed as the Client's owner's representative. Two special inspectors for pipeline construction and one special inspector for welding reported to John during this project. The purpose of this contract was to perform 3rd party inspections for 6,000ft of 42in welded steel potable water pipeline, utility vaults and appurtenances. John provided detailed change order reviews, document control, response to RFIs, review of field inspection daily's, special inspection reports, and reported to the agency. He also coordinated daily with the design engineer and District inspection and Engineering staff to facilitate overall success of the project the relocated pump station in five months.

City of Santa Paula, New 4MG Pre-stressed Concrete Reservoir and Potable Water Pipeline, Santa Paula, CA

Resident Engineer and Inspector. John served as resident engineer and inspector on the City of Santa Paula's new 4mg pre-stressed concrete reservoir and 1mi potable water pipeline. The reservoir created additional potable water storage that was greatly needed on the west end of Santa Paula. The project included steel, soil cement, HDPE and ductile iron pipe placed in existing older City Streets and the Gooding Canyon adjacent to a large creek. It also included a 36in steel pipe jack and bore across VCTC railroad right-of-way for the 24in potable water pipeline. Other aspects of the project included reconstructing several City Streets effected by the construction and coordination with City Water Operations.



Dan Ellison, PE (CA), SE (CA)

Project Manager

Dan is a recognized authority on condition assessment, rehabilitation, and trenchless construction, having authored eight books on these subjects. He has managed the evaluation and design of more than six dozen tanks and reservoirs. Dan's unique qualifications for this project: Five previous evaluations of Equestrian Tank, In-depth knowledge of Backbone System hydraulics from 3 Master Plan projects, Emergency Repairs of Meadows Reservoir. He has managed the evaluation and design of more than six dozen tanks and reservoirs.

RELEVANT EXPERIENCE

EDUCATION

Master of Business Administration, Finance, University of Southern California

Bachelor of Science, Civil Engineering, University of Utah

Bachelor of Art, English, University of Utah

REGISTRATIONS & CERTIFICATIONS

Professional Engineer - Civil, CA #C38094

Structural Engineer, CA #S3020

INDUSTRY TENURE

43 years

Las Virgenes Municipal Water District, Equestrian Tank Evaluations, Calabasas, CA Project Manager. Dan evaluated the structural integrity of the rectangular, largely cast-in-place (non-pre-stressed) reservoir, in light of concrete spalling that occurred. Subsequent to initial study, five subsequent inspections and reports have been prepared to assess and monitor cracking of the concrete caused by alkali-silica reactive aggregate.

Las Virgenes Municipal Water District, Ocean Well On-shore Study, Calabasas, CA Project Manager. Dan is serving as project manager for a project that will determine general concepts for the on-shore conveyance system needed to utilize desalinated water from a submerged, offshore treatment facility. The study examines pipelines, pumping stations, and other facilities. Other project participants include Los Angeles Department Water and Power, Calleguas Municipal Water District, Los Angeles County Waterworks Districts, City of Burbank, Metropolitan Water District, and West Basin Municipal Water District.

Las Virgenes Municipal Water District, Project Alternatives Study for the 1,235ft Backbone Improvements, Calabasas, CA Project Manager. Dan served as project manager for project definition report and CEQA studies examining a series of improvements to the major transmission, storage, and supply facilities of Las Virgenes Municipal Water District. Facilities included: 10mgd interconnection with Calleguas Municipal Water District; 5MG finished storage reservoir; expansion of reservoir filtration plant; addition of UV system at filtration plant; conversion of gas-powered pump station to electrical service, with emergency generator back-up; upgrades to 30in reinforced concrete pressure pipe; and pipeline routing studies.

Las Virgenes Municipal Water District, 29 Interconnection Facilities Study, Calabasas, CA

Project Manager. Dan authored a study which evaluated pumping and pipeline alternatives for an interconnection between Las Virgenes and District 29 in Malibu Canyon Road.

Las Virgenes Municipal Water District, Calabasas, CA

- **Ranchview Tank, Project Manager and Lead Design Engineer**
- **New Millennium Pump Stations and Tanks, Project Manager**
- **Upper Twin Lakes Pump Station and Tank, Project Manager**
- **Saddle Peak and Latigo Tanks Rehabilitation, Project Manager**
- **7-Tank Evaluation Report, Project Manager**
- **Structural Assessment and Rehabilitation of Calabasas 8MG Tank, Project Manager**
- **Tapia Clarifiers 2 and 3 Rehabilitation, Project Manager**

City of Thousand Oaks, Meadows Reservoir Emergency Repairs, Thousand Oaks, CA

Project Manager. HDR was retained by the City of Thousand Oaks to investigate and rehabilitate major distress at a 3.3MG water reservoir (a virtual twin of Equestrian Tank). The reservoir, a rectangular reinforced concrete tank, originally constructed in 1973, experienced unprecedented leakage in 2021. Subsequent investigations found major settlement of two columns and associated structural distress, with the potential for a sudden, catastrophic collapse. HDR then prepared plans and specs for a fast-track emergency repair aimed at returning the tank to service before "fire season." The project was recognized by APWA as a local "Project of the Year."

City of Ventura, Bailey Reservoirs 1 and 2 Evaluation, Ventura, CA

Project Manager. As part of a 2021 Master Plan Update, HDR evaluated Bailey Reservoirs 1 and 2, where cracking of the concrete was prevalent, and leakage had been an issue. Recent repairs of floor cracks had significantly reduced the leakage from the reservoir, but an evaluation of alternative rehabilitation methods, including possible structural repairs was needed. HDR's report discussed the cause of the cracking, which stems from a mild case of alkali-silica reactivity. From a structural standpoint, the cracks were not concerning, but periodic monitoring for corrosion and other signs of potential distress will be recommended. A spray-applied polymer lining system was discussed as a potential long-term solution.

City of Thousand Oaks, Hill Canyon Treatment Plant Digesters (HCTP) No. 1, 2, and 3 Rehabilitation, Thousand Oaks, CA

Project Manager. Dan and the HDR team provided condition assessment, preliminary design, final design and operational assistance. Digester No. 3 was the first of three digesters rehabilitated by the City of Thousand Oaks. HDR was selected after a competitive process and was awarded the other two projects based on performance. Work assigned to the HDR team included external and internal assessments of structural and mechanical systems and involved sampling of concrete for degradation tests. The digester rehabilitation included replacement of piping and corroded steel components and lining of the interior surfaces above the water line.

City Thousand Oaks, Concrete Tank Rehabilitation Projects, Thousand Oaks, CA

Project Manager. Dan and the HDR team have assessed and developed plans and specs for the rehabilitation of 3 concrete tanks at Hill Canyon Treatment Plant. Digester No. 3 was the first of three digesters rehabilitated by the City, for which HDR was selected after a competitive process. HDR was subsequently awarded the other two projects based on performance. Work assigned to the HDR team included external and internal

assessments of structural and mechanical systems and involved sampling of concrete for degradation tests. The rehabilitation included replacement of piping and corroded steel components and the lining of the interior surfaces above the water line. Services included operational assistance, construction inspection and engineering services.

Long Beach Utilities Department (LBUD), Rehabilitation of Tanks 19 and 20, Long Beach, CA

Project Manager. Dan assessed the condition of Tanks 19 and 20 at the Alameda Reservoir, and prepared plans and spec for their rehabilitation. Work also included the design of a small pump station and related pipe modifications for recycled water supplemental flows, to discharge potable water through an air-gap through the roofs of three recycled water tanks. Services included construction inspection as well as engineering services during construction.

City of Thousand Oaks, Reservoir (Steel Tank) Rehabilitation Projects, Thousand Oaks, CA

Project Manager. Dan is serving as project manager for development of plans and specifications for the upgrade and rehabilitation of several tanks. Work includes removal/replacement of lead-based coatings and coal-tar coatings; upgrade of cathodic protection systems, seismic improvements, ventilation improvements, safety and security improvements, and measures to improve water quality. Work also includes the evaluation and repair of structural damage. To date, plans have been prepared for: 5MG Tara Reservoir and 3MG Lang Ranch Reservoir. Wilder Reservoir rehabilitation is in progress. Services include construction inspection as well as engineering services during construction.

Water and Recycled Water Master Plans, Las Virgenes MWD, Calabasas, CA

Project Manager. Led the analysis and development of 2000 and 2007 master plans for the potable water and recycled water systems. In 2014, led the recycled water master plan, including modeling of the Oak Park portions.



Tom Hamlin, PE (CA, MT), SE (CA, AZ, NM, HI, UT), NCEES QA/QC and Technical Advisor

Tom's 22 years of experience as a structural engineer includes condition assessments, structural investigations, design, plan development, QC reviews, and construction administration for a wide range of structure types, including water/wastewater facilities, mining, industrial, data center, and federal facilities. Tom also has extensive experience in the assessment, repair, renovation, and new construction of water/wastewater and federal facilities, including seismic evaluations and rehabilitations of existing buildings in accordance with ASCE 41. Clients that have benefited from Tom's structural expertise includes U.S. Army Corps of Engineers, Naval Facilities Engineering Systems Command, Engineering and Expeditionary Warfare Center, Lacey, Olympia, and Tumwater, in Thurston County, Washington (LOTT) Clean Water Alliance, San Diego Public Utilities, Las Vegas Valley Water District, and the Cities of Phoenix, Tucson, Scottsdale, Las Vegas, Billings, Anacortes, and Kennewick.

EDUCATION

Masters of Science,
Civil and Environmental
Engineering, South
Dakota State University

Bachelor of Science,
Civil and Environmental
Engineering, South
Dakota State University

REGISTRATIONS & CERTIFICATIONS

Professional Engineer -
Civil, CA #71864

Professional Engineer,
MT #PEL-PE-LIC-27040

Structural Engineer, CA
#S6122

Professional Engineer -
Structural, AZ #54311

Professional Engineer -
Structural, NM #23315

Professional Engineer -
Structural, HI #PE-16088

Professional Engineer -
Structural, UT
#10670513-2203

National Council
of Examiners for
Engineering and
Surveying (NCEES)
#56771

INDUSTRY TENURE

22 years

RELEVANT EXPERIENCE

City of Thousand Oaks, Meadows Reservoir Emergency Repairs, Thousand Oaks, CA

Structural Lead. HDR was retained by the City of Thousand Oaks to investigate and rehabilitate major distress at a 3.3MG water reservoir (a virtual twin of Equestrian Tank). The reservoir, a rectangular reinforced concrete tank, originally constructed in 1973, experienced unprecedented leakage in 2021.

Subsequent investigations found major settlement of two columns and associated structural distress, with the potential for a sudden, catastrophic collapse. HDR then prepared plans and specs for a fast-track emergency repair aimed at returning the tank to service before "fire season." The project was recognized by APWA as a local "Project of the Year."

City of Ventura, VenturaWaterPure Ocean Outfall Pump Station, Ventura, CA

Structural Lead. The ocean outfall and corresponding pump station will deliver a combination of reverse osmosis concentrate and tertiary treated disinfected effluent safely to the ocean. Ryan and the HDR team are providing engineering services related to the pump station that will discharge to the ocean outfall. The pump station will have the capacity to discharge a maximum of 14mgd of tertiary treated effluent from the Ventura WRF during peak wet weather events which assumes the AWWP is offline resulting in no additional RO concentrate.

Long Beach Utilities Department (LBUD), S-8 Sewer Lift Station Rehabilitation, Long Beach, CA

Structural Lead. Tom is serving as structural lead on an LBUD project that is providing design services to rehabilitate the aging S-8 Sewer Lift Station. By identifying upgrades and bringing the SLS into code compliance, the project team hopes to serve LBUD far into the future.

Orange County Sanitation District, Centrifuge Seismic Support Design at Project No. P1-101, Fountain Valley, CA

Structural Lead. Tom prepared structural calculations and drawings for seismic restraints of three new thickening centrifuges and three new dewatering centrifuges as a part of the overall OC San P1-101 project. HDR performed an engineering study; centrifuge testing, selection and procurement assistance; preliminary design; design for installation of a primary sludge and waste activated sludge co-thickening system, replacement of the existing sludge dewatering system (belt presses) with a new system (centrifuges); replacement of existing solids area odor control systems, including rehabilitation, upgrade, replacement and/or addition of associated structural, process, mechanical, electrical, and instrumentation and control systems.

**Eastern Municipal Water District,
Regional Water Reclamation Facility
Digester 2 Rehabilitation, Perris, CA**

Structural Lead. Tom served as structural lead for a project that included visual, aural, and chemical assessment of a 25ft section of the wall along with associated wedges of the floor and roof that extend from the wall to the center of the digester.

**Orange County Sanitation District,
College Pump Station Wet Well Condition
Assessment Study, Fountain Valley, CA**

Structural Lead. Tom served as structural lead for an assessment that included visual inspection, photo documentation, in-situ pH testing, corrosion potential mapping of steel reinforcement, and laboratory analyses of concrete cores for pH and chloride.

**Orange County Sanitation District
(OC San), P1-128 HDRE Headquarters
Complex, Fountain Valley, CA**

Structural Lead. Tom served as structural lead for a project that provided engineering and architectural services during the design and development of the OC San Headquarters Facility, which includes a three-story office complex, laboratory facility expansion and remodel, parking lot and pedestrian bridge over Ellis Avenue.

**South Orange County Wastewater
Authority, JB Latham Aeration and
Cogeneration Improvements,**

Dana Point, CA

Structural Lead. Tom served as structural lead for the JB Latham Aeration and Cogeneration Improvements. A seismic analysis of the existing structural system was conducted after the initial condition assessment was completed. Several deficiencies were identified in the load paths at the existing concrete walkways.

**Victor Valley Wastewater Reclamation
Authority, Otoe Lift Station Assessment
and Rehabilitation, Apple Valley, CA**

Structural Lead. Tom served as structural lead for a project that completed a condition assessment and rehabilitation of an existing sewage lift station and above-grade masonry building. Modifications included relocation of an existing diesel generator installation of CFRP strengthening installation of a new HS20 load rated concrete slab over the existing wet well and various concrete repairs.

**City of Phoenix, Concrete Reservoir
Assessment and Improvements Program,
Phoenix, AZ**

Structural Lead. Tom prepared the structural design of the roof rehabilitation and repair of the existing 20MG potable water storage reservoir based on the recommendations presented in the basis of design and condition assessment reports. HDR completed condition assessments and design services for the rehabilitation of city potable water concrete reservoirs.

**Tucson Water, Reservoir and Tank
Rehabilitation Program, Tucson, AZ**

Structural Lead. For this multi-year comprehensive asset management program, HDR provided specialized corrosion-related reservoir assessments and recommendations for rehabilitation and future inspections involving condition assessment rehabilitation design and construction administration for 34 concrete reservoirs ranging from 2MG to 60MG; and 34 steel tanks up to 2MG in size and were constructed from 1950 to the present day. Tom assisted with structural investigations of concrete reservoirs including Wilmot and Clearwell Reservoir. For Wilmot Reservoir, CFRP was used to strengthen the two-way elevated roof slab, columns, and walls. For Clearwell Reservoir, CFRP was used to strengthen the interior columns.



Ron Manske, PE (CA, WY, TX, CO), SE (CA, AZ, ID, AL) CFRP QC/Technical Advisor

Ron serves as HDR's global director of structural engineering, bringing 28 years of leadership and technical expertise to his projects. His career has specialized in the design, construction, and assessment of water and wastewater facilities, including water-bearing concrete structures, vibration-sensitive equipment, corrosive environments, and adaptive reuse. His portfolio spans potable water treatment, pipelines, pump stations, and wastewater treatment facilities. Known for fostering collaboration, active listening, and seamlessly integrating design and construction processes, Ron leverages a deep understanding of construction methodologies to deliver efficient, sustainable, and constructible solutions. He is committed to advancing the built environment through resilient and forward-thinking engineering practices.

EDUCATION

Master of Science,
Structural Engineering,
Colorado State University

Bachelor of Science, Civil
Engineering, University of
Wisconsin, Platteville

REGISTRATIONS & CERTIFICATIONS

Professional Engineer -
Civil, CA #64964

Professional Engineer -
Civil, WY #13922

Professional Engineer, TX
#93353

Professional Engineer, CO
#38655

Structural Engineer, CA
#6154

Professional Engineer -
Structural, AZ #71523

Professional Engineer -
Structural, ID #21207

Professional Engineer -
Structural, AL #53654

INDUSTRY TENURE

28 years

RELEVANT EXPERIENCE

City of Westminster, Northridge Tanks, Westminster, CO

Lead Structural Engineer. Ron and the HDR team provided demolition of the existing tanks, design of the new tanks, and associated civil and yard piping improvements. Significant public outreach was required due to the proximity of nearby homeowners. The team also completed land acquisition of a stranded parcel adjacent to the site. A CMAR was brought onboard early in design to support tank siting alternatives analysis, develop construction costs, and provide project sequencing and constructability reviews.

City of Boulder, Betasso Water Treatment Plant Assessment, Design, and Construction, Boulder, CO

Structural Engineer-of-Record. HDR provided design services for upgrades and improvements to the existing treatment facility. The facility includes large concrete structures constructed in the 1960s/1970s, extending 25ft below grade. Upgrades to pretreatment and filtration required significant structural modifications, including rehabilitation of existing concrete structures, demolition and reconstruction of structures while keeping the plant operational directly adjacent to areas of construction, and retrofit for new treatment technologies that included strengthening of existing structures. Ron served as lead structural engineer, first providing a comprehensive structural assessment of the plant, then leading structural design of significant rehabilitation, strengthening, and new structures.

City of Arvada, Storage Tank, Arvada, CO Lead Structural Engineer.

The City hired HDR to conduct an analysis that included condition assessments on a portion of the existing tanks, identified the number of tanks to be replaced within the next 10 years, evaluated the feasibility of reusing sites or relocating, and provided an estimate for the cost of replacing these tanks.

National Park Service (NPS), Trans- canyon Water System Infrastructure Replacement Program IDIQ, Grand Canyon, AZ

Structural Engineer. Ron led the structural design for several projects and structures at the Grand Canyon, including Havasupai Gardens (formerly Indian Gardens) pump stations, Phantom Ranch's new water treatment plant (WTP), structural supports for the new Trans-canyon Waterline, and is the lead structural engineer for the North Rim infrastructure improvements.

Metro Water Recovery Denver, PWC System Improvements (PAR 1212), Denver, CO

Lead Structural Engineer. HDR provided preliminary design, final design, and construction phase services to improve the to improve the reliability and redundancy within the PWC system and to provide backup water sources to those processes that would be at risk of failure without PWC. Ron supported the design and construction services for modifications to the PWC pump station to increase capacity to 14.8mgd, including new VFD power distribution and mechanical support facilities.

Metro Water Recovery Denver, PWC South Platte Interceptor (PAR 1088), Denver, CO

Lead Structural Engineer. Ron was responsible for the structural engineering for the preliminary and final design of a new interceptor sewer and force main to serve the new NTP. The project involved the preliminary design of the South Platte Interceptor, and the effluent pump back (EPB) force main. The project included 7.5mi of SPI interceptor with diameters from 30-84in. EPB portion of the project includes 11mi of 30in pipeline routed through both urban and rural areas.

City of Greeley, Boyd Lake and Bellvue Water Treatment Plants, Facility Assessment, Final Design, and Construction Administration Projects, Greeley, CO

Structural Engineer-of-Record (EOR). HDR worked with the City to evaluate both of their treatment plants (Boyd Lake and Bellvue) to determine or confirm planned capital improvements, prioritize the improvements, and provide cost estimates with project design and construction schedules so that the City could make appropriate upgrades to the plants over a multi-year period. Ron served as structural EOR on the project and provided a comprehensive structural review of both facilities, identifying areas needing both short-term and long-term improvements. Structures included concrete and masonry buildings, pre-engineered metal buildings, concrete tanks up to 80 years-old, buried vaults, drying beds, and equipment support structures.

City of Westminster, Semper HSPS Repair and Rehabilitation (R&R), Westminster, CO

Lead Structural Engineer. The HSPS pumps finished water from the Semper WTP into the distribution system with a series of 400hp and 600hp pumps. The HSPS electrical system is approximately 25 years-old and is reaching the end of its service life. The City engaged HDR to develop a plan for upgrading the electrical system. The design will replace the majority of the electrical equipment in the pump station, including medium-voltage motor controllers, while maintaining ongoing pump station operation. A

key feature of the upgrade concept is repurposing an existing room in the HSPS to contain new electrical equipment, thereby avoiding a costly expansion to the pump station building. Ron served as lead structural engineer and designed modifications to existing buildings to strengthen them for new equipment.

Town of Breckenridge, North Water Treatment Plant (WTP), Breckenridge, CO

Lead Structural Engineer. HDR completed design for a second WTP for the town. With an ultimate capacity of 4.5mgd, the plant includes a raw water pump station to transfer water from the Blue River to the plant, three treatment trains, a residuals facility, an administration building, and a high service pump station to the town water supply. The project is in a high-profile area of the town with building aesthetics playing a key factor in the design. Ron served as lead structural engineer for the project, leading and participating in all aspects of structural design, selection of building systems, and constructability reviews.

City of Boulder, 63rd Water Treatment Facility HSPS, Boulder, CO

Lead Structural Engineer. A multi-disciplinary team completed a thorough inspection of the existing equipment, structure, and supporting utilities to identify the extent of improvements required beyond mere process improvements. Following the field investigation, alternatives were developed for different pump station configurations to improve the reliability, maintainability, and safety of the process. Through a series of workshops, these alternatives were presented, developed, and evaluated with the ultimate selection of replacing the existing pump station with new closed can pumps. Ron is serving as the lead structural engineer and structural engineer of record, designing structural improvements and retrofits to the existing pump station to facilitate new pumps, pipes, electrical gear, egress improvements, mechanical units, and equipment removal.



Jon Paz, ENV SP, EIT

Project Engineer

Jon engineers solutions to address water/wastewater infrastructure and management challenges to meet the needs of the present while planning for the future. Jon is driven, dedicated, and proactive with a proven record in engineering effective solutions that positively contribute to the client's long-term goals. He is highly organized, enthusiastic and effective in communication, and anticipates the needs of team members and clients. Jon's responsibilities include leading the development of detailed designs, specifications, and calculations; writing and reviewing preliminary design, alternatives analysis, and study-level reports; preparing cost estimates; and reviewing and responding to construction submittals and requests for information. Jon is also responsible for project management, resource allocation, budgeting and reporting, proposals and client development, subconsultant coordination, and documentation control.

EDUCATION

Master of Science,
Engineering
and Technology
Management, Colorado
School of Mines

Bachelor of Science,
Environmental
Engineering, Colorado
School of Mines

REGISTRATIONS & CERTIFICATIONS

Envision Sustainability
Professional, CA #32631

Engineer-in-Training, CO
#73511

INDUSTRY TENURE

7 years

RELEVANT EXPERIENCE

City of Thousand Oaks, Meadows Reservoir Emergency Repairs, *Thousand Oaks, CA*

Project Management Assistance/Project Engineer. HDR was retained by the City of Thousand Oaks to investigate the cause of major leakage at this 3.3MG concrete water reservoir. HDR provided engineering services including an assessment of the structural condition of the reservoir, final design for the rehabilitation, and services during construction. Based on HDR's inspection, the cause of the leakage was identified and structural distress of the reservoir was confirmed. The repair of the reservoir was confirmed to be emergent and HDR worked directly with City staff and the Contractor. Jon assisted in the development of plans and specifications and provided project management assistance including resource planning, scheduling, and Client coordination. Work included engineering assistance during construction, including the issuance of work directives, review of time and material tickets, and inspection of coatings and structural repairs.

City of Thousand Oaks, Hill Canyon Treatment Plant Digesters (HCTP) No. 1, 2, and 3 Rehabilitation, *Thousand Oaks, CA*

Project Management Assistance/Project Engineer. Jon led the development of plans and specifications, the opinion of probable construction cost, and provided project management assistance for all three digesters. Work included engineering assistance during bid and construction

phases, including the inspection of coatings and repairs for all three digesters. HDR provided engineering services to assess the condition of Digesters No.1, 2, and 3 at the HCTP and developed plans and specifications for their rehabilitation. Work included external and internal assessments of structural and mechanical systems and involved sampling of concrete. Rehabilitation work included coatings rehabilitation, piping modifications, and other improvements to one steel and two concrete biogas digesters. Once the preferred alternative is selected, HDR will prepare plans, specifications, and opinion of probable construction cost. HDR will also provide support during the bidding and construction phases of the project.

City of Thousand Oaks, Wilder Reservoir Improvements, *Thousand Oaks, CA*

Project Manager/Project Engineer. Jon led the development of plans and specifications, the opinion of probable construction cost, and project management duties including invoicing and progress reporting, resource planning, scheduling, and client coordination. HDR provided engineering services including preliminary design, final design, bidding, and construction phase services including inspection of coatings and repairs. Work included assessment of structural and mechanical components of the 1MG steel reservoir and reservoir site. The scope of work was amended to include installation of a permanent generator and improvements to the Wilder Pump Station building for the

purpose of fire hardening. Jon served as project engineer during preliminary design and a portion of final design and as deputy project manager once the scope was amended to include the permanent generator and fire hardening.

City of Ventura, Bailey Reservoirs 1 and 2 Evaluations, Ventura, CA

Project Engineer. As part of a 2021 Master Plan Update, HDR evaluated Bailey Reservoirs 1 and 2, where cracking of the concrete was prevalent, and leakage had been an issue. Recent repairs of floor cracks had significantly reduced the leakage from the reservoir, but an evaluation of alternative rehabilitation methods, including possible structural repairs was needed. HDR's report discussed the cause of the cracking, which stems from a mild case of alkali-silica reactivity. From a structural standpoint, the cracks were not concerning, but periodic monitoring for corrosion and other signs of potential distress will be recommended. A spray-applied polymer lining system was discussed as a potential long-term solution.

Long Beach Utilities Department, Tank Assessment and Master Plan, Long Beach, CA

Project Engineer. Jon and the HDR team provided structural and condition assessment of 36 potable and recycled water reservoirs, including several that date to 1920s, when seismic requirements were minimal. The team developed a Master Plan for tank maintenance and retrofit, including recommendations for seismic retrofit, structural rehabilitation, coating replacement, and other concerns. Condition assessment was performed by dive and dry-foot inspections, as well as current-demand testing of CP systems.

City of Thousand Oaks, Tara Reservoir Rehabilitation, Thousand Oaks, CA

Staff Engineer. Jon and the HDR team developed plans and specifications for the upgrade and rehabilitation of a 5MG steel tank. Work included removal/replacement of lead-based coatings and coal-tar coatings; upgrade of cathodic protection systems, seismic improvements, ventilation improvements, safety and security improvements, and measures to

improve water quality. Work also included the evaluation and repair of structural damage. Services included construction inspection as well as engineering services during construction.

City of Thousand Oaks, Lang Ranch Reservoir Rehabilitation, Thousand Oaks, CA

Staff Engineer. Jon and the HDR team developed plans and specifications for the upgrade and rehabilitation of a 3MG steel tank. Work included removal/replacement of lead-based coatings and coal-tar coatings; upgrade of cathodic protection systems, seismic improvements, ventilation improvements, safety and security improvements, and measures to improve water quality. Work also included the evaluation and repair of structural damage. Services included construction inspection as well as engineering services during construction.

Long Beach Water Department, Alamitos Tanks 19 and 20 Rehabilitation, Long Beach, CA

Project Management Assistance/Project Engineer. HDR assessed the condition of Tanks 19 and 20 at the Alamitos Tank Farm, and prepared plans and specifications for their rehabilitation. Work also included the design of a small pump station and related pipe modifications for recycled water supplemental flows, to discharge potable water through an air-gap through the roofs of three recycled water tanks. Services also included construction inspection, field engineering, and engineering services during construction. Jon led the preparation of plans, specifications, and OPCC. He also provided project management assistance, monitoring and reporting, coordination of inspection staff, and review of submittals and RFIs during construction.



James Kelly, PE (CA)

Site Improvements

James Kelly is a seasoned water and wastewater engineering professional with 11 years of industry experience and a strong track record of leading complex infrastructure projects from planning through delivery. He combines technical expertise with clear communication, proactive risk management, and a collaborative leadership style that keeps multidisciplinary teams aligned and motivated. James consistently builds strong client relationships, anticipates challenges before they impact schedules, and ensures that design, regulatory, and construction requirements are met with precision. His commitment to quality, safety, and efficient execution makes him a highly reliable and effective asset.

EDUCATION

Bachelor of Science,
Civil Engineering (Water
Resources), California
Polytechnic State
University, San Luis
Obispo

REGISTRATIONS & CERTIFICATIONS

Professional Engineer -
Civil, CA #88317

INDUSTRY TENURE

11 years

RELEVANT EXPERIENCE

City of Ventura, VenturaWaterPure Ocean Outfall Pipeline, Ventura, CA
Project Engineer. James and the HDR team designed and provided engineering services during construction for the Ocean Outfall project. The \$58M project consists of a new Ocean Outfall discharging reverse osmosis concentrate and tertiary treated effluent off the coast of Ventura. The project includes the installation of 13,000LF of 20in HDPE pipeline, replacement of a dual sewer force main, two 15ft-deep pigging vaults, and two complex horizontal directional drill operations, including one over a mile offshore to the Outfall's diffuser field. In addition to submittal and RFI responses, James was the first contact and boots on the ground for all construction questions or conflicts with the conveyance and force main lines.

United Water Conservation District (UCWD), Freeman Conveyance System Upgrade, Ventura County, CA
Project Manager. James and the HDR team are providing upgrades to UCWD's Freeman Conveyance System from Freeman to Ferro Recharge Basin. The project includes dual 60in RCP microtunneling beneath Caltrans right-of-way, sluice gates, and concrete discharge structures.

City of Camarillo, Pleasant Valley Force Main and Pump Station, Camarillo, CA
Project Manager. James and the HDR team are providing preliminary design, final design, and supplementary pump station analysis for the construction of a 26in HDPE forcemain in Pleasant Valley Road. James and team also performed condition analysis and provided potential solutions to address system issues at the City's Pump Stations No. 3 and No. 5.

Metropolitan Water District, Sepulveda Feeder Pre-stressed Concrete Cylinder Pipe (PCCP) Rehabilitation - Reach 9/ Chatsworth, Los Angeles, CA

Project Engineer. James and the team are providing professional services to perform final design and additional design services as needed for the PCCP rehabilitation of the Sepulveda Feeder. Services will consist of preparation of preliminary designs, construction drawings, specifications, construction cost estimates, bid support services, and other related professional services.

City of San Diego, Jamacha Drainage Channel Upgrade, San Diego, CA
Project Engineer. James and the HDR team are conducting an in-depth evaluation of current flooding and sediment/erosion issues, develop potential improvement alternatives, and perform final design for the segment of Jamacha Channel between Imperial Avenue and Beacon Street. The scope of work includes initial site investigations, pre-design, design services, and bid and award support services. The range of flood conveyance type improvements could include upsizing/replacing culverts at five crossings, re-grading the channel sides and profile and the use of drop structures. The project also includes stream rehabilitation and mitigation opportunities.



Ryan Wright, PE (CA, AZ, NV, ID)

Structural Engineer

Ryan is a professional engineer with structural engineering experience. His primary duties include producing structural calculations, reviewing structural calculations developed by others, conducting structural investigations, and preparing structural details, reports, and specifications. He performs routine engineering assignments requiring the application of standard techniques and procedures. Ryan's project experience includes water treatment, wastewater treatment, and industrial and mining facilities. Through this experience, Ryan has developed an understanding of water reservoir inspection and rehabilitation design, mining industry assignments, and building design. He works independently on small-to-medium-size projects as well as assists other engineers on larger, more complex projects.

EDUCATION

Master of Science, Civil Engineering, Morgan State University

Bachelor of Science, Civil Engineering, Morgan State University

REGISTRATIONS & CERTIFICATIONS

Professional Engineer, Civil, CA #98818

Professional Engineer, Civil, AZ #62528

Professional Engineer, Civil, NV #030882

Professional Engineer, Civil, ID #P-22477

INDUSTRY TENURE

20 years

RELEVANT EXPERIENCE

City of Thousand Oaks, Meadows Reservoir Emergency Repairs, Thousand Oaks, CA

Structural Engineer. HDR was retained by the City of Thousand Oaks to investigate and rehabilitate major distress at a 3.3MG water reservoir (a virtual twin of Equestrian Tank). The reservoir, a rectangular reinforced concrete tank, originally constructed in 1973, experienced unprecedented leakage in 2021. Subsequent investigations found major settlement of two columns and associated structural distress, with the potential for a sudden, catastrophic collapse. HDR then prepared plans and specs for a fast-track emergency repair aimed at returning the tank to service before "fire season." The project was recognized by APWA as a local "Project of the Year."

Orange County Sanitation District (OC San), Dewatering and Odor Control at Plant No. 1 Job No. P1-101, Fountain Valley, CA

Structural Engineer. OC San is implementing a \$2.4B program to provide full secondary treatment at Plants No. 1 and No. 2 supply water to the Groundwater Replenishment facility and improve the condition and reliability of its treatment plants. A key component of the program is the construction of new thickening and dewatering facilities at Plant No. 1. The project includes the design and construction support services for replacement of the existing sludge dewatering systems with a new system. Ryan assisted with the review process of shop drawings and RFIs for various disciplines.

City of Ventura, Ocean Outfall Pump Station, Ventura, CA

Structural Engineer. The ocean outfall and corresponding pump station will deliver a combination of reverse osmosis concentrate and tertiary treated disinfected effluent safely to the ocean. Ryan and the HDR team provided engineering services related to the pump station that will discharge to the ocean outfall. The pump station will have the capacity to discharge a maximum of 14mgd of tertiary treated effluent from the Ventura WRF during peak wet weather events which assumes the AWPf is offline resulting in no additional RO concentrate.

City of San Mateo, Nutrient Removal and Wet Weather Flow Management Upgrade and Expansion, San Mateo, CA

Structural Engineer. Ryan designed the headworks and odor control structures, and checked structural calculations developed by others. HDR provided design and engineering services during construction for the City of San Mateo Clean Water Program, Nutrient Removal and Wet Weather Flow Management Upgrade and Expansion Project.

Irvine Ranch Water District, Michelson Water Recycling Plant (MWRP) Tertiary Filters Improvements, Irvine, CA

Structural Engineer. Ryan and the HDR team provided preliminary design and final design of improvements to the tertiary filters, backwash supply system, air scour blower, and relevant electrical and instrumentation systems at the MWRP to improve treatment efficiency and system reliability. A new electrical building was provided to house the new electrical

and instrumentation equipment for the backwash supply system. New ductbank, programmable logic controller cabinet (PLC-810), and canopy were also included. Ryan served as a structural engineer for this project.

City of Phoenix, Steel Tank Reservoir Rehabilitation Program, Phoenix, AZ
Structural Engineer. HDR developed of a program to inspect and rehabilitate the City's inventory of 40+ steel water storage tanks. HDR conducted the design for each tank rehabilitation and provided CA&I services for the construction of improvements. HDR performed warranty dry inspections one year after rehabilitations to identify and repair any areas of the tank that were under warranty. Ryan served as a structural engineer for this project.

Clark County Water Reclamation District, Flamingo Water Resource Center (FWRC) Preliminary and Primary Treatment Improvements, Las Vegas, NV
Structural Engineer. HDR completed the design, and construction is currently underway for preliminary and primary treatment improvements for additional hydraulic and treatment capacity at the Clark County Water Reclamation District FWRC in Las Vegas, Nevada. This additional capacity to 150mgd average annual flow (25mgd annual average flow expansion) will accommodate population growth projections and wastewater flow increases in the district's service area. Ryan served as a structural engineer for this project.

City Of Pocatello, Water Pollution Control Facilities Improvements Phase 1, Pocatello, ID
Structural Engineer. HDR provided design services for the selected treatment facilities to implement Phase 1 which includes enhanced biological nutrient removal, chemical addition, tertiary dual media filtration, biosolids lagoon return flow management, headworks improvements and UV disinfection. Ryan assisted with producing structural calculations and reviewed structural calculations developed by others.

Tucson Water, Reservoir and Tank Rehabilitation Program, Tucson, AZ
Structural Engineer. For this multi-year comprehensive asset management program, HDR provided specialized corrosion-related reservoir assessments and recommendations for rehabilitation and future inspections involving condition assessment rehabilitation design and construction administration for 34 concrete reservoirs ranging from 2MG to 60MG; and 34 steel tanks up to 2MG in size and were constructed from 1950 to the present day. Ryan assisted with structural investigations of concrete reservoirs including Wilmot and Clearwell Reservoir. For Wilmot Reservoir, CFRP was used to strengthen the two-way elevated roof slab, columns, and walls. For Clearwell Reservoir, CFRP was used to strengthen the interior columns.



Vince Morello, PE (AZ)

Structural Engineer

Vince offers 7 years of experience in structural engineering. His experience includes the structural design and construction phase support of reservoir rehabilitations, steel tank rehabilitations, water treatment plants, lift stations, and vaults. He also has experience in performing field inspections of concrete water reservoirs and steel tanks.

RELEVANT EXPERIENCE

EDUCATION

Master of Science,
Structural Engineering,
University of Alabama at
Birmingham

Bachelor of Science, Civil
Engineering, University of
Arizona

REGISTRATIONS & CERTIFICATIONS

Professional Engineer -
Civil, AZ #78535

INDUSTRY TENURE

7 years

City of Thousand Oaks, Meadows Reservoir Emergency Repairs, Thousand Oaks, CA

Assistant Structural Engineer. HDR was retained by the City of Thousand Oaks to investigate and rehabilitate major distress at a 3.3MG water reservoir (a virtual twin of Equestrian Tank). The reservoir, a rectangular reinforced concrete tank, originally constructed in 1973, experienced unprecedented leakage in 2021. Subsequent investigations found major settlement of two columns and associated structural distress, with the potential for a sudden, catastrophic collapse. HDR then prepared plans and specs for a fast-track emergency repair aimed at returning the tank to service before "fire season." The project was recognized by APWA as a local "Project of the Year." Vince designed the new reservoir interior support wall to prevent further settlement of the structure, and assisted in drawing production on this project.

City of Thousand Oaks, Wilder Reservoir Improvements, Thousand Oaks, CA

Lead Structural Engineer. Vince and the HDR team provided engineering services including preliminary design, final design, bidding, and construction phase services including inspection of coatings and repairs. Work included assessment of structural and mechanical components of the 1MG steel reservoir and reservoir site. The scope of work was amended to include installation of a permanent generator and improvements to the Wilder Pump Station building for the purpose of fire hardening. Vince designed a new retaining wall and generator foundation on this project.

Tucson Water, Reservoir Amendment 17, Tucson, AZ

Assistant Structural Engineer. This multi-year program involved condition assessment, rehabilitation design, and construction administration for the upgrade of Tucson Water's 34 concrete reservoirs, and 34 steel storage tanks. Facilities to be rehabilitated under this program range from less than 1MG to 60MG, and were constructed from 1950 to the present day. The program includes all potable and reclaimed water storage facilities within the Tucson Water system. These water containing structures represent approximately \$250M in total assets. Vince performed field inspections of the reservoirs, wrote condition assessment reports, and designed structural repairs and retrofits for the reservoirs on this project.

Clark County Water Reclamation District, Flamingo Water Resource Center (FWRC) Preliminary and Primary Treatment Improvements, Las Vegas, NV

Assistant Structural Engineer. Vince and the HDR team completed design and construction are currently underway for preliminary and primary treatment improvements for additional hydraulic and treatment capacity at the Clark County Water Reclamation District FWRC in Las Vegas, NV. These improvements align with recommendations in the District's Pre-Design and Master Plan that HDR completed in 2019. This additional capacity to 150mgd average annual flow (25mgd annual average flow expansion) will accommodate population growth projections and wastewater flow increases in the district's service area. The estimated construction cost is \$180M with construction manager at risk as the delivery method. Vince performed the design for multiple structures including clarifier basins, the odor control canopy, mechanical platforms, site retaining walls, odor control beds, and pedestrian bridges on this project.

Tucson Water, Escalante Reservoir,
Tucson, AZ

Assistant Structural Engineer. The Escalante Reservoir project was to provide design plans and specifications for the rehabilitation of the reservoir. The reservoir had degradation of structural elements, coatings, liner, roof structure, and ventilation. The scope included improvements to measurement as well as SCADA controls. Scope was later added for construction administration, inspection, and support. The project was completed in 2024. Vince performed the design of a new roofing system and other seismic structural upgrades, and assisted in drawing production on this project.

Las Vegas Valley Water District, Wells 124 and J8 Rehabilitation Improvements,
Las Vegas, NV

Lead Structural Engineer. Vince and the HDR team are providing detailed design, bidding, and construction phase services. The services include: new well pump, piping and appurtenances, and concrete foundation; new concrete foundation; new well pump, motor, and shaft; piping and appurtenances from Well 124 to the existing pipeline; piping and appurtenance for disinfection; appurtenances and connections for well wastewater; perimeter wall to separate public space; new electrical conduits, wires, boxes, and fittings; new electrical distribution equipment, motor starters, programmable logic controller (PLC), and instrumentation; site grading to accommodate equipment; site lighting; cathodic protection for buried pipe; and site restoration at Well 124. Vince performed the design for several pipe support configurations and mechanical equipment foundations on this project.

City of Phoenix, Concrete Reservoir Program,
Phoenix, AZ

Lead Structural Engineer. HDR has provided reservoir assessment and rehabilitation services for the City of Phoenix since 2000. Since July 2000, the City has rehabilitated or has begun the rehabilitation of 14 large capacity concrete reservoirs. Vince and the team provided system-wide concrete reservoir condition assessment and rehabilitation prioritization. Vince performed field inspections of the reservoirs and wrote condition assessment reports on this project.

Tucson Water, Aerospace Parkway Transmission Main,
Tucson, AZ

Assistant Structural Engineer. HDR conducted the design of 4mi of 24in ductile iron pipeline and 0.5mi of 16in PVC pipeline. The project was split into three segments, each designed by a separate consultant under the Client's Distribution Design On-call contract. Splitting the project into three segments allowed Tucson Water to expedite the design and phase construction to meet schedule milestones associated with regional development of the Aerospace Corridor. Vince designed a pipe and equipment vault, and assisted in drawing production on this project.



Sean Hoss, PE (CA), AMPP CIP1, PACP

Optional In-Tank Inspections

Sean is a senior project manager providing design and inspection services for various wastewater and water projects throughout California. He has extensive experience with concrete condition assessment and pipeline condition assessment of drainage in dams, storm drains, and sewers. He used rope access for six years to inspect spillways and water/wastewater treatment structures. His experience includes water and wastewater treatment, facility design and inspection, municipal sewer and water system inspections, construction administration, and environmental site investigations.

EDUCATION

Bachelor of Science, Civil Engineering, California State Polytechnic University, Pomona

REGISTRATIONS & CERTIFICATIONS

Professional Engineer - Civil, CA #79964

AMPP - Coating Inspector Level 1 #103296

NASSCO Pipeline Assessment and Certification Program #P0033418-082021

NASSCO Manhole Assessment Certification Program (MACP) #P0033418-082021

NASSCO Lateral Assessment and Certification Program (LACP) #P0033418-082021

INDUSTRY TENURE

17 years

RELEVANT EXPERIENCE

Irvine Ranch Water District, Michelson Water Recycling Plant Backwash Tank Condition Assessment, Irvine, CA

Field Lead/Rope Access Lead. Sean was the field lead and rope access lead for the comprehensive condition assessment of two steel-reinforced concrete tanks at Irvine Ranch Water District's Michelson Water Recycling Plant. The project visual inspections, photo documentation, in-situ pH testing, corrosion-potential mapping of steel reinforcement, and laboratory analyses of concrete cores for pH and chloride. The assessment determined that portions of the tank walls needed concrete replacement for one-inch thickness while others required concrete replacement more than an inch beyond the reinforcement.

Orange County Sanitation District, College Pump Station Wet Well Condition Assessment Study, Costa Mesa, CA

Project Engineer. Sean and the HDR project team performed a condition assessment of the College Pump Station. Sean was the field lead and rope access lead for a comprehensive condition assessment of a wet well constructed in 1960 and rehabilitated in 2010. The wet well could only be taken out of service during the daytime, so HDR utilized rope access to descend a 13ft-long shaft and inspect the 15ft-high walls without installing scaffolding. The assessment included visual inspection, photo documentation, in-situ pH testing, corrosion-potential mapping of steel reinforcement, and laboratory analyses of concrete cores for pH and chloride. The assessment determined that limited areas of new coating had failed and the exposed concrete was damaged by acid attack but the concrete protected by an intact coating was still sound.

Eastern Municipal Water District, Temecula Valley Regional Water Reclamation Facility Biofilter Concrete Condition Assessment, Temecula, CA

Project Manager. Sean and the HDR project team evaluated the condition of a biofilter located on the Temecula Valley Regional Water Reclamation Facility. The corrosion potential of the steel reinforcement was mapped and used to select locations for concrete core samples to be tested for chloride and hydroxide in HDR's Claremont laboratory. The assessment found the concrete chemistry indicated that chloride concentrations high enough to overcome the passivating effect of high pH concrete were present at steel reinforcement depth.

Metropolitan Water District, Lake Matthews Forebay Headworks Valve Structure Condition Assessment, Riverside County, CA

Field Lead. Sean led a team to assess the concrete condition of the Lake Matthews forebay outlet structure in seven days. The reinforced concrete structure is normally partly submerged in the potable water forebay pool outside the Lake Matthews reservoir. The team used rope access work positioning, a boom lift, and a crane with a bird cage to evaluate over 6,300ft² of elevated structure. The assessment included visual inspections, concrete sounding, pH testing, rebar locating via surface penetrating radar, and half-cell potential mapping to locate corroding rebar. Concrete cores were collected and analyzed by HDR's laboratory for concrete condition. Rehabilitation options were recommended to extend the service life.

Eastern Municipal Water District, Moreno Valley Regional Water Reclamation Facility Acid Phase Digester, Moreno Valley, CA

Project Manager. Sean and the project team evaluated the condition of Eastern Municipal Water District Acid Phase Digester located on the Moreno Valley Regional Water Reclamation Facility in Moreno Valley, California. The corrosion potential of the steel reinforcement was mapped and used to select locations for concrete core samples to be tested for chloride and hydroxide in HDR's Claremont laboratory. Reinforcing steel was located using surface penetrating radar. Sean was the field lead and rope access lead for a comprehensive condition assessment of four cells of the digester.

Long Beach Utilities Department (LBUD), Reservoir Condition Assessment, Long Beach, CA

Inspection Lead. As a subconsultant to DRP Engineering, Sean and the HDR team completed an investigation of a 14MG reinforced concrete cistern, built in 1959 and located within LBUD's Water Treatment Plant in Long Beach, CA. The investigation focused on potential joint leaking and the integrity of rebar and concrete. A key project challenge included the subject cistern, which has 15ft vertical walls that transition into 20% slopes, which in turn transition to a zero slope slab. Access to the vertical portions was achieved using HDR personnel trained in rope access, which granted a quick and cost-effective solution.

Irvine Ranch Water District, Baker Water Treatment Plant Construction Management, Lake Forest, CA

Field Engineer. Sean was the field engineer for construction of a water treatment plant designed to treat 28mgd with microfiltration and ultraviolet disinfection. Sean processed nearly 1,000 RFIs and directly responded to 250 RFIs by reviewing the contract documents and district standard plans to resolve the contractor's questions. Sean inspected the steel reinforcement for the reinforced concrete structures and reviewed the concrete compressive strength tests to verify compliance with design criteria.

Orange County Sanitation District, Activated Sludge 1 and Secondary Clarifier Rehabilitations (P1-140), Orange County, CA

Condition Assessment and Inspection.

This project will perform a comprehensive rehabilitation of the Activated Sludge Facility No. 1 at Plant No. 1. This project will demolish the Primary Effluent Pump Station No. 1 and associated piping, replace all major mechanical, electrical and instrumentation equipment and perform structural rehabilitation. Sean led the task to evaluate the aeration basins, secondary clarifiers, RAS wet wells, influent splitter box, and RAS splitter boxes.

Camarillo Sanitary District, Digester Condition Assessment, Camarillo, CA

Project Manager. HDR evaluated the condition of two digesters for the City of Camarillo. Reinforcing steel was located using surface penetrating radar. The corrosion potential of the steel reinforcement was mapped and used to select locations for concrete core samples to be tested for chloride and hydroxide in HDR's corrosion laboratory. Using a data-driven approach provided the owner with insight that enabled them to plan to rehabilitate one digester and convert the other one into a storage tank. Sean was the project manager for the comprehensive condition assessment of both digesters.

NAVFAC, Navy Wastewater Treatment Plant (WWTP) at Fort Kamehameha - Facilities Plan, Pearl Harbor, HI

Project Manager. Sean was the field lead for a comprehensive condition assessment of seven steel-reinforced concrete tanks at the Joint Base Pearl Harbor Hickam Wastewater Treatment Plant. Two primary clarifiers, one aeration basin, two secondary clarifiers, one tertiary filter, and one digester were assessed. Concrete chloride permeation, steel reinforcement corrosion potential, and lab testing contributed to the structural evaluation element of the project to develop a facility plan to address storm surge, sea level rise and tsunami inundation; identify the system needs and useful economic life of the components of the WWTP.



Justin Lee, PE (CA)

Electrical, I&C, Security

Justin has more than 10 years of experience designing electrical and instrumentation plan drawings and specifications for water and wastewater treatment facility projects. This includes power plans, one-line diagrams, elevations, details, panel schedules, control diagrams, and process and instrumentation diagrams. He has provided engineering services during construction for several projects that includes reviewing submittals, responding to RFIs, and preparing revised drawings.

RELEVANT EXPERIENCE

EDUCATION

Bachelor of Science,
Electrical Engineering,
California State
University, Fullerton

REGISTRATIONS & CERTIFICATIONS

Professional Engineer -
Electrical, CA #24124

INDUSTRY TENURE

10 years

City of Thousand Oaks, Hill Cayon Treatment Plant Tertiary Filters

Rehabilitation, Thousand Oaks, CA

Lead Electrical Engineer. Justin and the HDR team are providing engineering services including condition assessment, preliminary design, final design, bidding, and construction phase services. Work includes assessment of structural, mechanical, and electrical systems, both on the top deck and in the pipe gallery, for 10 tertiary filters. Rehabilitation work includes replacement of filter equipment and media; piping, valves, and pumps; air mixing system components; electrical transformers, panels, and conduit; concrete repairs; and instrumentation.

City of Thousand Oaks, Wilder Reservoir Improvements, Thousand Oaks, CA

Lead Electrical Engineer. HDR provided engineering services including preliminary design, final design, bidding, and construction phase services including inspection of coatings and repairs. Work included assessment of structural and mechanical components of the 1MG steel reservoir and reservoir site. The scope of work was amended to include installation of a permanent generator and improvements to the Wilder Pump Station building for the purpose of fire hardening. Justin led the electrical and I&C design for new and replacement electrical conduit and a new permanent emergency generator, sized to power the reservoir site and associated pump station during an emergency outage.

Irvine Ranch Water District, Michelson Water Recycling Plant Tertiary Filters Improvements, Irvine, CA

Lead Electrical Engineer. Justin and the HDR team are providing preliminary design, final design, and construction phase services for improvements to the tertiary filters, backwash supply system,

air scour blower, and relevant electrical and instrumentation systems at the Michelson Water Reclamation Plant to improve treatment efficiency and system reliability.

Long Beach Utilities Department (LBUD), Alamitos Tank Nos. 19 and 20 Conversion Project, Long Beach, CA

Electrical Project Engineer. Justin and the HDR team converted two of LBUD's potable water tanks, Alamitos Tanks Nos. 19 and 20, to recycled water tanks to provide additional storage for a growing demand for recycled water in the City of Long Beach. The project comprised of rehabilitating and converting these tanks for use with LBUD's recycled water system.

City of Ventura, Aeration Blower Replacement, Ventura, CA

Lead Electrical Engineer. Justin served as lead electrical engineer for a project that involved demolition of the existing aeration blowers and building, construction of a new blower building and electrical room, installation of more efficient high-speed turbo blowers that utilize a lower-voltage (480V) power supply.

Santa Margarita Water District (SMWD), Oso Creek Water Reclamation Plant (OCWRP), Design and Construction Services, Rancho Santa Margarita, CA

Lead Electrical Engineer. Justin is serving as lead electrical engineer for the design of new treatment plant to replace the OCWRP. The design is partially completed by SMWD staff, and HDR will take over the design and complete it. The design will be done in several packages and issued for construction in a logical sequence. The design includes a new headworks and influent lift station, fine screening, MBR, chlorine contact basin, and effluent pump station.

City of North Platte and Sustainable Beef, North Platte Industrial Wastewater Treatment Plant, North Platte, NE

Lead Electrical Engineer. Justin served as the lead electrical engineer for the design and construction phase of a new 2mgd wastewater treatment plant to treat industrial waste from the nearby Sustainable Beef meat processing facility. The plant consists of a pretreatment lift station, anaerobic lagoons, biogas building, pre-anoxic basins, aeration basins, mixed liquor recycle pumping, Micro C chemical feed, sodium hydroxide chemical feed, final clarifiers, RAS pumps, scum/WAS pumps, and dewatering.

Shared Resources LLP, Water Treatment Plant, Moody County, SD

Lead Electrical Engineer. Justin and the HDR team completed the process, mechanical, electrical, instrumentation/control, and fire/life/safety portions of the design and are providing construction phase services. Shared Resources LLP was created by the Minnehaha Community Water Corporation and the Big Sioux Community Water System to ensure each entity has additional drinking water for the future. Both systems had existing water treatment facilities and distribution networks to provide safe, reliable drinking water, but experienced significant growth and needed additional source water and treatment facilities. The electrical design incorporated utility primary power via 2500kVA transformer to the facility and two 2,000KW 2500kVA standby generators with automatic throw-over controller and relays.

Orange County Sanitation District (OC San), FE20-02 Digester Mechanical Replacements, Fountain Valley, CA

Lead Electrical Engineer. Justin and the HDR team are providing professional engineering services for replacement of various mechanical equipment and piping for Digesters C, D, F and G. The rehabilitation includes high-rate mixing pumps (4 each), sludge transfer pumps (2 each), hot water pumps (4 each) and heat exchanger and associated piping.

City of San Diego Public Utilities Department, MetroBiosolids Center Gas Detection, San Diego, CA

Lead Electrical Engineer. Justin and the HDR project team are providing professional engineering design and construction services for the replacement of over 200 units of the existing Gas Detection System at MetroBiosolids Center. Much of the gas detection system are nonfunctional and poses a safety concern for the staff. The facility is fitted with over 200 gas monitors. The gas detection system monitors for Ammonia, Carbon Monoxide, Hydrogen Sulfide and Methane gas. The existing gas monitors were manufactured by Mine Safety Appliances and were installed over 20 years ago.

Port of Long Beach, Pier B On-Dock Rail Support Facility Program - LA-04 Stormwater Pump Station, Long Beach, CA

Lead Electrical Engineer. Justin and the HDR project team are providing final engineering design services for the Pier B On-Dock Rail Support Facility. Work included electrical, instrumentation, mechanical, civil, structural and architectural disciplines to design the construction of a new stormwater pump station. This included new electrical service, standby generator, electrical equipment, instrumentation and controls equipment, four stormwater pumps, piping, mechanical equipment, and HVAC equipment.

Long Beach Utilities Department, S-8 Sewer Lift Station (SLS) Rehabilitation, Long Beach, CA

Lead Electrical Engineer. Justin and the HDR team are providing design services to rehabilitate the aging S-8 SLS. By identifying upgrades and bringing the SLS into code compliance, the project team hopes to serve LBUD far into the future.

Long Beach Utilities Department, S-25 Lift Station, Long Beach, CA

Electrical Project Engineer. Justin served as electrical project engineer on a project where HDR was a subconsultant to DRP Engineering, Inc. for preliminary design and engineering services during construction support for the S-25 lift station.



LICENSING

Professional Land Surveyor No.
7807, California

EDUCATION

B.S. Surveying Engineering,
California State University Fresno,
1999

PROFESSIONAL AFFILIATIONS

Past Officer, California Land
Surveyors Association, State &
Channel Islands Chapter

Past President, ACEC, Channel
Coast Chapter

Past Committee Member,
Channel Islands CLSA Chapter -
Joint Professional Practices
Committee

Member, International Right of
Way Association (IRWA)

BACKGROUND

James Fallon has nearly 24 years of experience on a wide variety of land surveying and geomatics projects. He has been responsible for the direct management and production of survey tasks in support of public works and private land development projects, both in the field and in the office. Work performed includes topographic mapping, monument preservation, public agency map and document review, geodetic control networks, boundary surveys, easement and legal description preparation, subdivision mapping, lot line adjustments, ALTA land title surveys, condominium plans, right of way acquisition surveys, construction staking, and data acquisition for Geographic Information Systems (GIS). His work includes numerous public infrastructure projects, encompassing many miles of corridor surveys for design improvements in Ventura, Los Angeles and Santa Barbara Counties.

24 years of experience with
Base Topographic Mapping,
Geodetic Control Surveys and
Geographic Information Systems

Mr. Fallon has extensive experience with static GPS, real time kinematic GPS and GPS control networks utilizing Continuously Operating Reference Stations (CORS) through both the National Geodetic Survey (NGS) and California Spatial Reference Center (CSRC). Mr. Fallon is thoroughly familiar with AutoCAD Civil 3D, the Microsoft Office Suite, Trimble GPS processing software, ESRI ArcGIS and major surveying data collection and network adjustment software packages.

EXPERIENCE

PUBLIC AGENCIES

- **Casitas Municipal Water District, Ojai, CA**
- **California American Water, Southern California**
- **United Water Conservation District, On-call Agreement, Ventura County, CA**
- **Calleguas Municipal Water District, Ventura County, CA**
- **Santa Clarita Valley Water Agency, On-Call Agreement, Santa Clarita, CA**
- **Ventura Regional Sanitation District, Santa Paula, CA**
- **Santa Clarita Valley Water Agency, Santa Clarita, CA**
- **City of Ventura, On-Call Agreement, Ventura, CA**
- **City of Camarillo, On-Call Agreement, Camarillo, CA**
- **City of Port Hueneme, Port Hueneme, CA**
- **City of Oxnard, On-Call Agreement, Oxnard, CA**
- **Camarillo & Oxnard Airports, Ventura County, CA**
- **City of Santa Barbara, On-Call Agreement, Santa Barbara, CA**

RELEVANT PROJECTS

North Pleasant Valley Desalter, Camarillo, CA

Project surveyor and task manager for the base mapping in support of design efforts on a new desalter facility and related waterlines. The project corridor covered approximately 7,500 linear feet and a 4 acre plant site. Mapping was performed by conventional ground methods, ground based Lidar and included record right of way and utility research and compilation.

Santa Felicia Dam Monitoring, Piru, CA

Project surveyor and task manager for high precision monitoring surveying services as part of the biennial structural monitoring of the Santa Felicia Dam since 2005. The work includes high order leveling across miles of ground from and to the monitoring benchmark, across the dam crest and to other historical monitor points. Extensive horizontal and alignment measurements are made along the crest, and all the data are presented in historical tables for District review and use.

Lynnwood Drive Sewerline Replacement , Camarillo, CA

Project surveyor and task manager for the base mapping for a replacment Camrosa Water District sewer line in Camarillo. Mapping was performed by conventional ground methods, ground based Lidar and included record utility research and right of way compilation.

Arbolada Pump Station Upgrade, Ojai, CA

Project surveyor and task manager for the base mapping in support of design efforts on an upgrade to existing facilities within the Casitas Municipal Water District system. The project corridor covered approximately 3,500 linear feet and a 1 acre plant site. Mapping was performed by conventional ground methods, ground based Lidar and included record right of way and utility research and compilation.

Ojai Waterline Improvments, Ojai, CA

Project surveyor and task manager for the base mapping in support of design efforts on an upgrade to existing facilities within the Casitas Municipal Water District system. The project corridors covered approximately 5,300 linear feet over 3 project areas. Mapping was performed by conventional ground methods, ground based Lidar and included record right of way and utility research and compilation.

Casitas Municipal Water District Pipeline Replacements, Ojai, CA

Project surveyor and task manager for the base mapping in support of design efforts on several pipeline replacment projects. As of 2019, the project corridors covered approximately 10,000 linear feet and multiple reservoir sites. Mapping was performed by conventional ground methods, ground based Lidar and included record right of way and utility research and compilation.

Portrero Road Recycled Waterline Project, Thousand Oaks, CA

Project surveyor and task manager for the base mapping in support of design efforts on a new recycled waterline and the extension of an existing Triunfo Santitation District waterline. The project corridor covered approximately 4,000 linear fee. Mapping was performed by conventional ground methods, ground based Lidar and included record right of way and utility research and compilation.

California American Water Mission View Blend Station, Temple City, CA

Project surveyor and task manager for the base mapping for a new 5,400-foot waterline connecting existing CAW pump stations. Mapping was performed aerial mapping, supplemented by ground surveys and included record utility research and compilation.

Middlebank Drive Waterline Project- Newhall Water Company, CA

Project surveyor for the base mapping and construction of a replacement waterline within a residential neighborhood. Survey included ground based topographic mapping, utility research and providing construction staking for the installation of the new line.



625 E. Santa Clara St., Suite 100
Ventura, CA 93001
805.585.4500

hdrinc.com

We practice increased use of sustainable materials and reduction of material use.

© 2026 HDR, Inc., all rights reserved.

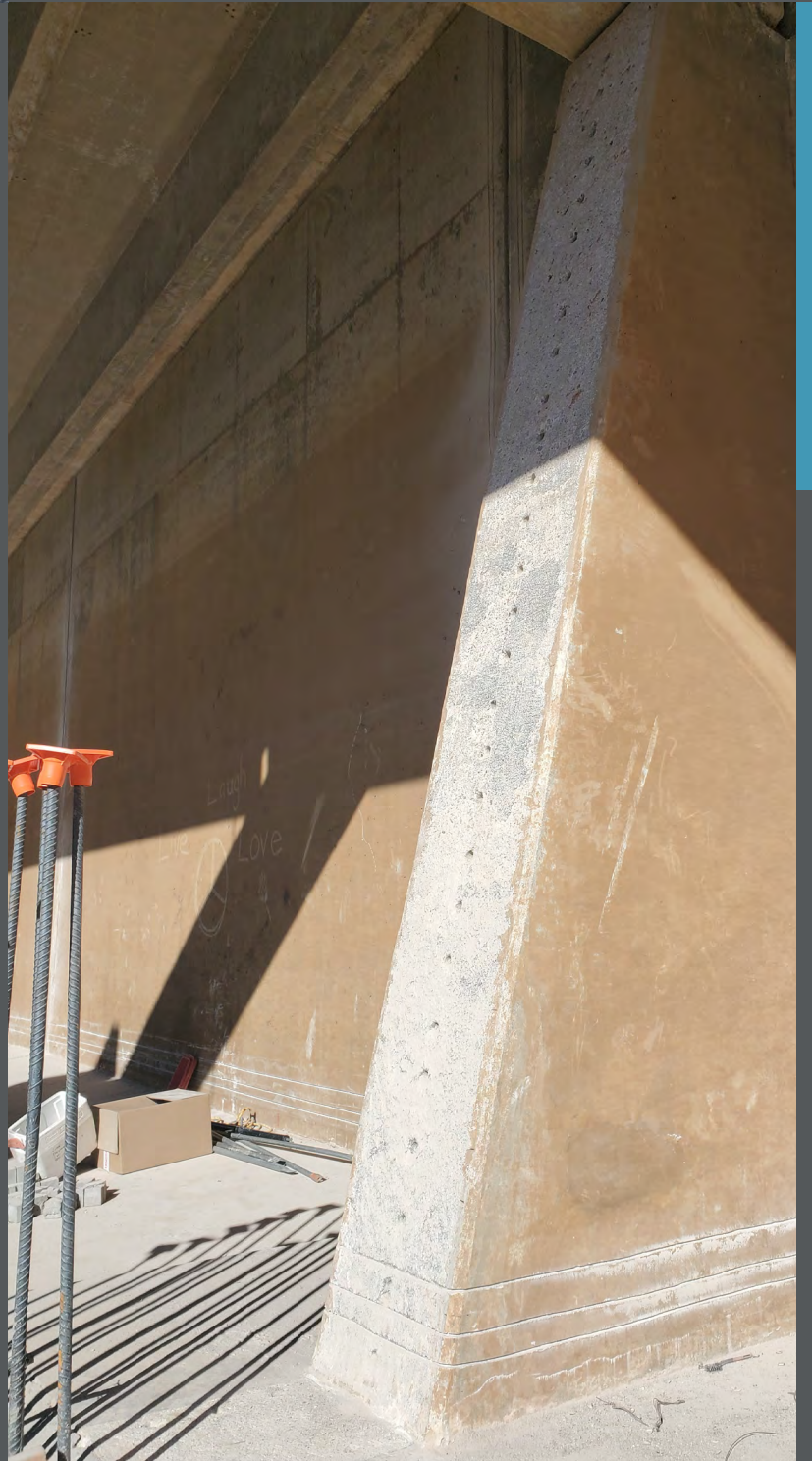



COST PROPOSAL FOR

EQUESTRIAN TANK REHABILITATION PROJECT DESIGN

2026-RFP-041



March 18,
2026



March 18, 2026

Las Virgenes Municipal Water District
4232 Las Virgenes Rd.
Calabasas, CA 91302
Ph: (310) 660-6207

Submitted via: OpenGov portal

Subject: HDR Proposal for the Equestrian Tank Rehabilitation Project Design, 2026-RFP-041

Dear Selection Committee,

HDR Engineering, Inc. (HDR) has developed a cost proposal for the Equestrian Tank Rehabilitation Project Design being requested by the Las Virgenes Municipal Water District (the District). The services associated with the work are described in our technical proposal response and are further detailed in our scope of work. This cost proposal includes a breakdown of our proposed fee.

We are excited by the opportunity to work with the District again by performing the design for the Equestrian Tank Rehabilitation Project. Should you have any questions or comments please do not hesitate to contact us.

Sincerely,

HDR Engineering, Inc.

Anna Lantin, PE
Sr. Vice President

Dan Ellison, PE, SE
Project Manager

COST PROPOSAL

We are committed to complete the scope of work for each task as described in the RFP. Should Las Virgenes MWD select the HDR team, we welcome the opportunity to sit down with you to discuss the scope and fee and further align assumptions as necessary.

Las Virgenes Municipal Water District Equestrian Tank Rehabilitation Design Estimated Level of Effort and Fee

TASKS		LEVEL OF EFFORT															FEE						
No.	Description	Principal	Project Manager	Quality Reviewer	Project Engineer	Senior Structural Engineer	Structural Engineer	Senior Civil Engineer	Senior Corrosion Engineer	Corrosion Engineer	Electrical and I&C Engineer	Safety Manager	CADD Tech	Coating Inspector-PW	Accountant	Project Coordinator	Total Labor	Labor	Raw Subs	Markup on Subs	Subs	Direct Costs	Total
		Client Billing Rates																					
		\$375	\$375	\$330	\$190	\$250	\$180	\$280	\$285	\$180	\$225	\$250	\$175	\$210	\$160	\$150	\$227						
1	Phase 1 - Project Initiation, data review, and site assessment																						
1.1	Records review		3	3	3						3						12	\$3,360	\$0	\$0	\$0	\$67	\$3,427
1.2	Kickoff meeting (hybrid--inperson and virtual)	2	3		4												9	\$2,635	\$0	\$0	\$0	\$53	\$2,688
1.3	Site visit with client (same day as kickoff meeting)		4		4												8	\$2,260	\$0	\$0	\$0	\$45	\$2,305
1.3.1	In-tank inspections -- OPTIONAL -- see below for hours and fee																0	\$0	\$0	\$0	\$0	\$0	\$0
1.4	Site survey -- OPTIONAL --see below for fee																0	\$0	\$0	\$0	\$0	\$0	\$0
1.4.1	Analysis of main girder -- OPTIONAL -- see below for hours and fee																0	\$0	\$0	\$0	\$0	\$0	\$0
1.5	Project Administration		6		14										20	20	60	\$11,110	\$0	\$0	\$0	\$222	\$11,332
btotals 1	Phase 1 - Project Initiation, data review, and site assessment	2	16	3	25	0	0	0	0	0	3	0	0	0	20	20	89	\$19,365	\$0	\$0	\$0	\$387	\$19,752
2	Preliminary and Final Design																						
2.1	Preliminary Engineering TM - Draft	3	22	5													30	\$11,025	\$0	\$0	\$0	\$221	\$11,246
2.1.1	Review Meeting (virtual)		4	5													9	\$3,150	\$0	\$0	\$0	\$63	\$3,213
2.1.1	Preliminary Engineering TM - Final		5														5	\$1,875	\$0	\$0	\$0	\$38	\$1,913
2.2	Bid Documents (12 sheets, specs, OPCC)	6	20	17	88	9	27	44			40		198				449	\$95,160	\$0	\$0	\$0	\$1,903	\$97,063
2.2.1	60% submittal and review meeting		4		18			4					14				40	\$8,490	\$0	\$0	\$0	\$170	\$8,660
2.2.2	90% submittal and review meeting		4		18			4					8				34	\$7,440	\$0	\$0	\$0	\$149	\$7,589
2.2.3	100% submittal		3		8			3					9				23	\$5,060	\$0	\$0	\$0	\$101	\$5,161
	Subtotal 2 Preliminary and Final Design	9	62	27	132	9	27	55	0	0	40	0	229	0	0	0	590	\$132,200	\$0	\$0	\$0	\$2,645	\$134,845
3	Bid and Construction-Phase Services																						
3.1	PreBid Meeting		2		3												5	\$1,320	\$0	\$0	\$0	\$26	\$1,346
3.2	Addenda (up to 2)		6		10												16	\$4,150	\$0	\$0	\$0	\$83	\$4,233
3.3	PreConstruction Meeting	2	2		3												7	\$2,070	\$0	\$0	\$0	\$41	\$2,111
3.4	Tech Document Reviews (RFIs -- up to 5 & Submittals -- up to 25)		14		66			23									103	\$24,230	\$0	\$0	\$0	\$485	\$24,715
3.5	Construction Progress Mtgs (2 at site, 3 virtual)	2	10		10			3									25	\$7,240	\$0	\$0	\$0	\$145	\$7,385
3.6	Final Job Walk		2		4			3									9	\$2,350	\$0	\$0	\$0	\$47	\$2,397
3.7	Record Drawings				6							20					26	\$4,640	\$0	\$0	\$0	\$93	\$4,733
3.8	Site Inspections -- OPTIONAL -- see below for hours and fee																0	\$0	\$0	\$0	\$0	\$0	\$0
	Subtotal 3 Bid and Construction-Phase Services	4	36	0	102	0	0	29	0	0	0	0	20	0	0	0	191	\$46,000	\$0	\$0	\$0	\$920	\$46,920
TOTAL, hours		15	114	30	259	9	27	84	0	0	43	0	249	0	20	22	872						
TOTAL, dollars																		\$197,865	\$0	\$0	\$0	\$3,958	\$201,823
OPTIONAL TASKS		OPTIONAL LEVEL OF EFFORT															OPTIONAL FEE						
A	Task Name																						
1.3.1	In-tank inspections -- PLANNING & DOCUMENTATION		2		2				6	12	4			1	1		28	\$6,270	\$0	\$0	\$0	\$125	\$6,395
1.3.2	In-tank inspections -- FLOAT INSPECTION		4		4					10	10			1	1		30	\$6,680	\$0	\$0	\$0	\$180	\$6,860
1.3.3	In-tank inspections -- DRY INSPECTION + LAB TESTING		4		4					20				1	1		30	\$6,230	\$4,000	\$0	\$4,000	\$523	\$10,753
1.4	Site survey -- TOPOGRAPHIC BASE MAP		2		2			4					4	4			20	\$4,730	\$7,500	\$750	\$8,250	\$95	\$13,075
1.4.1	Analysis of main girder -- IF SETTLEMENT IS FOUND		2	4	1	8	32							1	1		49	\$10,390	\$0	\$0	\$0	\$208	\$10,598
3.8	Site Inspections -- AMPP LEVEL 3 INSPECTOR - 5 WEEKS		2		2				8				200		2		215	\$38,940	\$0	\$0	\$0	\$8,100	\$47,040
	Subtotal A Task Name	0	16	4	15	8	32	4	14	42	14	4	200	9	10	0	372	\$73,240	\$11,500	\$750	\$12,250	\$9,231	\$94,721
TOTAL for Optional Tasks, hours		0	16	4	15	8	32	4	14	42	14	4	200	9	10	0	372						
TOTAL for Optional Tasks, dollars																		\$73,240	\$11,500	\$750	\$12,250	\$9,231	\$94,721
TOTAL for all Tasks (including Optional Tasks), hours		15	130	34	274	17	59	88	14	42	57	4	449	9	30	22	1,244						
TOTAL for all Tasks (including Optional Tasks), dollars																		\$271,105	\$11,500	\$750	\$12,250	\$13,189	\$296,544



625 E. Santa Clara St., Suite 100
Ventura, CA 93001
805.585.4500

hdrinc.com

We practice increased use of sustainable materials and reduction of material use.

© 2026 HDR, Inc., all rights reserved.

